

chlodi::lyser

chlodi::lyser monitors chlorine dioxide (CLD)

- s::can plug & measure
- measuring principle: amperometric (membrane covered)
- ideal for all kinds of water treatment
- long term stable and lowest maintenance in operation
- replacement of membrane only once a year
- readings stable even at high fluctuations of pH, temperature and flow
- strong surfactants are tolerated
- factory precalibrated
- mounting and measurement in a flow cell
- operation via s::can terminals & s::can software
- additionally also measures temperature

recommended accessories

part number	article name
D-330-xxx	con::cube V3
D-320-xxx	con::lyte
C-1-010-sensor	1 m connection cable for s::can physical and ISE probes
E-528-1/2-KIT	Chlorine Dioxide electrolyte and membrane cap (spare parts)
F-45-four	flow cell for four s::can physical probes
F-45-sensor	flow cell for s::can sensor
S-11-xx-moni	moni::tool Software

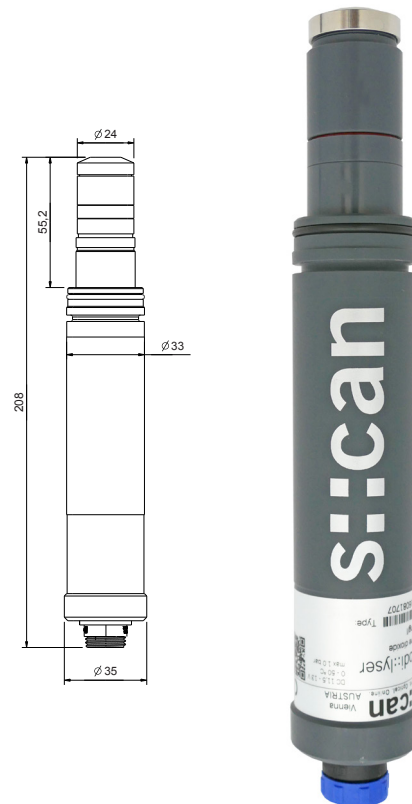

technical specification

measuring principle	amperometric	housing material	PVC
measuring principle detail	potentiostatic 2-electrode system, membrane covered		Stainless steel 1.4571
resolution	0.001 mg/l for 0 - 2 mg/l 0.01 mg/l for 0 - 20 mg/l	weight (min.)	150 g
automatic compensation instrument	temperature	dimensions (Ø x l)	35 x 208 mm
response time (T90)	1 min.	operating temperature	0 ... 50 °C
integration via	con::cube con::lyte con::nect	operating pressure	0 ... 1 bar
power supply	9 ... 30 VDC	installation / mounting	flow cell
power consumption (typical)	0.5 W	process connection	quick connect
power consumption (max.)	0.6 W	recomended flow	15 ... 30 l/h (in s::can flow cell)
interface to s::can terminals	sys plug (IP67), RS485	pH range	1 ... 12
		storage temperature	0 ... 45 °C
		conformity - EMC	EN 61326-1
		protection class (-000)	IP67

measuring range

		parameter		
		chlorine dioxide [mg/l]	temperature [°C]	part number
chlodi::lyser	min.	0	0	E-528-1-000
	max.	2	50	
chlodi::lyser	min.	0	0	E-528-2-000
	max.	20	50	