

hyper::lyser

hyper::lyser monitors hydrogen peroxide (H₂O₂)

- s::can plug & measure
- measuring principle: amperometric (membrane covered)
- ideal for all kinds of water treatment
- long term stable and lowest maintenance in operation
- replacement of membrane only once a year
- readings stable even at high fluctuations of pH, temperature and flow
- strong surfactants are tolerated
- factory precalibrated
- mounting and measurement in a flow cell
- operation via s::can terminals & s::can software
- additionally also measures temperature

recommended accessories

part number	article name
C-1-010-sensor	1 m connection cable for s::can physical and ISE probes
D-315-xxx	con::cube
E-509-1/2-El	Hydrogen Peroxide elektrolyte (spare part)
E-509-1/2-SET	Hydrogen Peroxide membrane cap (spare part)
D-319-xxx	con::lyte
F-45-four	flow cell for four s::can physical probes
F-46-four-iscan	i::scan flow cell for up to 3 additional s::can probes
F-45-sensor	flow cell for s::can sensor
S-11-xx-moni	moni::tool Software

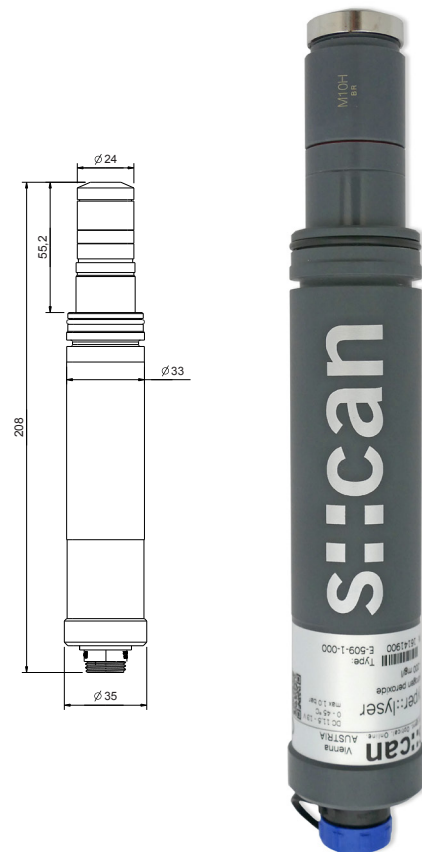

technical specification

measuring principle	amperometric	housing material	PVC
measuring principle detail	potentiostatic 2-electrode system, membrane covered		Stainless steel 1.4571
resolution	0.1 mg/l	weight (min.)	150 g
automatic compensation instrument	temperature	dimensions (Ø x l)	35 x 208 mm
response time	5 ... 10 min.	operating temperature	0 ... 45 °C
integration via	con::cube con::lyte con::nect	storage temperature	0 ... 40 °C
power supply	9 ... 30 VDC	operating pressure	0 ... 1 bar
power consumption (typical)	0.5 W	installation / mounting	flow cell
power consumption (max.)	0.6 W	process connection	quick connect
interface to s::can terminals	sys plug (IP67), RS485	recommended flow	15 ... 30 l/h
		pH range	2 ... 11
		conformity - EMC	EN 61326-1
		protection class (-000)	IP67

drinking water

		concentration ranges and sensor/probe type for this application	
		hydrogen peroxide [mg/l]	part number
hyper::lyser	min.	0	E-509-1-000
	max.	200	