



Oxygen Transmitter

Model 1732 Technical Manual



February 2022

TABLE OF CONTENTS

1. IMPORTANT NOTICES	7
1.1 CAUTIONS	7
1.2 WARNING SYMBOLS	8
2. INTRODUCTION	9
2.1 THE 1732 TRANSMITTER	9
2.2 SERIES 1230 OXYGEN PROBES & SENSORS	10
3. DEVICE SPECIFICATIONS	11
3.1 HARDWARE SPECIFICATIONS	11
3.1.1 Transmitter Specifications	11
3.1.2 Series 1230 Probes Specifications	12
3.1.3 Model 1234 Sampling Sensor Specifications	13
3.1.4 Probe Ordering Information	13
3.2 OPERATIONAL SPECIFICATIONS	14
4. INSTALLATION AND COMMISSIONING	15
4.1 MOUNTING THE TRANSMITTER	15
4.2 INSTALLING A 1231 OXYGEN PROBE	15
4.3 INSTALLING A 1234 OXYGEN SENSOR	17
4.4 INSTALLING THE AUXILIARY THERMOCOUPLE	17
4.5A SHIELD CONNECTIONS	18
4.5B EARTH CONNECTION (PE)	18
4.6 ELECTRICAL CONNECTIONS	19
4.7 HEATER INTERLOCK RELAYS	21
4.8 CONNECTING AN OXYGEN PROBE CABLE	22
4.9 CONNECTING A 1234 SENSOR CABLE	23
4.10 CONNECTING THE AUXILIARY THERMOCOUPLE (OPTIONAL)	23
4.11 CONNECTING THE OUTPUT CHANNELS	23
4.12 CONNECTING THE ALARMS	23
4.13 CONNECTING THE AUTOMATIC PURGE AND CALIBRATION CHECK SYSTEM	24
4.14 CONNECTING REFERENCE AIR	25
4.15 CONNECTING THE TRANSMITTER TO A MODBUS™ NETWORK	25
4.16 CONNECTING POWER	25
4.17 COMMISSIONING - RUN MODE	26
4.18 PROBE OR SENSOR CALIBRATION	26
4.19 FILTER PURGING	26
4.20 CALIBRATION GAS CHECK	26
4.21 DUST IN THE FLUE GAS	27
4.22 STRATIFICATION	27
4.23 CONNECTING A PRESSURE TRANSDUCER	27
5. DISPLAY AND KEYPAD	29
5.1 RUN MODE DISPLAY	29
5.2 OXYGEN DISPLAY UNITS	30
5.3 KEYPAD	30
5.3.1 Keypad in Run Mode	31
5.3.2 Keypad in the Setup / Commissioning / Calibration Menu	31
6. SETUP MENU	33
6.1 FUNCTION SUMMARY TABLE	33
6.2 SETUP MENU DISPLAY	33
6.3 CHANGING MENU OPTIONS	33
6.4 SETUP MENU FUNCTIONS	34

6.4.1 Probe 1 Offset	34
6.4.2 Lower Line Items	34
6.4.3 Oxygen Display Units	35
6.4.4 Damping Factor	35
6.4.5 Process Alarms	35
7. COMMISSIONING MENU	37
7.1 FUNCTION SUMMARY TABLE	37
7.2 COMMISSIONING MENU FUNCTIONS	39
7.2.1 Internal Date / Time	39
7.2.2 Service Date	39
7.2.3 Number of Probes	39
7.2.4 Probe 1 & 2 Type	39
7.2.5 Probe 1 & 2 Thermocouple Type	39
7.2.6 Auxiliary Thermocouple Type	39
7.2.7 Transmitter Output Channel 1 & 2	40
7.2.8 Flue Pressure Units	40
7.2.9 Flue Pressure Input Units and Value	40
7.2.10 Temperature Units	41
7.2.11 Calibration Freezes Outputs	41
7.2.12 Solenoid 1 & 2 Operation	41
7.2.13 Solenoid 1 & 2 Automatic / Manual	41
7.2.14 Solenoid 1 & 2 Start Time	41
7.2.15 Solenoid 1 & 2 Frequency	42
7.2.16 Solenoid 1 & 2 Duration	42
7.2.17 Solenoid 1 & 2 Post Freeze / Sample Pre-Purge	42
7.2.18 Oxygen Content Calibration Gas 1 & 2	42
7.2.19 Maximum Calibration Gas 1 & 2 Positive / Negative Error	42
7.2.20 Process Alarms	42
7.2.21 Alarm Relay 1, 2 and 3 Function	43
7.2.22 Common Alarm Relay Function	43
7.2.23 Accepted Alarm Relay Hold	43
7.2.24 Probe Impedance Test Options	44
7.2.25 Selecting the Correct Fuel	44
7.2.26 Reference Air Pump Options	44
7.2.27 Communications Port Options	45
7.2.28 Alarm Log Clearing	45
8. CALIBRATION MENU	47
8.1 FUNCTION SUMMARY TABLE	47
8.2 CALIBRATION MENU FUNCTIONS	48
8.2.1 Reference Voltages	48
8.2.2 Output Channel 1 and 2 Calibration	48
8.2.3 Ambient Temperature Calibration	48
8.2.4 Low Oxygen Calibration	48
8.2.5 Reference Air Probe 1 and Probe 2	48
8.2.6 Transmitter Output Scale	48
8.2.7 Transmitter Output Limiting	49
8.2.8 Mains Voltage Detection	49
8.2.9 Heater SSR Fault Correction	49
8.2.10 SSR Fail Protection	49
8.2.11 Burner Temp Override	50
8.2.12 Ref Pump Cycling	50
8.2.13 Dry Reference Air	50
9. ALARMS	51
9.1 CHECKING AND ACCEPTING AN ALARM	52
9.1.1 Current Alarms	52
9.1.2 Alarm Log	52
9.2 HARDWARE ALARMS	53
9.3 PROCESS RELATED ALARMS	55
9.4 STATUS ALARMS	55
9.5 ALARM RELAY OPTIONS	56

10. INSTRUMENT CALIBRATION	57
10.1 CALIBRATION SUMMARY.....	57
10.1.1 Calibration of the Inputs	57
10.1.2 Calibration of the Outputs.....	57
10.1.3 Probe Calibration.....	58
10.2 COLD START	58
10.2.1 Forcing a Cold Start	58
10.2.2 Resetting the Calibration Factors.....	58
11. GAS CALIBRATION CHECK AND PURGE.....	59
11.1 PROBE PURGE	59
11.2 CALIBRATION GAS CHECK.....	59
11.3 SOLENOID CONTROL OF OXYGEN SAMPLING.....	60
12. SOFTWARE UPGRADES.....	61
13. TROUBLESHOOTING	63
13.1 FIRST APPROACH	63
13.2 DETAILED FAULT ANALYSIS	63
14. MAINTENANCE	65
14.1 TRANSMITTER MAINTENANCE	65
14.2 CLEANING	65
14.3 REPLACEMENT PARTS.....	65
15. INDEX.....	66
APPENDIX 1, CONSTITUENT VALUES FOR VARIOUS FUELS.....	67
APPENDIX 2, PROBE EMF TABLES	68
APPENDIX 3, % OXYGEN SCALE TO LOGARITHMIC.....	70
APPENDIX 4, MODBUS™	71
END OF LIFE TREATMENT AND FINAL DISPOSAL	74
DECLARATION OF CONFORMITY	75

© Copyright NOVATECH CONTROLS PTY LTD — 2022

This manual describes the transmitter firmware version 1.55, 26 July 2021

Neither the whole nor any part of the information contained in, or the product described in, this manual may be adapted or reproduced in any material form except with the prior written approval of Novatech Controls Pty Ltd (Novatech).

The product described in this manual and products for use with it are subject to continuous developments and improvement. All information of a technical nature and particulars of the product and its use (including the information in this manual) are given by Novatech in good faith. However, it is acknowledged that there may be errors or omissions in this manual. A list of details of any amendments or revisions to this manual can be obtained upon request from Novatech Controls Technical Enquiries. Novatech Controls welcome comments and suggestions relating to the product and this manual.

All correspondence should be addressed to: -

Technical Enquiries
Novatech Controls Pty Ltd
309 Reserve Road,
Cheltenham
Victoria 3192
Australia

Tel: +61 3 9585 2833
Fax: +61 3 9585 2844
Email: info@novatech.com.au
Website: <https://www.novatech.com.au/>

Novatech Controls or their authorised dealers should carry out all maintenance and service on the product. Novatech Controls can accept no liability whatsoever for any loss or damage caused by service or maintenance by unauthorised personnel. This manual is intended only to assist the reader in the use of the product, and therefore Novatech Controls shall not be liable for any loss or damage whatsoever arising from the use of any information or particulars in, or any error or omission in, this manual, or any incorrect use of the product.

Important Notice Regarding 1231 Probe Option - FIL-3

WARNING: The only identifiable standard for flame arresters for general use is British Standard BS EN 12874:2001. British Standard BS EN 12874:2001 refers to an operating environment up to 150 Degrees Centigrade.

The FIL-3 device optionally fitted to 1231 Heated Zirconia Probes (the "Probes" or "Probe") operate in an environment considerably greater than 150 Degrees Centigrade.

Therefore, we know of no Australian, British, European or USA standard applicable to flame arresters or their testing above 150 degrees Centigrade. Consequently, the FIL-3 device cannot be certified as a safety device.

The probe is only one of several potential sources of ignition. Extreme care is required when using the probes during the start-up processes of a combustion appliance.

The Novatech Burner Interlock Relay facility, which is a standard part of the Novatech transmitter, is designed to be wired to the main safety shut-off fuel valves in a way that can shutdown the probe heater when the fuel valves are closed.

The risk of ignition of flammable gas mixture at the hot end of the Probe can only be minimised by correct use, maintenance and operation of the FIL-3 device. The user of the FIL-3 device is responsible for verification and maintenance and correct use and operation of the FIL-3 device.

THE USER AGREES THAT IT USES THE PROBE AND THE FIL-3 DEVICE AT ITS SOLE RISK. NOVATECH CONTROLS PTY LTD, TO THE FULL EXTENT PERMITTED BY LAW, GIVES NO WARRANTIES OR ASSURANCES AND EXCLUDES ALL LIABILITY (INCLUDING LIABILITY FOR NEGLIGENCE) IN RELATION TO THE PROBE AND THE FIL-3 DEVICE.

The user must ensure that it correctly follows all instructions in relation to the Probe and FIL-3 device, correctly understands the specifications of the Probe and FIL-3 device and ensures that the Probe and FIL-3 device are regularly inspected and maintained.

FIL-3 equipped Probes should be inspected at least once a year for corrosion and more frequently if there is any reason to suspect that corrosion may have occurred.

This page has been intentionally left blank.

1. IMPORTANT NOTICES

This manual is a complete version of the 1732 Dual Probe Oxygen Transmitter product manual. It is intended to be used by technical personal that are qualified to install, commission, service and calibrate electronic industrial control equipment. A separate Operators Manual is also supplied with the transmitter intended to be used as a reference for basic operation once the device is commissioned. Both manuals are supplied with each transmitter and are also available to download at the Novatech Controls website.

<https://www.novatech.com.au/products/1732/>

Please read the safety information below before connecting power to the transmitter.

1.1 Cautions

CAUTION 1

The probe heater is supplied with mains voltage. This supply has electrical shock danger to maintenance personnel. Always isolate the transmitter before working with the probe.
The EARTH wires (green/yellow) from a heated probe must ALWAYS be connected to earth.

CAUTION 2

Combustion or atmosphere control systems can be dangerous. Burners must be mechanically set up so that in the case of equipment failure, the system cannot generate explosive atmospheres. This danger is normally avoided with flue gas trim systems by adjustment so that in the case of failure the appliance will not generate CO in excess of 400ppm in the flue. The CO level in the flue should be measured with a separate CO instrument, normally an infrared or fuel cell type.

CAUTION 3

The oxygen probe is heated to over 700°C (1300°F) and is a source of ignition. Since raw fuel leaks can occur during burner shutdown, the transmitter has an interlocking relay that removes power from the probe heater when the main fuel shut-off valve power is off. If this configuration does not suit or if it is possible for raw fuel to come into contact with a hot oxygen probe then the Model 1732 transmitter with a heated probe will not be safe in your application.
An unheated probe can be utilised in such applications, however the oxygen readings are valid only above 650°C (1200°F).

CAUTION 4

The reducing oxygen signal from the transmitter and the associated alarm relay can be used as an explosive warning or trip. This measurement assumes complete combustion. If incomplete combustion is possible then this signal will read less reducing and should not be used as an alarm or trip. A true excess combustibles analyser, normally incorporating a catalyst or thermal conductivity bridge, would be more appropriate where incomplete combustion is possible.
Also read the probe electrical shock caution in the probe heater interlock caution in chapter 4.7

CAUTION 5

FIL-3 filter. If the optional FIL-3 has been fitted to the 1231 probe in this installation, please read the Important Notice regarding probe option FIL-3 on the previous page

CAUTION 6

The heater is supplied from the mains power directly, and the temperature is controlled at 720°C (1330°F). The outside of the process end of the probe can get to temperatures that are dangerous to touch. Wear insulating gloves when handling a probe that has been on.

CAUTION 7

Please note that if this equipment is not installed and used in the manner described in this manual then the safety protection provided by the equipment may be impaired.

1.2 Warning Symbols



Danger, high voltage. Risk of electrical shock.



Caution hot surface.



Caution, risk of danger. See additional information in the manual.

2.1 The 1732 Transmitter

The Novatech 1732 Oxygen Transmitter is designed to measure oxygen concentration in a range of combustion applications such as power stations and industrial boilers. The measurement is used to control the air / fuel ratio in the burner to maintain efficiency and safe operation conditions.

The transmitter is designed to be used along with the range of Novatech heated and unheated oxygen probes. These probes use a zirconia sensor operating in environments up to 1400° (2010°F). The 1231 oxygen probe has an integrated heater, while the 1232 probe uses the process heat to heat the sensor. There is a unique cable connection between the 1732 transmitter and the 1231/1232/1234 probe.

The 1732 Oxygen Transmitter builds on the previous generation model 1632 transmitter. It adds many hardware and software improvements, such as a larger display capable of showing more detailed process information and a more intuitive menu system to aid in configuration. The device is built using an improved microprocessor, capable of handling the complex equations used to accurately calculate process variables and burner efficiency.

The 1732 Oxygen Transmitter has been designed with flexibility and integration as its key features. It can operate as a stand-alone controller, or be integrated into monitoring or feedback systems using its range of programmable outputs. Configuration of the device is done using the local keypad and display, which is covered in Chapter 6 in this manual.

Features include: -

Inputs

Two zirconia oxygen probes, heated or unheated
Oxygen range from 10⁻³⁰ to 100%
Furnace, kiln or flue thermocouple, field selectable as type K, J, R or S
Main flame established safety interlock (for heated probes only)
Purge pressure or flow switch

Outputs

Two linearized 4-20mA or 0-20mA DC isolated outputs, max. load 1000Ω
The output function and the range are field selectable
Common alarm relay
Three other alarm relays with selectable functions

Digital Interface

RS-232 or two-wire RS-485 MODBUS™ for connection to a computer/DCS/PCL for monitoring of the transmitter, probe or combustion process.

Display

Multi font graphical display
Large font characters for the oxygen on the top line
Selectable lower line items for the secondary display functions. i.e. Probe temperature, Oxygen second probe
Alarm display mode that shows the time of the alarm, the acceptance time and the time that the alarm was cleared of up to 4000 alarm events

2.2 Series 1230 Oxygen Probes & Sensors

Novatech series 1230 oxygen probes and sensors employ state-of-the-art zirconia sensors and advanced materials, which provide the following benefits:

- Improved control due to fast response time to typically less than four seconds
- Cost-efficient design provides improved reliability
- Longer-life probes with greater resistance to corrosion from sulphur and zinc contaminants in flue gas
- Low cost allows maintenance by replacement
- Reduced probe breakage due to greater resistance to thermal shock and mechanical damage during installation and start-up

Series 1230 probe or sensors are simple to install and maintain. All models provide direct measurement of oxygen level. On-line automatic calibration check is available if required. Probes or sensors may be used with Novatech oxygen transmitters and some model transmitters from other manufacturers.

All Novatech oxygen probe or sensors are designed and manufactured to exacting standards of performance and reliability. Series 1230 probe or sensors are the result of extensive research and development by Novatech, industry and government agencies. Novatech Controls provides application and after sales support for oxygen probes, sensors and transmitters, worldwide.

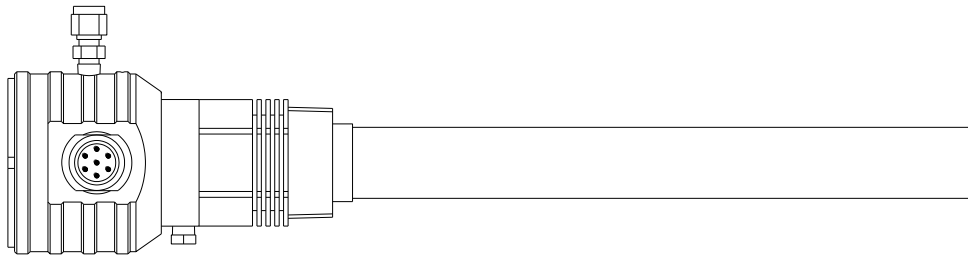

Model 1231 Heated Oxygen Probe

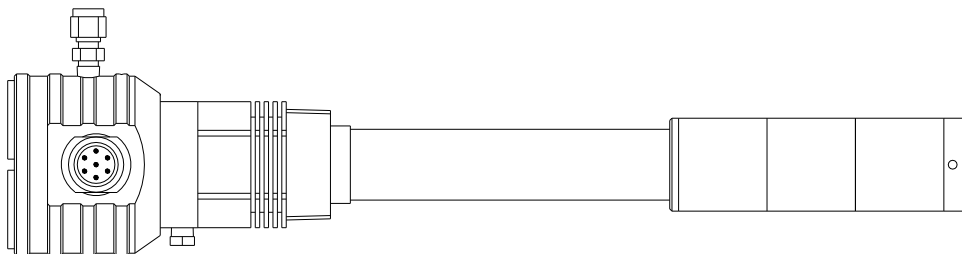

Model 1231 Heated Oxygen Probe with Filter

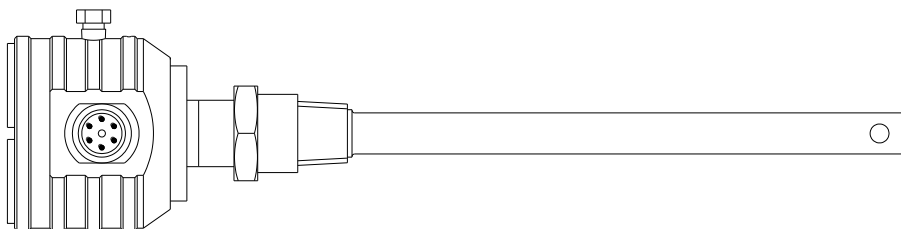

Model 1232 Unheated Oxygen Probe

3. DEVICE SPECIFICATIONS

3.1 Hardware Specifications

3.1.1 Transmitter Specifications

Number of Oxygen Probes:	1 or 2
Oxygen Range:	1 x 10 ⁻³⁰ to 100%
Oxygen Accuracy:	±1% of actual measured oxygen value with a repeatability of ±0.5% of the measured value
Thermocouple Types:	Type K and J
Temperature Accuracy:	±2°C

Analog Outputs: 0-20mA or 4-20mA field selectable
Active Outputs

(WARNING: DO NOT LOOP POWER OUTPUTS. Use only passive receivers for commissioning and testing. The use of loop powered receivers will damage the output)

Output Load: 1000 ohm max

Alarm Relays: 4

Alarm Relay Contacts: 2A 240VAC, 2A 30VDC
Reinforced insulation when used with mains voltage

(WARNING: Do not use both mains voltage and low voltage connections to adjacent alarm contacts)

Mains Voltage Supply: 100 to 240VAC 50/60 Hz
Reinforced insulation

Overvoltage: Category II (IEC60364-4-443)

Power: 5 Watts for controller plus probe power
530W max., 25% duty cycle each probe on 240VAC
110W max., 100% duty cycle each probe on 110VAC
576W (2.4A) max

Environmental Rating: Operating Temperature -25°C to 55°C
Relative Humidity 5% to 95% (non-condensing)

Altitude 2000m Maximum

Degree of Protection: IP65
IP54 with internal reference air pump

Case Size: 315mm (12.4") wide, 190mm (7.5") high, 110mm (4.3") deep

Case Weight: 3.3 Kg (7.3 lbs.)

WARNING: All signal level connections onto the transmitter must be treated as safety extra-low voltage (SELV) as defined in the standard IEC61140. Double insulation must be used when connecting these terminals to systems that might carry high voltage.

3.1.2 Series 1230 Probes Specifications

MODEL	1231 Heated Probe	1232 Unheated Probe
Application	In-Situ probe Process gasses below 900°C (1650°F) Refer to note 1	In-Situ probe Process gasses above 700°C (1290°F)
Temperature Range	0 to 900°C. Refer to note 2 (32 to 1650°F)	Stainless Steel: 700°C to 1000°C (1290°F to 1830°F) Alumina Ceramic: 700°C to 1400°C (1290°F to 2550°F)
Length	Standard Lengths: 250 mm (10") 350 mm (14") 500 mm (20") 750 mm (30") 1000 mm (40") 1500 mm (60")	Standard Lengths: 500 mm (20") 750 mm (30") 1000 mm (40")
Outer Sheath Material	316 Grade Stainless Steel standard (Inconel with all Inconel wetted parts optional)	253MA Grade Stainless Steel standard (Alumina Ceramic optional)
Process Connection	1½" BSPT or NPT	¾" BSPT or NPT
Electrical Connection	Weatherproof plug-in connector or optional screw terminals. The plug connector can be supplied with the cable.	
Cable	Order a specific length with the transmitter	
Filter	Removable sintered titanium alloy particulate filter 30-micron standard, optional 15- micron available. Refer to note 2	Not Available
Integrated Heater	Yes	No
Thermocouple	K, integral	None or R, integral as standard (K, integral by special request).
Response Time	Typically < 4 seconds	Typically < 1 second
Head Temperature	-25 to 100°C (-15 to 210°F) with weatherproof connector -25 to 150°C (-15 to 300°F) with screw terminals	
Reference Gas	Ambient air, 50 to 150 cc/min (3 to 9 scim). Pump can be supplied with the transmitter	
Ref Air Connection	¼" tube	Integral air-line in probe cable. Barbed fitting to 3/16" ID PVC tube
Calibration Check Gas Connection	⅛" NPT female	⅛" NPT female
Weight	2 kg (4.4 lb) plus 165 g (5.8 oz.) / 100 mm (4") length	1 kg (2.2 lb) plus 100g (3.5oz) / 100 mm (4") length

Notes:

- Care must be taken to avoid contact with explosive or inflammable gases with 1231 heated probes and 1234 oxygen sensors when hot. Novatech transmitters have built in safety protection.
- Process gas temperature must be below 800°C if the filters are fitted.

Please contact factory for corrosives other than sulphur or zinc. We can provide test materials to try in your atmosphere.

3.1.3 Model 1234 Sampling Sensor Specifications

Application	Sampling Sensor Used in RGS-17 Reference Gas Sensor
Range of Measurement	<1ppm to 100% Oxygen
Accuracy	±1%
Process Connection	¼" NPT female, inlet and outlet
Electrical Connection	Weatherproof plug-in connector or optional screw terminals. The plug connector can be supplied with the cable.
Cable	Order a specific length with the transmitter
Heater	Yes
Sample Flow Rate	1 to 5 litres per minute (2 to 10scfh)
Differential Pressure	80 to 800 mmWG (3 to 30inWG)
Thermocouple	K, integral
Response Time	Typically <1 second
Reference Gas	n/a
Dimensions	300 x 125 x 85 mm (11.81" x 4.92" x 3.46") HxWxD
Weight	2.2 kg (4.8 lb)

3.1.4 Probe Ordering Information

When ordering an oxygen probe please specify the following required options:

1. Probe to be heated or unheated
2. Probe insertion length (from process end of mounting thread to probe sensing tip)
3. Mounting thread for the process connection, BSP or NPT (for size of thread refer to specifications).
4. Lagging extension length, if required.
5. Electrical Connection Type.
6. Outer Sheath Material, if not specified will assume 316 stainless steel
7. For model 1231 heated probe state filter type if required. If not specified will assume no filters
8. For model 1232 unheated probe, state thermocouple type. If not specified will assume R-type.

For a list of options for the above requirements refer to the appropriate probe specification tables in the previous section.

3.2 Operational Specifications

Range of outputs:

Function	Minimum	Maximum
Linear Oxygen #1	0 to 99%	1 to 100%
Very low Oxygen #1	0 to 19,990ppm	10 to 20,000ppm
Linear Oxygen #2	0 to 99%	1 to 100%
Very low Oxygen #2	0 to 19,990ppm	10 to 20,000ppm
Average Oxygen	0 to 99%	1 to 100%
Logarithmic Oxygen	0.1 to 20%	Fixed range – refer to appendices
Reducing Oxygen	0 to $1 \times 10^{-30}\%$	0 to 100%
Oxygen Deficiency	-10 to 0%	-10 to 20%
Auxiliary TC Temperature	0 to 100°C	0 to 1600°C
Combustibles	0 to 19,000ppm	0 to 20,000ppm
Carbon dioxide	0 to 5%	0 to 100%
Probe #1 Sensor EMF	0 to 100mV	0 to 1500mV
Probe #2 Sensor EMF	0 to 100mV	0 to 1500mV
Burner Efficiency	0 to 20.0%	0 to 100.0%
No output	Disables the output	

Range of local indication: 1.0×10^{-30} to 100%
 0.01 to 10,000ppm, automatically defaults to % range above 10,000ppm (1%)

Local display, lower line secondary display items:

Function	Range
Probe #1 temperature	Up to 1760°C (3200°F)
Probe #2 temperature	Up to 1760°C (3200°F)
Probe #1 EMF	-30 to 1350mV
Probe #2 EMF	-30 to 1350mV
Probe #1 sensor impedance	0 to 300k Ω
Probe #2 sensor impedance	0 to 300k Ω
Oxygen probe #2	1×10^{-30} to 100%
Average oxygen, probe #1 and probe #2	1×10^{-30} to 100%
Aux temperature	Up to 1760°C (3200°F)
Ambient temperature	-20° to 70°C (-5° to 125°F)
Ambient RH	5 to 95%
Carbon dioxide	0 to 2.0%
Combustibles	0 to 20,000ppm
Oxygen deficiency	-10.0 to 20.0%
Burner efficiency	0 to 100.0%

The oxygen deficiency output can be used in the same way as a combustibles analyser to signal the extent of reducing conditions of combustion processes.

4. INSTALLATION AND COMMISSIONING

4.1 Mounting the Transmitter

Surface mount the transmitter case on to a flat surface or bracket, using the four mounting brackets provided. The transmitter should never be mounted so that it is directly exposed to the sun or rain. Always leave at least 10cm of clearance around the four sides of the case.

Make sure the temperature of the case is below 55°C, and that the radiated heat from furnaces and boilers is kept to a minimum. There should be adequate ventilation to maintain ambient temperature.

Install the cables through cable glands. There are 4 holes cut in the base of the transmitter case; 2x 17mm & 2x 21mm. Use a sharp knife to cut away the covering film for only the glands that are needed.

NOTE: ALWAYS LEAVE THE UNUSED GLAND HOLES SEALED.

Ensure that the electrical connection complies with the local electrical requirements. (see chapter 4.6 Electrical Connections)

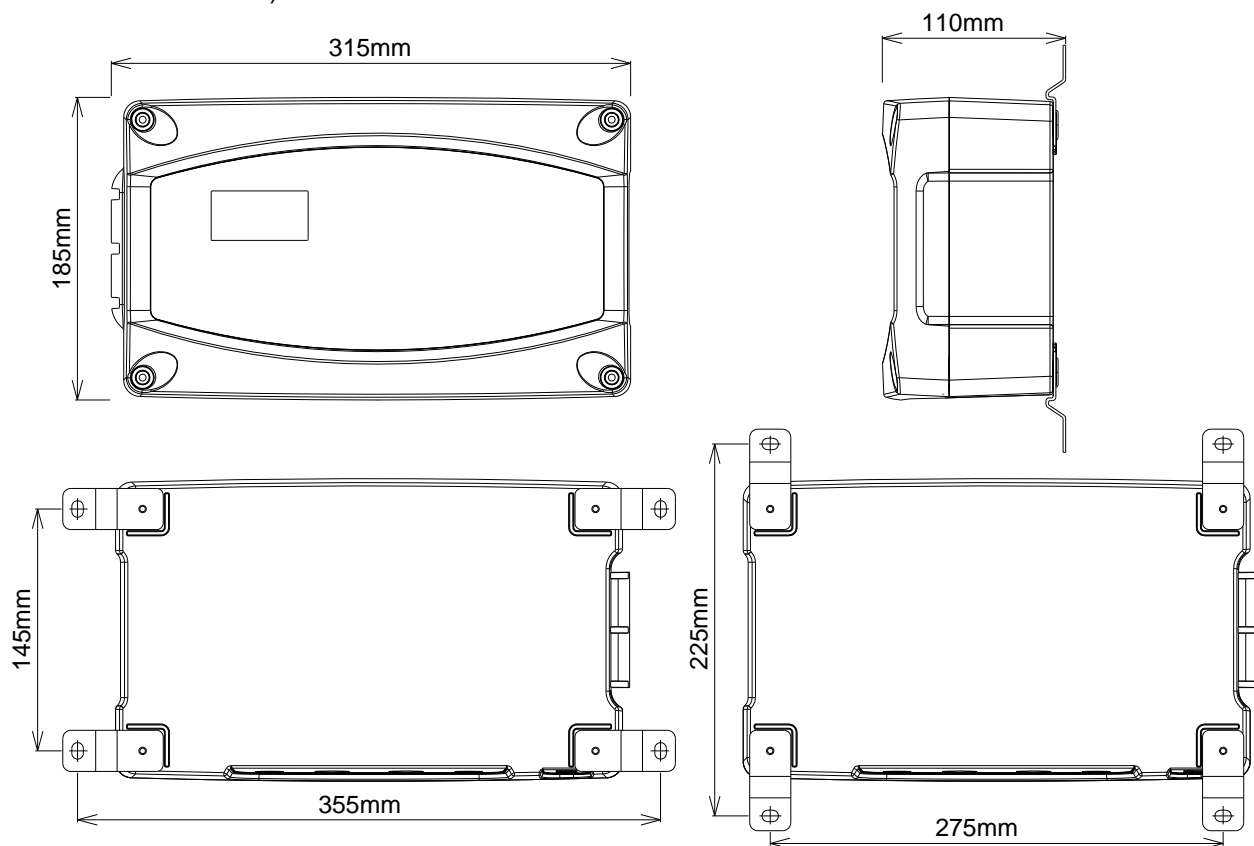

Case Mounting Dimensions

4.2 Installing a 1231 Oxygen Probe

Weld a BSP or NPT socket to the flue in a suitable position for flue gas sensing. For the correct size of socket refer to probe data in Chapter 3.1.2 Series 1230 Probes Specifications. The closer to the source of combustion the smaller will be sensing lag time, allowing better control.

The probe has a typical response time of less than four seconds, so most of the delay time is normally the transit time of the gas from the point of combustion to the point of sensing.

Probes can be mounted at any angle. However, if the probe is to be mounted on a vertical duct wall, it is better to angle the probe (approx. 15°) down to avoid process condensation inside the cold end of the probe. If there are any particulates in the flue gas, a filter can be omitted by pointing the probe vertically downwards. Otherwise the transmitter can be configured to automatically purge the filters, or they can be replaced periodically.

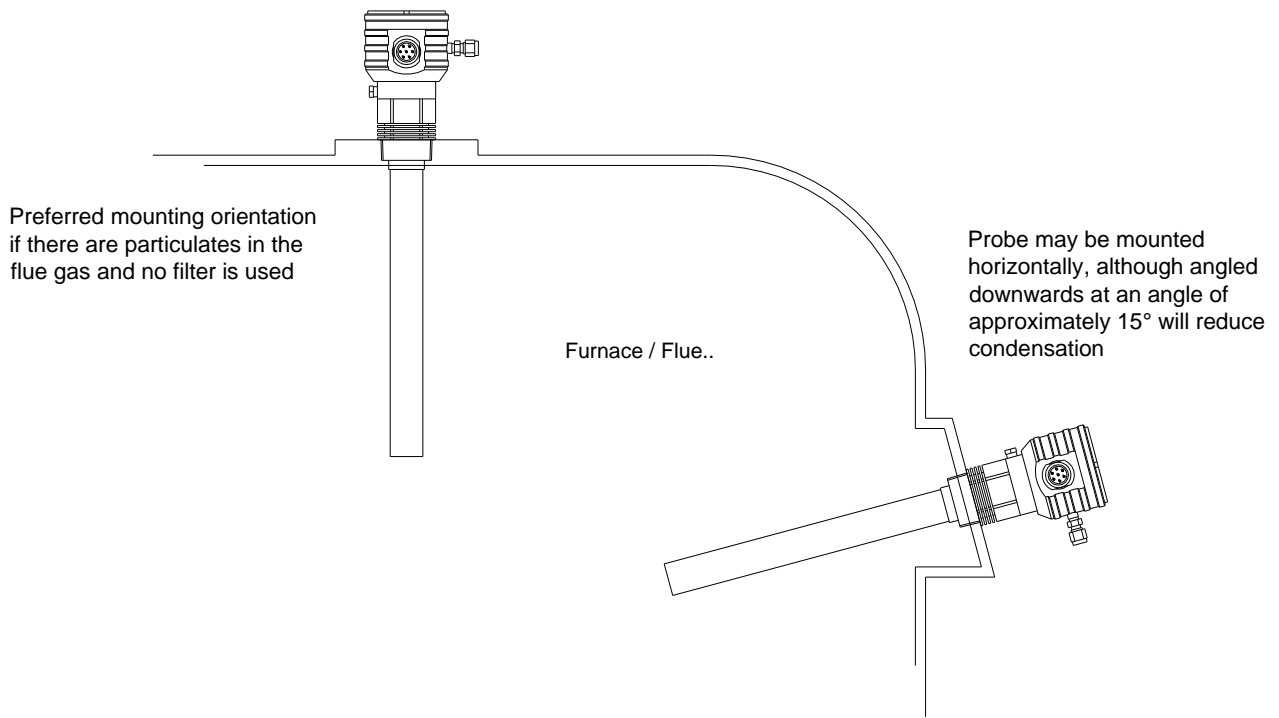

Oxygen Probe Mounting

CAUTION

It is important that there is no air in leakage upstream of the oxygen sensing point otherwise there will be a high oxygen reading.

If the probe is to be installed on a bend in the flue, it is best located on the outer circumference of the bend to avoid dead pockets of flue gas flow. While the standard 1231 probe with a 'U' length of 250 mm (10") will suit most low temperature flue applications, it is occasionally necessary to have a longer probe with the sensing tip in the centre of the flue gas stream.

Although it is rare, occasionally a probe may sense oxygen vastly differently from the average reading in the flue gas. If it occurs, then the probe should be moved, or a longer probe installed. This phenomenon is normally caused by stratification of the flue gas.

4.3 Installing a 1234 Oxygen Sensor

Mounting - Screw the 1234 Oxygen Sensor to a wall or similar surface with the piping connections at the top.

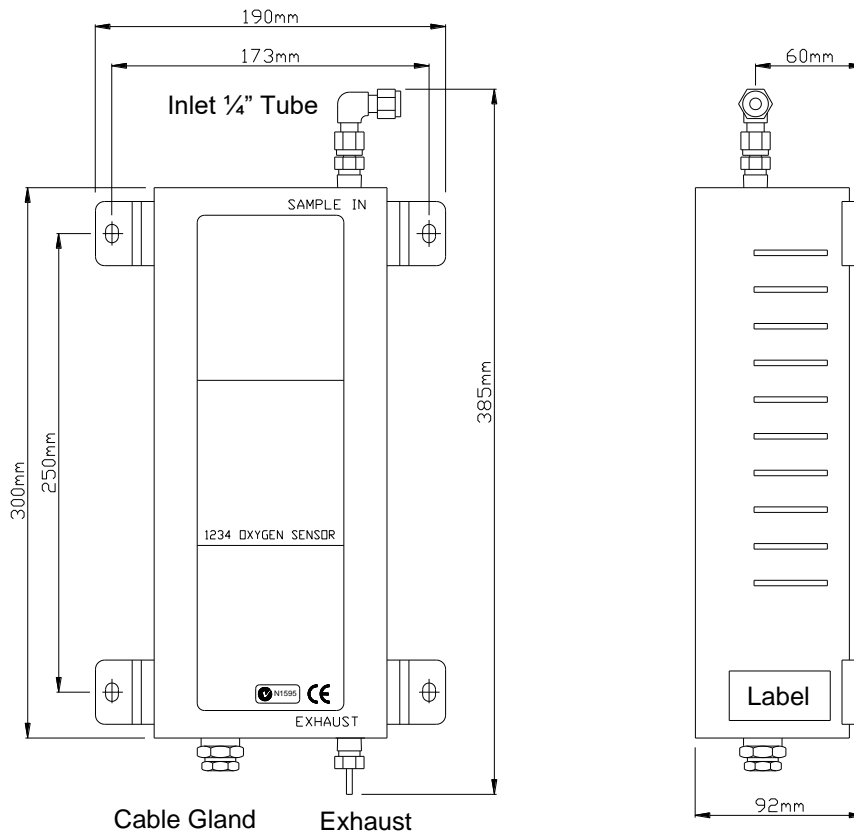

1234 Sensor Mounting Dimensions

Sample Piping - Connect the gas sample piping to the “sample in” port. If the process, boiler, kiln or furnace has a positive pressure, no suction will be required. If the sample is under a negative pressure, connect a pump to the “inlet” port. The flow rate should be within the range of 1 to 5 litres/minute (2 to 10 scfh).

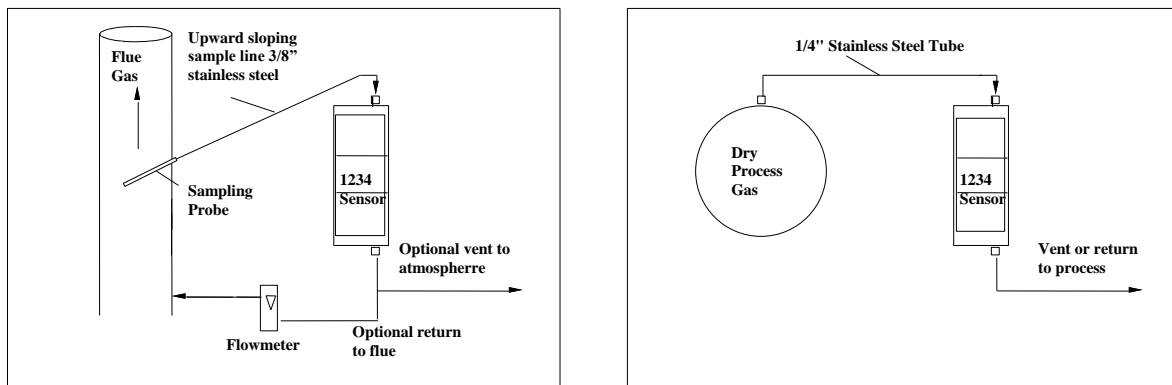

4.4 Installing the Auxiliary Thermocouple

Weld a 1/2-inch BSP mounting socket to the flue within about 300 mm (12”), and upstream of the oxygen probe. The thermocouple should be of similar length to the oxygen probe to prevent flue temperature distribution errors.

The thermocouple should be connected to terminals 7 & 8. These terminals will not be available for an auxiliary thermocouple if a second probe has been installed.

4.5a Shield Connections

All external wiring to the 1732 transmitter should be shielded. Do not connect shields at the field end. Simply clip off and insulate. There are two M4 earth screw terminals available in the 1732 transmitter. An extra terminal strip may be required to connect all shields together. This should be supplied by the installer.

4.5b Earth connection (PE)

The PE (protective earth) input connection must be made to the earth stud on the right hand side of cabinet. The PE input connection must be the first connection onto the earth stud and it must be secured by a separate nut and spring washer. All other earth connections (bonding connections) can be made on either of the two earth studs in the base of the cabinet.

The transmitter MUST be securely earthed.

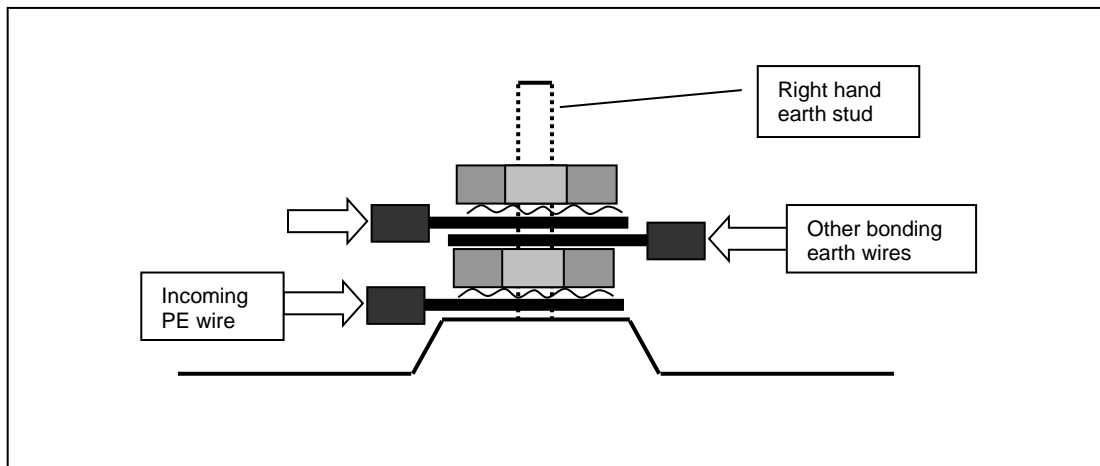

Assembly of the PE and bonding connections on the earth stud

4.6 Electrical Connections

All wiring should comply with local electrical codes. The printed circuit boards are fully floating above earth. The incoming safety earth (PE) must be connected to the primary earth stud in the right-hand side of the base cabinet.

The local fuse for the mains power supply, the isolation switch and the supply wiring must all comply with the electrical safety codes and must only be installed by qualified technicians.

All earth and shield connections should be connected to the earth screws inside the case.

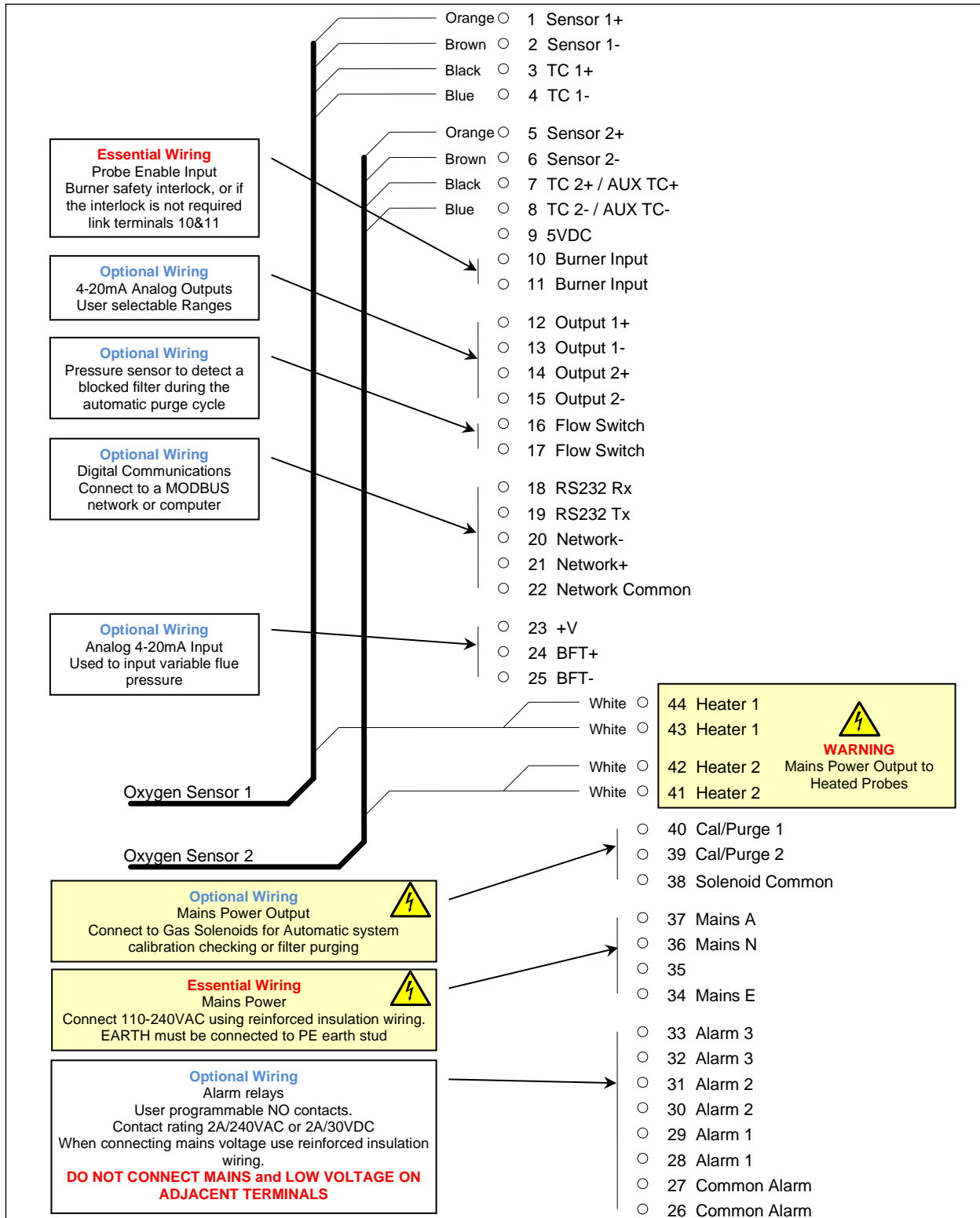

Connection Diagram for 1732 Transmitter and one or two 1231 / 1234 Heated Sensors

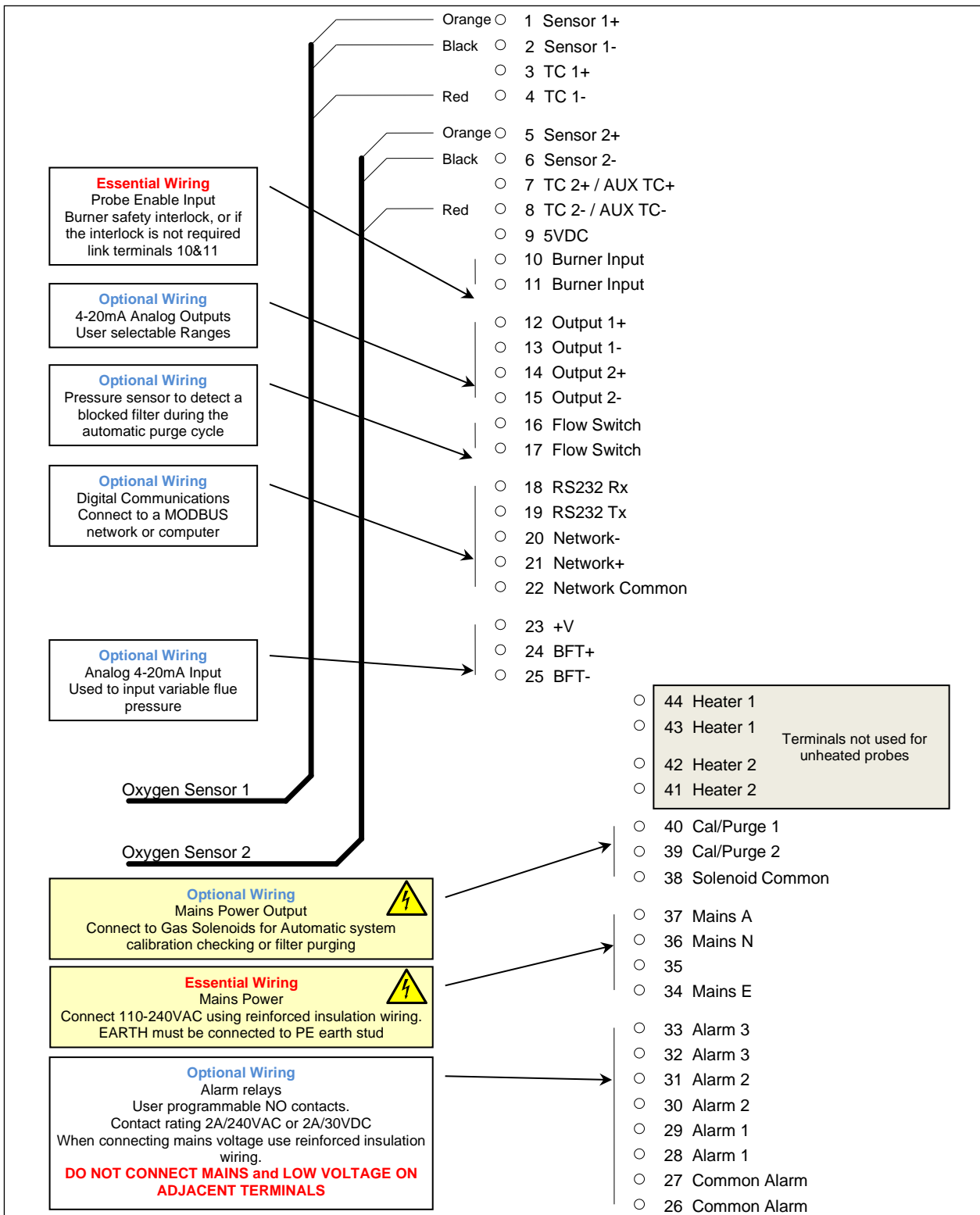

Connection Diagram for 1732 Transmitter and one or two 1232 Unheated Probes

- The mains power must be either 100/110VAC or 220/240VAC with a mains frequency of 50 or 60Hz
- The supply circuit must be fused to at least 10Amps and have a dual pole isolation switch within easy access of the oxygen transmitter. The isolation switch must be marked as the isolation switch for this

equipment. It is recommended that a separate isolation switch be used for each transmitter so that a transmitter can be serviced individually.

- The power supply cables must be supplied and installed according to local regulations
- The earth connection must comply with the local regulations must have a current carrying capability equal or greater than the supply fuse current rating
- The earth connection must be connected to the primary earth stud inside the transmitter on the right-hand side
- All other bonded earth connections from the external wiring must be connected to the primary earth stud

All operations relating the electrical wiring and installation must be carried out by qualified persons in accordance with the safety regulations and the wiring rules.

NOTE: The power switch in the transmitter can be used to turn off the transmitter. There must be an approved isolation device installed to provide complete isolation of the mains power to the transmitter. The mains wiring terminal must not be used as a disconnect device.

4.7 Heater Interlock Relays

CAUTION

Explosion protection for heated probes is achieved by switching the power to the probe heater off whenever the main fuel valve is closed.

The principle of safety is that if the main fuel valve is open then main flame has been established. With this primary source of ignition on, the probe heater can be safely switched on. The most dangerous situation is if fuel leaks into the combustion appliance when the fuel valve is closed. When power is removed from the main fuel valve the heater should also be switched off.

To achieve this protection, connect a main fuel valve voltage free contact to the 'BURNER INPUT' terminals 10 & 11. When the main fuel valve is open, the voltage free contact should be closed. For installations where there is no risk of explosion, connect a link between terminals number 10 & 11.

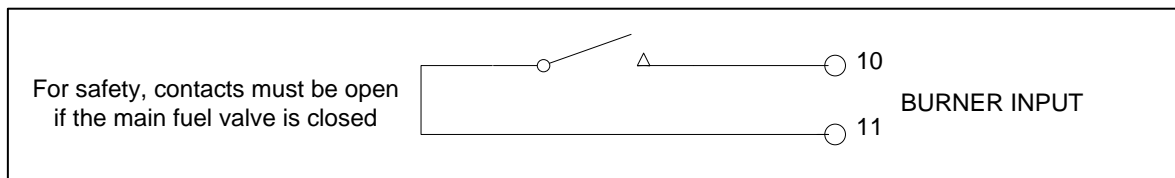

Heater Supply Interlock Connection for Heated Probes

If a safety interlock is not required, a wire must be connected between terminals 10 & 11 to enable –

- The heaters on heated probes
- Process alarms
- Auto-purge and auto-cal checking
- Run time timer

4.8 Connecting an Oxygen Probe Cable

Connect the probe lead as shown in the following drawings. Unheated probe leads have integral reference air tube. An adaptor has been supplied to connect this tube to quarter inch flexible PVC tubing, from the air pump or reference air supply.

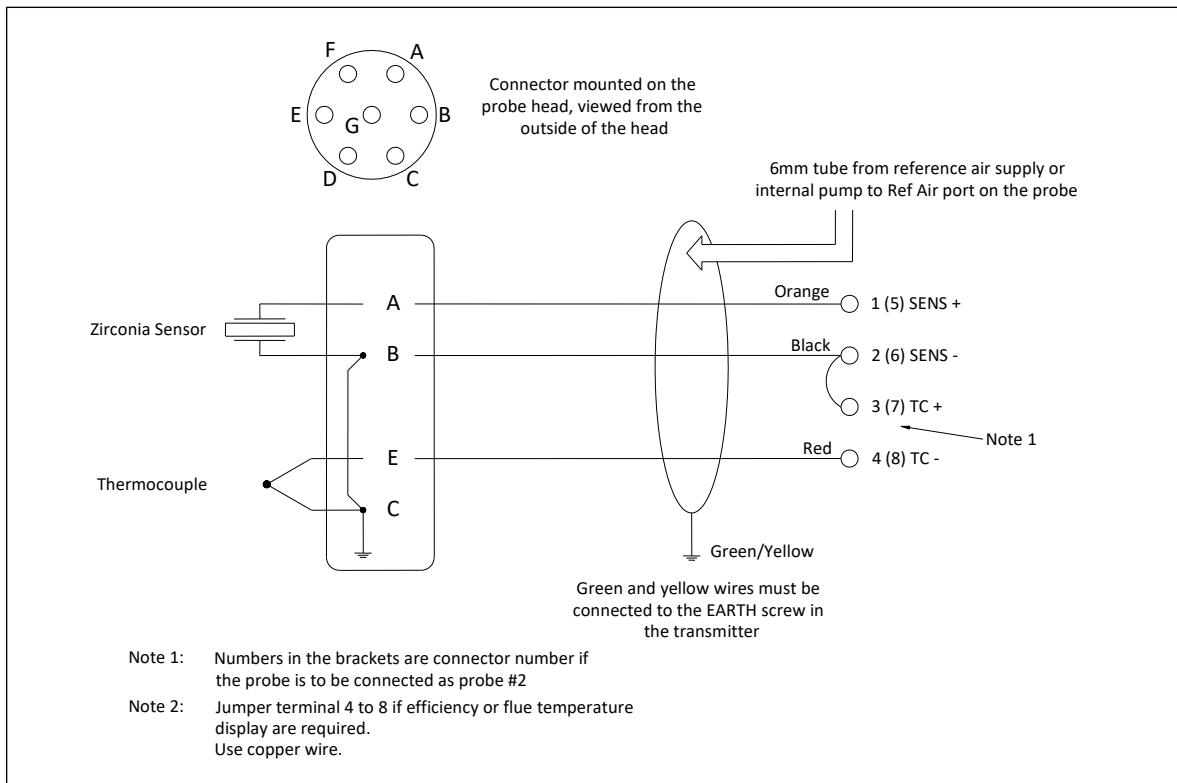

Connection of Probe Cable for Unheated Probes Models 1232.

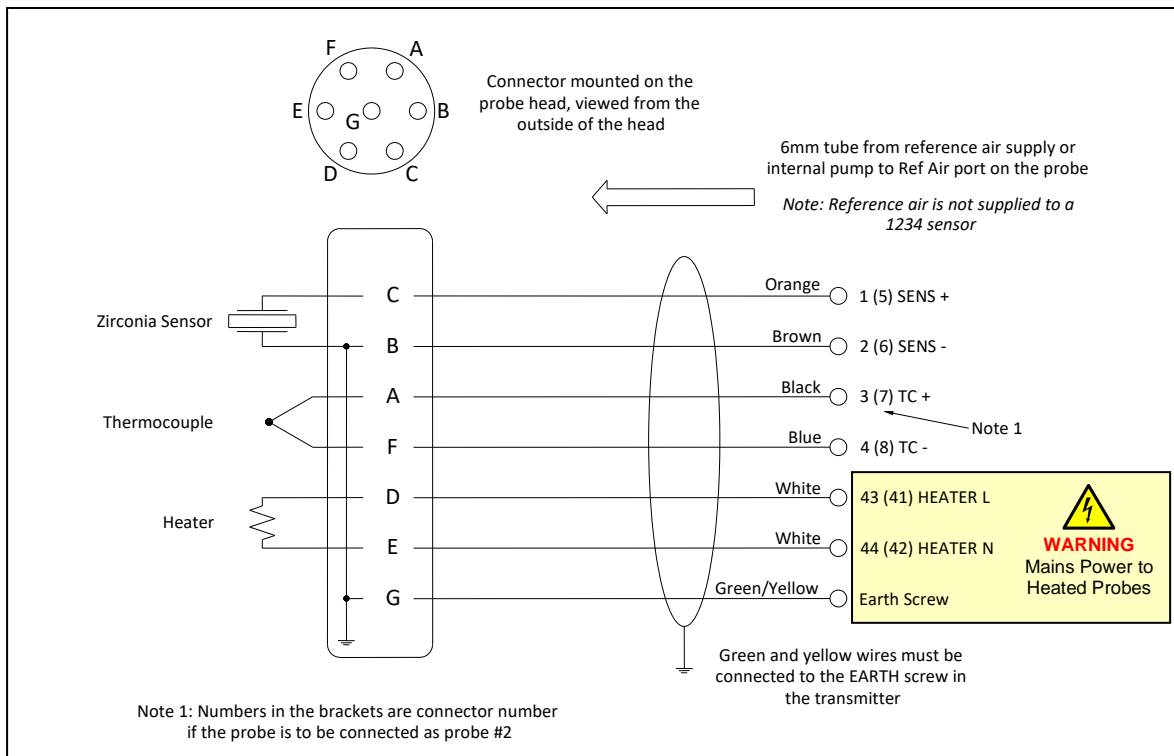

Connection of Probe Cable for Heated Probes Model 1231 and 1234.

4.9 Connecting a 1234 Sensor Cable

The 1234 will either be supplied with a weather proof connector or direct cable wiring.

If the 1234 has a weather proof connector, it will have been supplied with a cable that is already terminated with a matching plug. The other end of the cable can then be terminated in the 1732 transmitter as shown in the 1231 / 1234 wiring diagram on the previous page

If the 1234 has been supplied without the weather proof connector, remove the cover of the 1234 and connect the wires to the connectors on the circuit board as shown below.

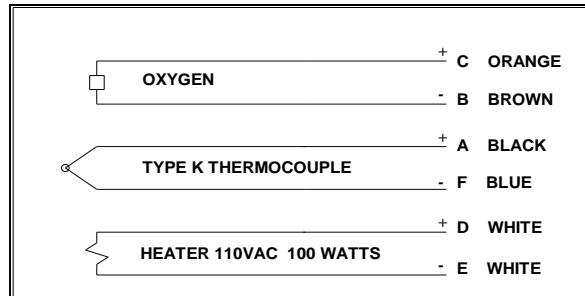

Connecting a 1234 Sensor Cable

4.10 Connecting the Auxiliary Thermocouple (optional)

For 1231 heated probes, the auxiliary thermocouple must be a separate TC with the junction isolated from earth, mounted near to and upstream of the oxygen probe. It can be either a K, J, R or S type thermocouple. It is optional. If the auxiliary temperature or combustion efficiency is not to be displayed or transmitted, then an auxiliary thermocouple is not necessary.

The thermocouple should be connected to terminals 7 & 8. These terminals will not be available for an auxiliary thermocouple if a second probe has been installed.

4.11 Connecting the Output Channels

The two active-powered 4-20mA DC output channels are capable of driving into a 1000Ω load. The output terminals are 12 & 13 for channel 1, and 14 & 15 for channel 2.

4.12 Connecting the Alarms

A common alarm, which should be connected for all installations initiates on alarm functions described below. Three additional alarm relays are available for selectable functions as listed in chapter 9.3 Process Related Alarms. Each relay has normally open contacts. The contacts will open in alarm condition. Relays are connected as follows:

Relay	Terminal Numbers
Common Alarm	26 & 27
Alarm 1	28 & 29
Alarm 2	30 & 31
Alarm 3	32 & 33

Common Alarms All of the following conditions will cause a common alarm -

Probe 1 / Probe 2 Heater Fail	Alarm Log Fail
Probe 1 / Probe 2 High Impedance	ADC Calibration Fail
Probe 1 / Probe 2 TC Open Circuit	Output 1 / Output 2 Failure
Aux TC Open Circuit	Heater 1 / Heater 2 SSR Failure
Ref Air Pump Fail	Heater SSR Leakage
Ref Air Pump Overload	Probe 1 / Probe 2 Filter Blocked
BGRAM Fail	Gas 1 / Gas 2 Calibration Error

The watchdog timer is a special alarm. There will not be an alarm message displayed, but the transmitter will reset.

Alarms can be accepted by pressing the ALARM Δ button (viewing the alarm messages) and then the ENTER button.

Alarm Relay 2 to 4 Select any one or all of the following for each relay. See Chapter 9. Alarms

- | | |
|------------------------------|---|
| High Oxygen 1 / Oxygen 2 | Probe 1 / Probe 2 Temperature Low |
| Low Oxygen 1 / Oxygen 2 | Calibration Check 1 / Check 2 in Progress |
| Very Low Oxygen 1 / Oxygen 2 | Probe 1 / Probe 2 Purge in Progress |
| Oxygen Deviation | |

4.13 Connecting the Automatic Purge and Calibration Check System

CAUTION

The purge and calibration solenoid valves are supplied with mains voltage. This supply has electrical shock danger to maintenance personnel. Always isolate the transmitter before working with the purge and calibration solenoid valves.

The on-line auto purge and calibration check system is optional. For details on its operation see chapters 4.19 Filter Purging, 4.20 Calibration Gas Check and Chapter 11. Gas Calibration Check and Purge.

To automatically sense a blocked probe filter, a flow switch should be installed in the 'purge' line to the probe 'CAL' port. It should be adjusted so that it energises just below the purge flow with new or clean filters installed. The flow switch contacts should be connected to terminals 16 & 17 (FLOW SW).

If the filter is still blocked or partly blocked after an auto purge cycle, the flow switch will not energise and will therefore cause a 'Probe1 (2) Filter Blocked' alarm.

After installation the purge/cal system should be tested thoroughly for leaks. Any leaks can cause significant errors if the flue is at negative pressure. If the flue is at positive pressure, an outward leak can cause corrosion in the purge/cal system piping and fittings.

If probe/filter purging is required but a "Probe1 (2) Filter Blocked" alarm is not required, do not install the flow switch but link terminals 16 & 17.

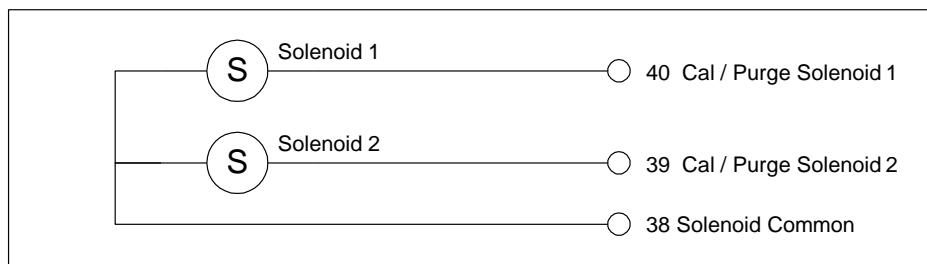

Automatic Purge & Calibration check System Wiring Schematic

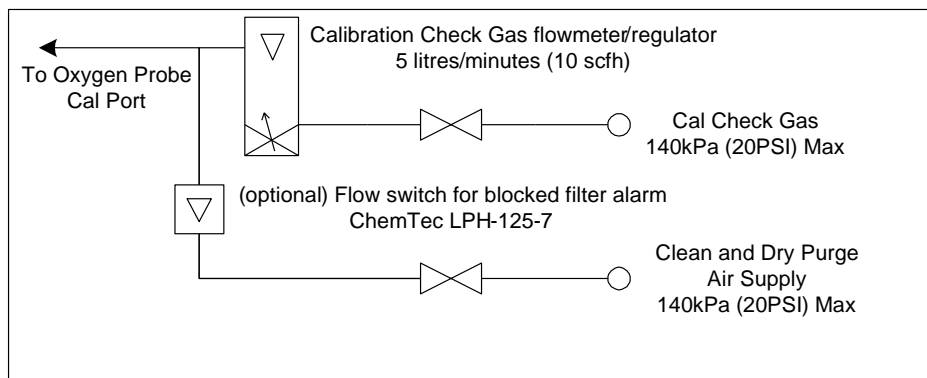

Automatic Purge & Calibration check System Piping Schematic

4.14 Connecting Reference Air

For 1234 sensors, no reference air connection is required. For oxygen probes, a 1/4" tube connector on the transmitter should be connected via a nylon, copper or stainless-steel tube to the 'REF' connector on the probe.

If two probes are being used, a "T" fitting must be supplied to provide reference air supply to both probes.

4.15 Connecting the Transmitter to a MODBUS™ network

The transmitter can be networked to other transmitters and to a network master. The network uses the transmitter's RS485 port. Up to 31 transmitters can be connected to the network, and can be interrogated by the Network Master.

NOTE: Hardware Protocol Selection

The communications port of the 1732 can be configured to communicate on either RS232 or RS485. If the transmitter is to be used on a MODBUS network, the 1732 transmitter must be set to RS485. For further details see chapter 7.2.27 Communications Port Options.

NOTE: Terminating Resistor

There is a terminating 100 ohm resistor fitted to the 1730-1 PCB. Link LK3 (TERM), in the bottom left-hand corner of the PCB, is used to connect the terminating resistor. Link LK3 must be removed on all transmitters except the transmitter on the end of the network line. If the network line from the transmitters is taken from the middle of the transmitter network string, a terminating resistor should be enabled with LK3 at each end of the network line.

The MODBUS™ protocol of the network is –

Baud Rate	19,200
Parity	Even
Stop Bits	1
RS485	2-wire (half duplex)
Mode	RTU (binary mode)

For more details see Appendix 4, MODBUS™.

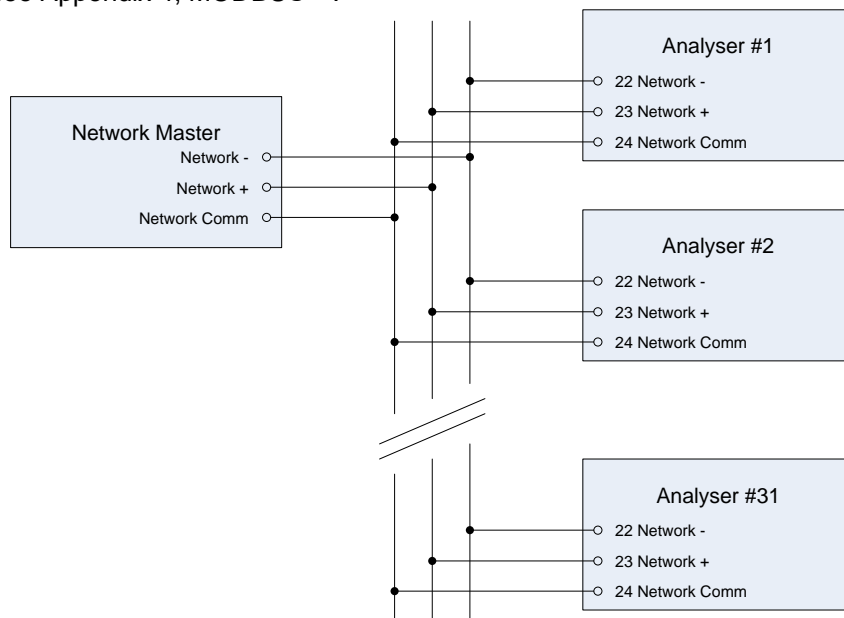

4.16 Connecting Power

Before commissioning the probe, sensor or transmitter, read the CAUTION paragraphs at the front of this manual. The green & yellow EARTH wire MUST be connected to earth.

4.17 Commissioning - Run Mode

When the transmitter is turned on it will go to RUN mode. The SET-UP/RUN button will toggle between the two modes. The upper line of the display will now read '% OXYGEN'. If the probe or sensor temperature is not above 650°C (1200°F), a "Probe Low Temperature" message is flashed on the lower line. The probe or sensor temperature can be checked on the lower line of the display.

4.18 Probe or Sensor Calibration

The zirconia sensor provides an absolute measurement of oxygen partial pressure. There are no calibration adjustments, apart from 'Probe 1 Offset', for the probe. The zirconia sensor EMF is either correct or it needs to be replaced. To check that the probe is functioning correctly, first check that the high impedance alarm, 'Probe 1 (2) High Impedance', is not active. The actual impedance can be displayed on the lower line. It should be less than 9 K Ω at 720°C (1320°F).

Once it has been established that the impedance is normal, the offset may be set using the millivolt value marked on the oxygen probe. See chapter 6.4.1 Probe 1 Offset. The probe offset can be tested on site. A small flow of air must be admitted to both the 'REF' and 'CAL' ports when testing the probe offset. If the probe is in the process, the air must fully purge the probe sensor without interference from the process gas sample. Novatech probes can easily achieve this with or without a probe filter and a gas flow of only 1 to 5 litres/minute (120 to 600 scfm) for a 1231 probe and up to 20 litres/minute (2400scfm) for an unheated probe. When a stable oxygen reading has been achieved, read the 'Probe EMF'. Enter this value into the set-up menu #1 for the probe 1 (set-up #2 for the second probe if it is installed).

4.19 Filter Purging

Purging probe filters is controlled from the 'GAS/PURGE' buttons on the transmitter when in 'RUN' mode. If 'Automatic' has been selected in either 'Sol. 1 Auto/Man' or 'Sol. 2 Auto/Man' in Commissioning Menus 21 or 30, pressing the GAS/PURGE button will start the automatic cycle. Pressing the button again will cancel the auto purge cycle. If 'Automatic' was not enabled, the solenoid will only stay open for as long as the button is pressed. Gradually adjust the purge air supply regulator, increasing the pressure until sufficient flow is obtained to clear the filter. This is best checked with a dirty filter after a period of operation, by withdrawing the probe from service and watching any build up on the filter being blown off at the set pressure. Normally 30 kPa (5 psi) is adequate but the air pressure may be set as high as 100 kPa (15 psi).

4.20 Calibration Gas Check

If the installation has a filter purge facility, set this up first. Refer to the previous paragraph. Press the 'GAS/PURGE 1' or 'GAS/PURGE 2' button while in 'SET UP' mode to obtain a reasonable flow through the calibration check gas flow meter. If air is being used as a calibration check gas, use the air from the regulator for filter purge. Then, when setting up a gas for calibration checking, set the pressure from the calibration gas cylinder so that it is the same as the pressure set on the air regulator. Then the setting on the rotameter / flow regulator will be the same as that for the airflow. The flow required is 1 to 5 litres/minute (120 to 600 scfm) for a 1231 probe and up to 20 litres/minute (2400scfm) for an unheated probe.

Air is not the best gas for calibration checking on a zirconia sensor. The output of a zirconia sensor with air on both sides of the sensor is zero millivolts. It is better to choose a gas value which provides a reasonable output from the sensor and which is near to the process oxygen level. A cylinder with 2% oxygen in nitrogen is a commonly used calibration gas. The maximum pressure on the calibration check gas cylinder regulators is 100 kPa (15 psi).

Note: If 'Dual probe' was selected in commissioning menu 4, 'Cal Gas 2' must be connected to probe 2.

4.21 Dust in the Flue Gas

For unheated probes with no filter, entrained solids or dust in the flue gas does not present a problem unless the dust, when settled, is not porous. Allow the dust in the process to build up on the probe. It will form a porous layer slowing the response time. To avoid mechanical abrasion of the electrode material in installations with unheated oxygen probes, pack 'SAFFIL' or equivalent alumina based ceramic fibre in the sensing holes to protect the electrode. Do not use silica based ceramic fibres such as 'KAOWOOL', which can attack the electrode at high temperatures. Once the dust has built up the response time of the probe will be slower.

For heated probes the preferred method of mounting for dust-laden applications is facing vertically downwards with the filter removed. Probes can also be mounted horizontally with no filter with some dusts. An occasional automatic back purge is helpful in this case.

Normally heated probes are supplied with filters for applications with particulates in the flue gas. The probe response time should be tested when the probe is first installed, and then regularly until it remains constant for a significant period. Filter purging should be set up on the time periods determined by these tests. To test the probe response time, use a stopwatch to obtain the time for a probe to achieve a 63 % change from one reading to another. If a probe filter blocks completely in a short period of time, then there is no option but to use the probe without the filter. A trial probe with filter can be installed to test whether a filter blockage is likely to occur.

4.22 Stratification

If the transmitter and probe have been fully tested and the oxygen readings in the flue gas are incorrect, gas stratification may be occurring. The phenomena cannot be anticipated for any particular installation. Generally, large flues have oxygen differences of approximately one percent across the flue. Occasionally an oxygen error of several percent may occur in a flue of any size. Moving the probe to a new location normally solves this problem.

The effects of stratification can be reduced by using two probes and averaging the two oxygen readings. This can be achieved within a Novatech 1732 transmitter controlling two probes.

4.23 Connecting a Pressure Transducer

If the process gas pressure varies more than 4" WG and therefore requires automatic compensation, connect a pressure transducer as shown below.

Place a link across LK2, near to the input terminals 24 & 25. **If the link is not populated**, you can achieve the same thing connecting a 120Ω resistor across the two terminals.

A pressure change of 4" WG will cause a change in the calculated oxygen reading of approximately 1%.

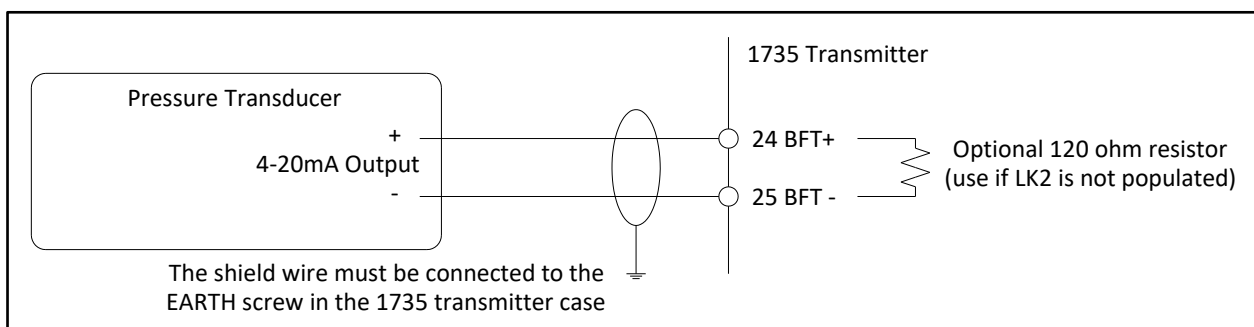

There are no calibration adjustments for the zero or span of the pressure transducer input.

Set the transducer scale range in the Commissioning Menu - See chapter 7.2.9 Flue Pressure Input Units and Value. The pressure can be displayed on the lower line by enabling the corresponding option. See chapter 6.4.2 Lower Line Items

This page has been intentionally left blank.

5. DISPLAY AND KEYPAD

The 1732 Oxygen Transmitter has a graphic display, 8 buttons and 5 LED indicators to show the status of the transmitter.

All of the buttons have multiple functions, depending on what is currently on the display. As a general starting point, the larger white text on the button is the function while the transmitter is in the **Run Menu** and the smaller black text on the button is the function in the **Setup / Commissioning / Calibration Menus**.

When the transmitter is sitting idle it will revert to Run Mode, in which standard information relating to the process appears on the screen. To configure the transmitter, the operator must access Setup Menu. This is achieved by pressing, and in some cases holding down the SETUP button (see Chapters 6, 7 8). The transmitter will return to the Run Mode when the SETUP button is pressed again or after a period of 60 seconds of inactivity.

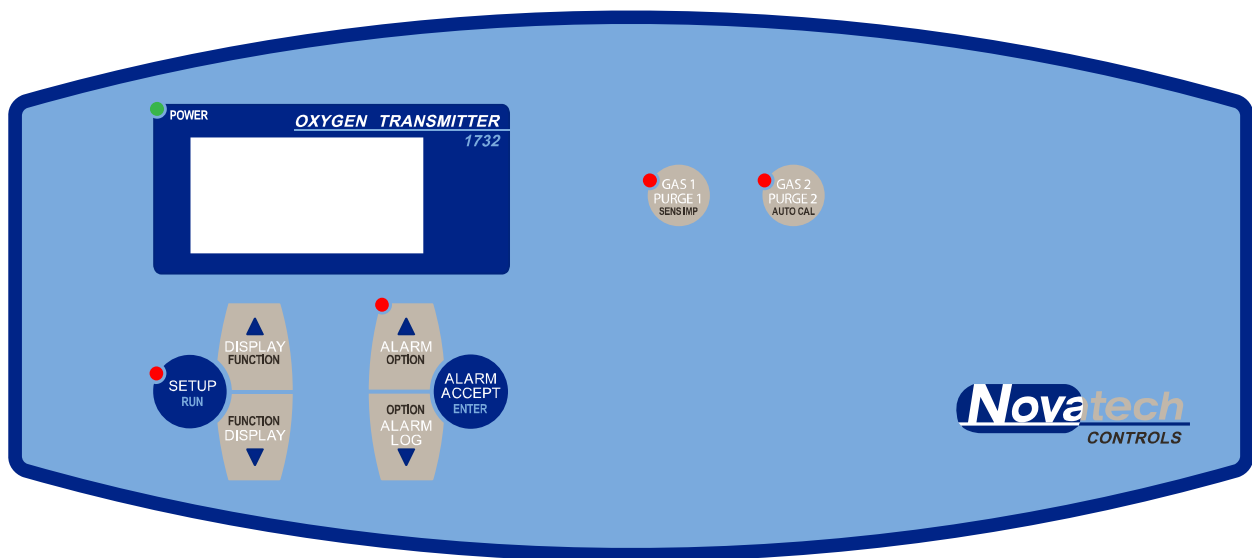

The front panel of the 1732 Oxygen Transmitter

5.1 Run Mode Display

In Run Mode the 1732 shows the first oxygen probe measurement in large characters at the top of the display and a user selectable lower line in smaller characters below. Other items on the display include the activity heartbeat indicator in the top right corner, a row of single letter action indicators in the bottom left corner and the current time in the bottom right corner.

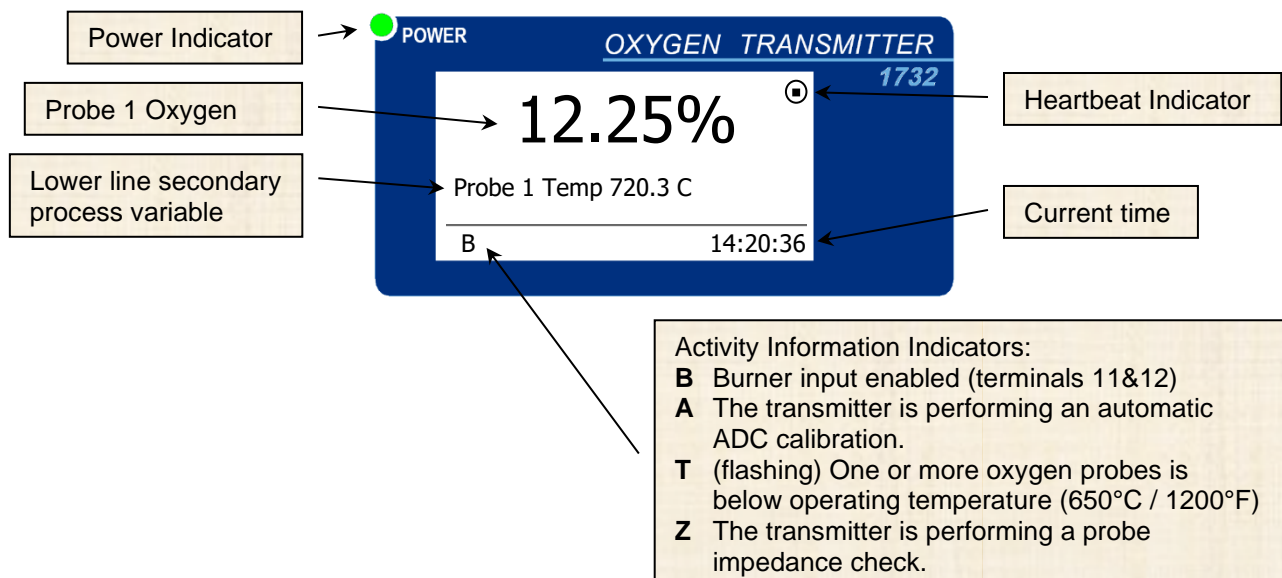

In the Setup Menu the display is replaced with an interactive menu driven interface. While in the Setup Menu all other functions of the transmitter including reading inputs, calculation of process variables, checking of alarm conditions and retransmitting will continue to operate as normal.

5.2 Oxygen Display Units

The measured oxygen content displayed on the top line of the transmitter for probe 1 and on the lower line for probe 2 can be shown in either % or parts per million (ppm). See chapter 6.4.3 Oxygen Display Units for how to change the oxygen display.

The format of the oxygen display changes to maintain the best resolution for the measurement. If 'Oxygen %' is selected the transmitter will display oxygen in the following format:

Range	Display format
30.0 to 100.0%	##.##%
1.00 to 29.99%	##.###%
0.100 to 0.999%	#.###%
< 0.100%	scientific notation (#.## x 10 ^{-##} %)

If 'Oxygen ppm' is selected the transmitter will show the oxygen in ppm format between 10 and 9,999 ppm. Outside of this range the oxygen will be shown in % format described above. Display format for 'Oxygen ppm':

Range	Display format
> 10,000ppm (1%)	% format (see 'Oxygen %' above)
1,000 to 9,999ppm	#,### ppm
100.0 to 999.9ppm	###.# ppm
10.00 to 99.99ppm	##.## ppm
< 10ppm	scientific notation (#.## x 10 ^{-##} %)

5.3 Keypad

There are 8 buttons built into the label on front panel of the 1732 Transmitter. The button functions are written in BLACK and WHITE to identify the function of the button in either Run Mode or the Setup Menu system.

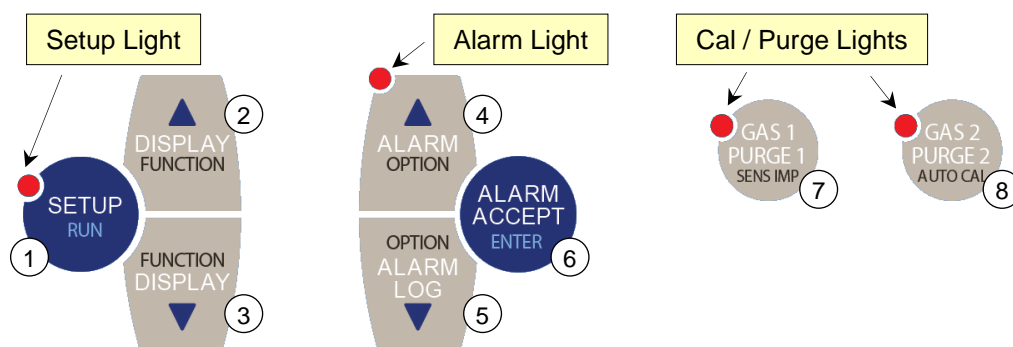

	Button Text	Run Mode (white text)	Setup Menu (black/blue text)
1	SETUP / RUN	Enter Setup Menu	Return to Run Mode
2	DISPLAY / FUNCTION Δ	Display next Lower Line item	Next function
3	DISPLAY / FUNCTION ∇	Display last Lower Line Item	Previous function
4	ALARM / OPTION Δ	Next alarm	Next / increment option
5	ALARM / OPTION ∇	Previous alarm	Previous / decrement option
6	ALARM ACCEPT / ENTER	Acknowledge displayed alarm	Save current option
7	GAS 1 PURGE 1 / SENS IMP	Gas 1 / Purge 1 manual activate	Check Probe impedance
8	GAS 2 PURGE 2 / AUTO CAL	Gas 2 / Purge 2 manual activate	Manually perform device calibration

5.3.1 Keypad in Run Mode

After the transmitter is powered on and has completed its initial startup procedure, it will enter the Run Mode. The button functions in this mode are as follows;

SETUP / RUN

By pressing this button once from Run Mode the transmitter will enter the Setup Menu system. In the Setup Menu the function of each of the buttons is reassigned. Pressing the SETUP / RUN button a second time while in the Setup Menu will return the transmitter to the Run Mode. If the transmitter is left idle in the Setup Menu for more than 60 seconds, it will automatically return to Run Mode.

DISPLAY Δ / DISPLAY ∇

The display buttons are used to scroll the lower line up and down through the variety of measurements that are available on the lower line. For a complete list of options see chapter 6.4.2 Lower Line Items.

ALARM Δ

If there is either a new alarm or an active alarm the ALARM Δ button can be pressed to examine the alarm status. The Alarm Light will be flashing if there is a new alarm or steady if there is an existing alarm. For more details on the ALARM MODE and buttons see Chapter 9. Alarms. The Setup Light will flash slowly to show that the transmitter is now in the alarm display mode.

ALARM ∇

When the transmitter is displaying active alarms (the ALARM Δ button has been pressed), the ALARM Δ button and ALARM ∇ button allow the operator to examine the date / time of the alarm and the date / time that the alarm was acknowledged.

If the transmitter was in Run Mode when this button is pressed it will go into the alarm log display mode. See Chapter 9. Alarms for more details.

ALARM ACCEPT

Press this button to acknowledge the currently displayed alarm (See Chapter 9. Alarms).

GAS 1 / PURGE 1 GAS 2 / PURGE 2

These two buttons are used to turn on the gas / purge solenoids. When the transmitter is in the manual cal / purge mode (Commissioning Menu functions #23 and 32) the solenoid will be activated for as long as the button is pressed. When the transmitter is in the auto cal / purge mode the automatic cal / purge cycle is started. The cycle can be stopped by pressing the same button again.

5.3.2 Keypad in the Setup / Commissioning / Calibration Menu

NOTE: Access to the Commissioning Menu and Calibration Menu can be disabled by switching OFF the corresponding slider on DIP switch SW1 on the 1730 Main PCB. To enter either Commissioning Menu or Calibration Menu, the corresponding DIP switch SW1 on the 1730-1 PCB must be turned on.

From Run Mode, if the SETUP / RUN button is pressed once, the transmitter will display the Setup Menu. If the SETUP / RUN button is pressed and held for 2 seconds, the transmitter will display the **Commissioning Menu**. If the SETUP / RUN button is pressed and held for 4 seconds, the transmitter will display the **Calibration Menu**.

The following functions are then available in all of the above modes.

SETUP / RUN

Pressing this button while in the Setup / Commissioning / Calibration Menu will return the transmitter to the Run Mode.

FUNCTION Δ / FUNCTION ∇

These two buttons allow for the selection of the menu function. A function summary table is found at the start of each chapter for Setup Menu, Commissioning Menu and Calibration Menu.

OPTION Δ / OPTION ∇

These two buttons allow for modifying the option for the selected function. A list/range of options for each function is found in the function summary table at the start of each chapter for the Setup Menu, Commissioning Menu and Calibration Menu.

ENTER

This button applies/updates the currently displayed option and stores the value in non-volatile memory to be retrieved on device start up. If this button is not pressed before changing to a new function, then the previous option will be retained.

SENS IMP

When this button is pressed the transmitter will measure the impedance of oxygen probe(s) attached to the transmitter. If the burner is not enabled (terminals 10 & 11) or the probe temperature is below 700°C (1292°F) impedance checking will not be performed. During impedance checking a 'Z' will be seen in the bottom left hand corner of the display.

AUTO CAL

When this button is pressed the transmitter will calibrate the analog output channels that are set to auto calibration (see Chapter 10. Instrument Calibration). This is performed by directing the output current away from the output terminals (terminals 12 & 13 and 14 & 15) back to an analogue input to the transmitter in order to calculate a zero and span calibration factor for each of the output channels.

During this process normal output to the analog channels will be interrupted sending the outputs open circuit.

6. SETUP MENU

This chapter describes the functions available when the Setup Menu is entered on the transmitter.

The Setup Menu is mode is accessed from Run Mode by pressing the SETUP button momentarily so the words 'Setup Menu' appear at the bottom of the display. The transmitter will return to the Run Mode when the SETUP button is pressed again or after 60 seconds of keypad inactivity.

6.1 Function Summary Table

The following table shows a summary of Setup Menu functions:

Menu #	Function name	Range	Default value
01	Probe 1 Offset	±6.0mV	0.0mV
02	Probe 2 Offset	±6.0mV	0.0mV
03	Lower Line Items	see chapter 6.4.2 Lower Line Items	
04	Oxygen Display Units	Oxygen % / Oxygen ppm	Oxygen %
05	Damping Factor	No Damping to 10 Samples	5 Samples
06	Process Alarms	Enabled / Disabled	Disabled

6.2 Setup Menu Display

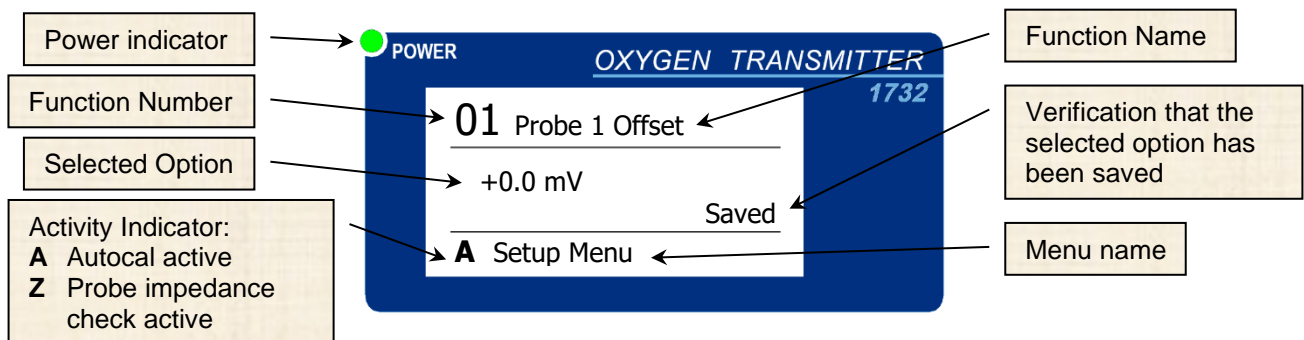

6.3 Changing Menu Options

The purpose of having an interactive Setup Menu is to allow for configuration of the transmitter using the graphical display and keypad.

Once an option is changed and entered using the ENTER button that value immediately becomes active. The device configuration and calibration is stored into the non-volatile memory and will be retained permanently even if the device does not have power.

To reset the transmitter configuration to factory default settings, see chapter 10.2 Cold Start.

To change an option in the Setup Menu system:

1. Enter the Setup Menu by pressing the SETUP / RUN button once. The Setup Light will come on and the display will have the format shown below. The operations of the buttons are now the operations written in WHITE on the keypad. The menu name is written at the bottom of the display.
2. While in the Setup Menu the required function can be selected by using the FUNCTION Δ and FUNCTION ∇ buttons. The options available for that function can be seen by using the OPTION Δ and OPTION ∇ buttons.
3. When the required option is on the display press the ENTER button to save that value.

When finished, press the SETUP / RUN button to return to the Run Mode.

6.4 Setup Menu Functions

6.4.1 Probe 1 Offset

Options: $\pm 6.0\text{mV}$ in 0.1mV increments.

Default: 0.0mV

Each Novatech oxygen probe has an offset calibration value printed on a tag that is attached to the probe when it is dispatched. To achieve the most accurate measurement of oxygen the offset value must be entered into this setup function with the same polarity as it is printed on the label. For a healthy probe the offset value should be within $\pm 1.0\text{mV}$

NOTE: An offset of 1.0mV will change the oxygen reading by approximately 1% oxygen when the probe is in ambient air. However, as the process oxygen measurement drops, this offset will have a diminishing effect. At a process gas oxygen concentration of 2%, the 1.0mV offset error will only change the reading by 0.1% oxygen. If in any doubt about the correct offset value, set it to 0.0mV .

The function 'Probe 2 Offset' will only appear if the transmitter has been configured for 2 oxygen probes.

6.4.2 Lower Line Items

This function allows the operator to change the items that are available to be displayed on the lower line of the transmitter in Run Mode. If the word "Enabled" appears on the display for a selected lower line option, the measurement will be available to be shown on the display in the Run Mode by scrolling through the list using the DISPLAY Δ and DISPLAY ∇ buttons.

Each individual lower line measurement can be enabled or disabled by pressing the ENTER button.

	OPTIONS:	Enabled as Default
1	Temperature, Probe #1	*
2	Temperature, Probe #2	*
3	Sensor EMF, Probe #1	*
4	Sensor EMF, Probe #2	*
5	Sensor Impedance, Probe #1	*
6	Sensor Impedance, Probe #2	*
7	Oxygen, Probe #2	*
8	Oxygen, Average Probe 1 And Probe 2	*
9	Auxiliary Thermocouple Temperature	
10	Ambient Temperature	*
11	Ambient Relative Humidity	
12	Oxygen Deficiency, Probe #1	
13	Oxygen Deficiency, Probe #2	
14	Combustibles, Probe #1	
15	Combustibles, Probe #2	
16	Maximum Theoretical Dry CO ₂ , Probe #1	
17	Maximum Theoretical Dry CO ₂ , Probe #2	
18	Combustion Efficiency	(requires "Single Probe" and "Aux TC Type" to be set)
19	Flue Pressure	
20	Burner Run Time	
21	Service Date	
22	Analog Output 1 4-20mA	
23	Analog Output 2 4-20mA	

NOTE: An asterisk (*) on the end of the line identifies the item is enabled by default after a COLD-START.

6.4.3 Oxygen Display Units

Options: Oxygen % / Oxygen ppm (parts per million).

Default: Oxygen %.

The top line of the display that shows the oxygen measurement can be displayed in either % or ppm (see chapter 5.2 Oxygen Display Units)

6.4.4 Damping Factor

Options: No Damping
1 – 10 Samples Averaged

Default: 5 Samples

The Oxygen measurement can be damped by averaging successive readings from the probe. This can be used to smooth out minor fluctuations in the process gas level and should improve the stability of the readings of the system. The larger the number selected here, the more successive readings are averaged and the smoother the measurement will be.

The damping factor is not applied to the Probe EMF and Probe Temperature values used to calculate oxygen, but to the oxygen value itself. The pre-damped oxygen value is not displayed or retransmitted via digital or analog outputs, when damping is enabled the damped oxygen value is shown on the local display as well as being retransmitted via digital or analog outputs.

6.4.5 Process Alarms

Options: Enabled / Disabled

Default: Disabled

This function allows the operator to enable and disable process alarms. The process alarm menu functions will also be hidden if the process alarms are disabled. (See also chapter 7.2.20 Process Alarms)

This page has been intentionally left blank.

7. COMMISSIONING MENU

This chapter describes the functions available in the Commissioning Menu on the 1732 Oxygen Transmitter.

To Access the Commissioning Menu;

- Ensure the DIP switch SW1-2 on the main PCB is in the ON position
- From Run Mode, press and hold the Setup button for approximately 2 seconds until the words “Commissioning Menu” appears at the bottom of the display.

When the transmitter is in the Commissioning Menu the Setup Light will be on and the words “Commissioning Menu” will be shown at the bottom of the display. The transmitter will return to the Run Mode when the SETUP button is pressed again or after 60 seconds of keypad inactivity.

Changing options in the Commissioning Menu is the same as the Setup Menu. See chapter 6.3 Changing Menu Options.

7.1 Function Summary Table

The following table shows a summary of Commissioning Menu functions:

Menu #	Function name	Range	Default value
01	Internal Clock Date		
02	Internal Clock Time		
03	Service Date		
04	Number of Probes	Single / Dual Probe	Single Probe
05	Probe 1 Type	1231 / 1234 Heated	1231 / 1234 Heated
06	Probe 2 Type	or 1232 Unheated	1231 / 1234 Heated
07	Probe 1 TC Type	K, J, R or S Types	K-Type
08	Probe 2 TC Type	K, J, R or S Types	K-Type
09	Auxiliary TC Type	K, J, R or S Types, Disabled	Disabled
10	Transmitter Output Channel 1		Linear oxygen
11	Transmitter Zero Channel 1		
12	Transmitter Span Channel 1	See chapter 7.2.7 Transmitter Output Channel	
13	Transmitter Output Channel 1		Linear oxygen
14	Transmitter Zero Channel 2		
15	Transmitter Span Channel 2		
16	Flue Pressure Units	Inches WG, mm WG, kPa, PSI	Inches WG
17	Flow Pressure Input	Fixed / Variable	Fixed
18	Flue Pressure Value (Fixed)		0 Inches WG
19	Flue Input Zero	-1 to 3 Atm	0 Inches WG
20	Flue Input Span		100 Inches WG
21	Temperature Units	Celsius / Fahrenheit	Celsius
22	Cal Freezes Outputs	Enabled / Disabled	Enabled
23	Solenoid 1 Operation	Calibration Check / Probe Purge / Begin Sample	Calibration Gas
24	Solenoid 1 Auto / Manual	Automatic / Manual	Manual
25	Solenoid 1 Start Time	00:00 to 23:45	00:00 (midnight)
26	Solenoid 1 Period	1 minute – 7 days	1 hour
27	Solenoid 1 Duration	1 – 90 seconds	30 seconds
28	Solenoid 1 Post Freeze	0 – 300 seconds	60 seconds
29	Oxygen Content Cal Gas 1	0.1 – 20.9%	8.0%
30	Max Cal Gas 1 Positive Error	0.1% to 3.0%	0.5%

Menu #	Function name	Range	Default value
31	Max Cal Gas 1 Negative Error	0.1% to 3.0%	0.2%
32	Solenoid 2 Operation	Calibration Check / Probe Purge / Begin Sample	Calibration Gas
33	Solenoid 2 Auto / Manual	Automatic / Manual	Manual
34	Solenoid 2 Start Time	00:00 – 23:45	00:00 (midnight)
35	Solenoid 2 Period	1 minute – 7 days	1 hour
36	Solenoid 2 Duration	1 – 90 seconds	30 seconds
37	Solenoid 2 Post Freeze	0 – 300 seconds	60 seconds
38	O ₂ Content Calibration Gas 2	0.1% to 20.9%	8.0%
39	Max Cal Gas 2 Positive Error	0.1% to 3.0%	0.5%
40	Max Cal Gas 2 Negative Error	0.1% to 3.0%	0.2%
41	Very Low Oxygen Alarm	0.1ppm to 100%	0.500% (5000ppm)
42	Very Low Oxygen Alarm Delay	0 to 200 seconds	2 seconds
43	Low Oxygen Alarm	0.1ppm to 100%	2.5%
44	Low Oxygen Alarm Delay	0 to 200 seconds	10 seconds
45	High Oxygen Alarm	0.1ppm to 100%	10.0%
46	High Oxygen Alarm Delay	0 to 200 seconds	60 seconds
47	Oxygen Deviation Alarm	0.1ppm to 100%	2.0%
48	Oxygen Deviation Alarm Delay	0 to 200 seconds	30 seconds
49	Alarm Relay 1 Function		
50	Alarm Relay 2 Function		
51	Alarm Relay 3 Function	see Chapter 9. Alarms	
52	Common Relay Function		
53	Accept Relay Hold	Enabled / Disabled	Enabled
54	Z-Test Frequency		
55	Z-Test Start Time	see chapter 7.2.24 Probe Impedance Test Options	
56	Z-Test Post Freeze		
57	Fuel Type Select	see chapter 7.2.25 Selecting the Correct Fuel	
58	Fuel Heat / gram C	0.00 to 300.00	209.90
59	Fuel H / C atom ratio	0.00 to 10.00	3.86
60	Fuel O / C atom ratio	0.00 to 10.00	0.00
61	Fuel N / C atom ratio	0.00 to 10.00	0.10
62	Fuel S / C atom ratio	0.00 to 10.00	0.00
63	H ₂ O Mol / C atom ratio	0.00 to 10.00	0.00
64	Reference Air Pump	Internal / External	Internal
65	Internal Pump Voltage	1.5 to 5.0v	5.0v
66	Reference Air RH %	0 to 80%	55%
67	Serial Interface	RS-232 / RS-485 / Disabled	RS-232
68	Serial Baud Rate	2400 – 115200 bps	19200bps
69	Serial Parity	Even / Odd / No Parity	Even Parity
70	MODBUS Address	Disabled or 1 – 246	Disabled
71	Clear Alarm Log	Clear / Don't Clear	Don't Clear

7.2 Commissioning Menu Functions

7.2.1 Internal Date / Time

The date and time are used in the transmitter to run time based operations such as impedance readings and gas calibration checks. The correct date and time should be entered by pressing and holding the OPTION Δ and OPTION ∇ buttons. The date and time will change faster the longer the button is held.

7.2.2 Service Date

The service date can be used to keep a record of when a probe was changed. The Runtime timer which keeps a track of the hours and minutes that the transmitter and probe has been operating is reset when the service date is changed.

The service date and the runtime timer can be displayed as lower line items in Run Mode.

7.2.3 Number of Probes

Options: Single Probe / Dual Probe

Default: Single Probe

The 1732 transmitter can operate in single or dual probe mode. By selecting single probe, all dual probe options and alarms will be disabled and second probe options hidden from the user.

If you are using the transmitter with a single oxygen probe, setting the number of probes to 'single probe' will disable all probe 2 alarms and display items.

7.2.4 Probe 1 & 2 Type

Options: 1231 / 1234 Heated
1232 Unheated

Default: 1231 / 1234 Heated

The probe type function allows a selection between a heated probe and an unheated probe types. Heater control and alarms will be disabled if unheated probe type is selected.

7.2.5 Probe 1 & 2 Thermocouple Type

Options: K-Type / J-Type / R-Type / S-Type

Default: K-Type

The thermocouple in the Novatech 1231/1234 heated probes are always K type. 1232 unheated probes are available in R type or S type. Other thermocouple options are made available for special installations.

7.2.6 Auxiliary Thermocouple Type

Options: Disabled / K-Type / J-Type / R-Type / S-Type

Default: Disabled

When the transmitter is operating as a single probe mode, the probe 2 thermocouple input (terminals 7&8) is used as an auxiliary thermocouple input. In dual probe mode this option is unavailable.

Use of an auxiliary thermocouple allows for basic monitoring of temperature as well as enabling the calculation of combustion efficiency. The thermocouple type can be set to K, J, R or S.

7.2.7 Transmitter Output Channel 1 & 2

The 1732 transmitter has two fully configurable 4-20mA analogue outputs. The channels can be configured independently to output one of several calculated values.

The following outputs are available on channel #1:

Output	Zero	Span	Step	Min Span	Default
Linear Oxygen	0 to 99%	1 to 100%	1%	1%	0 to 10%
Linear Oxygen Average ¹	0 to 99%	1 to 100%	1%	1%	0 to 10%
Very Low Oxygen	0 to 19,990ppm	10 to 20,000ppm	10ppm	10ppm	0 to 20,000ppm
Logarithmic Oxygen	0.1% fixed	20% fixed	-	-	0.1 to 20%
Reducing Oxygen exp.	+2 to -28	0 to -30	1	2 decades	-1 to 30
Oxygen Deficiency	-10 to 0%	0 to 20%	1%	5%	-5 to 10%
Combustion Efficiency ²	0 to 80%	20 to 100%	10%	20%	0 to 100%
Combustibles %	0 to 19,000ppm	1000 to 20,000ppm	100ppm	1000ppm	0 to 20,000ppm
Max Dry CO ₂ %	0 to 10%	5 to 100%	5%	5%	0 to 100%
Probe EMF	0 to 1,400mV	100 to 1,500mV	100mV	100mV	0 to 100mV
Aux TC Temperature ²	0 to 1500C	100 to 1600°C	100°C	100°C	0 to 1300°C
No Output	-	-	-	-	-

¹ Only available in dual probe mode. ² Only available in single probe mode.

The zero and span of the selected output are set in the following two menus (Commissioning Menu functions #11 & #12 for Output 1 and Commissioning Menu functions #14 & #15 for Output Channel 2).

The units of display for Very Low Oxygen are set using the Setup Menu Function #04. See chapter 6.4.3 Oxygen Display Units

NOTE:

Regarding channel output configuration; both 4-20mA channels are separately isolated and output variables and scaling are individually configured for each channel.

In single probe mode both channel 1 and 2 have identical options, however when the analyser is configured as dual probe then channel 1 will output process variables relative to probe 1 and channel 2 will output process variables relative to probe 2.

7.2.8 Flue Pressure Units

Options: Inches WG / mm WG / kPa / PSI / Atm

Default: Inches WG

The units that the flue pressure will be displayed and scaled by.

7.2.9 Flue Pressure Input Units and Value

Options: Fixed or Variable

Default: Fixed

The 1732 Transmitter is capable of fixed or variable input pressure compensation in the calculation of oxygen from -1 Atm to +3 Atm relative to ambient. If the probe is running in a pressurised environment this value should be set to allow for accurate oxygen measurement.

If the flue pressure is constant, then select 'Fixed' in Commissioning Menu function #17 and enter the fixed value into function #18. If the pressure varies then flue pressure transducer may be needed to automatically compensate for variation. (see chapter 4.23 Connecting a Pressure Transducer). If a pressure transducer is being used, select 'Variable' in Commissioning Menu function #17 and set the range of the transducer using a zero and span value in functions #19 and #2.

7.2.10 Temperature Units

Options: Celsius or Fahrenheit

Default: Celsius

The display on the transmitter can be changed to show temperature scaled in either Celsius or Fahrenheit.

7.2.11 Calibration Freezes Outputs

Options: Enabled or Disabled

Default: Enabled

During gas calibration checks it may be required that the analogue outputs remain frozen at their last reading. When cal freezes is enabled both analogue outputs remain frozen until the entire calibration cycle has completed.

7.2.12 Solenoid 1 & 2 Operation

Options: Disabled / Calibration Check / Probe Purge / Begin Sample

Default: Disabled

The two solenoid outputs can be individually configured to perform gas calibration check, probe purge, or control when the transmitter will begin an oxygen sample. Depending on which of the three options is selected, the order of events within the solenoid operation cycle will vary.

Some of the menus between functions 22 to 28 (31 to 37) will not appear depending on what has been selected in function #20 and #21 (29 and 30).

7.2.13 Solenoid 1 & 2 Automatic / Manual

Options: Manual or Automatic

Default: Manual

When set to automatic the solenoid will perform a gas calibration, probe purge or commence a oxygen sample cycle at regular intervals as defined by the successive menu settings.

When set to manual the solenoid operation will only trigger when the corresponding button on the front panel is pressed. When set to automatic the solenoid operation cycle will commence at regular intervals as defined in the successive menus.

Additionally, when set to automatic a solenoid cycle can be manually triggered at any time by pressing the corresponding button on the front of the case. Likewise, an automatic solenoid cycle that is active can be terminated by pressing the same button again.

The Commissioning Menu functions #24 to #31 relating to Solenoid 1 will vary depending on the solenoid mode of operation selected in function #23 & #24. Likewise, the Commissioning Menu functions #33 to #40 relative to Solenoid 2 will vary depending on the solenoid mode of operation selected in function #32 & #34.

7.2.14 Solenoid 1 & 2 Start Time

Options: 00:00 to 23:45 in 15 minute increments

Default: 00:00 (midnight)

For automatic gas calibration checking, probe purging or oxygen sampling, the start time for the solenoid cycle is specified to allow precise control over the timing of not only the initial cycle, but all successive cycles which occur at regular timed intervals. Starting at this specified time, the next gas calibration, probe purge or gas sample event will occur in successive intervals from this time as defined by the solenoid frequency menu option below.

7.2.15 Solenoid 1 & 2 Frequency

Options: Keypad Only
1 to 5 Minutes in 1-minute increments
10 / 15 / 20 / 30 Minutes
1 / 2 / 3 / 4 / 6 / 8 / 12 Hours
1 to 7 Days in 1-day increments
Default: 1 Hour

This option defines the period between automatic gas calibration, probe purge or oxygen sample events. For periods less than 24 hours the period is divisible into 24 hours forcing scheduling of events to occur at the same time each day between 1 minute and 7 days.

The 'Keypad Only' option is accessible by scrolling the option below 1 minute. This option allows for pre-configured solenoid operation cycles that are only triggered manually via the keypad.

7.2.16 Solenoid 1 & 2 Duration

Options: 1 to 90 Seconds in 1 second increments
Default: 30 Seconds

This option defines the duration of time that an automatic gas calibration, probe purge or oxygen sample event takes. During this time the corresponding purge/cal solenoid is energised.

7.2.17 Solenoid 1 & 2 Post Freeze / Sample Pre-Purge

Options: None, 5 to 300 Seconds in 5 seconds increments
Default: 60 Seconds

When the solenoid is set to Calibration Check or Probe Purge, this is the duration of time the transmitter waits before resuming live readings following a gas calibration or purge event. (see also chapter 7.2.11 Calibration Freezes Outputs).

If the transmitter is configured for gas sampling, this option defines the period of time at the commencement of a gas sample between the corresponding solenoid being energised, and the gas sample commencing. During this time the state of the purge/cal solid-state relay will depend on the solenoid mode of operation; For calibration check and probe purge the solid-state relay will be de-energised, but for solenoid controlled oxygen sampling, as the pre-purge occurs at the commencement of the sample, it will be energised.

7.2.18 Oxygen Content Calibration Gas 1 & 2

Options: 0.1% to 21.0% in 0.1% increments
Default: 8.0%

When configured as a gas calibration check solenoid this value specifies the oxygen content of the calibration gas.

7.2.19 Maximum Calibration Gas 1 & 2 Positive / Negative Error

Options: 0.1% to 3.0% in 0.1% increments
Default: 0.5% (Positive Error) 0.2% (Negative Error)

Specifies the maximum positive & negative error levels used during the gas calibration check. If the difference between the specified oxygen content and the measured process gas exceed these thresholds, a gas calibration error alarm will be triggered immediately.

7.2.20 Process Alarms

The oxygen measurements are continuously monitored by the transmitter for process alarm conditions (Process alarms must be enabled in the Setup Menu function #06, see chapter 6.4.5 Process Alarms).

The limits and the alarm time delays are configurable for the Very Low Oxygen alarm, Low Oxygen alarm, High Oxygen alarm and the Oxygen Deviation alarm.

7.2.21 Alarm Relay 1, 2 and 3 Function

There are 4 user configurable alarm relays. Any of the relays can be configured to be triggered on the following alarm conditions. In addition, any of the alarm conditions that are disabled from the common alarm relay can also be configured to trigger these 3 relays. Multiple selections can be made.

Process Alarms

Oxygen 1 Low	Probe 1 Temperature Low	¹ Only available if a second oxygen probe is enabled
Oxygen 2 Low ¹	Probe 2 Temperature Low ¹	
Oxygen 1 Very Low	Calibration 1 In Progress	
Oxygen 2 Very Low ¹	Calibration 2 In Progress	
Oxygen 1 High	Purge 1 In Progress	
Oxygen 2 High ¹	Purge 2 In Progress	
Oxygen Deviation ¹	Burner Interlock Status	

7.2.22 Common Alarm Relay Function

The common alarm relay can be configured to be triggered on any of the following:

Instrument Alarms

Probe 1 Heater Fail	Output 1 Fail
Probe 2 Heater Fail ¹	Output 2 Fail
Probe 1 High Impedance	Heater 1 SSR Fail
Probe 2 High Impedance ¹	Heater 2 SSR Fail ¹
Probe 1 Thermocouple Open Circuit	Heater SSR Leakage
Probe 2 Thermocouple Open Circuit ¹	Probe 1 Filter Blocked
Aux Thermocouple Open Circuit	Probe 2 Filter Blocked ¹
Reference Air Pump Fail	Gas 1 Calibration Error
Reference Air Pump Overload	Gas 2 Calibration Error ¹
Alarm Log Fail	

¹ Are only available in dual probe mode

All of the items in this list are selected as the default setting. Any of these items can be disabled from the common alarm by pressing the ENTER button, and they will then appear on the list in the other alarm relays.

7.2.23 Accepted Alarm Relay Hold

Options: Enabled or Disabled

Default: Enabled

When an Alarm Relay is configured to trigger on a specific alarm state, the relay will remain energised while the alarm state is clear, and will de-energise when the alarm state is active. There are however two other states in which the alarm may find itself where the function of the alarm relay may depend on the installation.

An alarm that has been acknowledged via the keypad, but is still present is classed as 'accepted', while an alarm which has triggered, then the alarm state has cleared before it was acknowledged is classed as 'self-cleared'. While in the 'accepted' state, the function of the alarm relay can be altered with this setting

Alarm state	Enabled	Disabled
No alarm condition	Closed circuit	Closed circuit
New alarm	Open circuit	Open circuit
All alarms accepted	Open circuit	Closed circuit
Alarms self-cleared	Closed circuit	Closed circuit

To enable backward compatibility with the 1632 series transmitter, set this to Enabled.

7.2.24 Probe Impedance Test Options

Probe impedance testing (abbreviated to Z-Test) provides an indication of the oxygen sensor rate of response and overall health. The 1732 Oxygen Transmitter automatically checks probe impedance at fixed intervals and raises an alarm if the impedance value is above a set threshold.

Z-Test Frequency

Options: Daily, Every 2 Days, Every 4 Days, Monday, Tuesday, Wednesday, Thursday, Friday, Saturday, Sunday, Disabled, Default Settings

Default: Daily

Z-Test Start Time

Options: 00:00 to 23:45 in 15-minute increments

Default: 11:30

The time of day that the automatic impedance test is scheduled to occur

After each impedance test is completed, the next impedance test is scheduled to occur at an interval set by this menu. By setting the Z-Test Frequency to 'Default Settings' this will alter both the Z-Test frequency and Z-Test Start Time to check probe impedance daily at 11:30am.

Note, it is possible to disable automatic impedance testing by setting this menu to 'disabled'. If automatic impedance testing is disabled it is necessary to manually perform impedance tests using the local keypad at regular intervals to monitor probe health.

Z-Test Post Freeze

Options: Automatic, No Freeze, 5, 10, 15, 20, 30, 45, 60, 90, 120, 150, 180 Seconds

Default: Automatic

Following an impedance test the sensor requires a period of time to return to stable reading. This time varies greatly depending on the process and age of the probe. By default, the transmitter automatically calculates post-freeze time based on probe impedance, however this freeze time can be manually overridden using this menu.

7.2.25 Selecting the Correct Fuel

The 1732 transmitter can calculate several measurements that are based on the oxygen reading and the temperature of the process gas. These calculations also require some details about the chemical makeup of the fuel. The additional calculations are:

Oxygen deficiency	The volume of oxygen required to bring the combustion back to stoichiometry
Combustibles	This theoretical scale is equivalent to a combustibles analyser
Carbon dioxide (maximum dry)	The calculated maximum level of CO ₂ in the combustion gas
Combustion efficiency	Requires a stack thermocouple and so is only available in single probe mode

Select the required fuel in Commissioning Menu function #54 by using the OPTION buttons and then press the ENTER button. The table of values in the next 6 functions will be updated for that fuel.

7.2.26 Reference Air Pump Options

Normally the reference air is supplied from the transmitter using the internal pump. The pump will be a model MP-24 or a model CM-15. The default options are to use an Internal MP-24 pump at 2.00v.

	Function	Options
64	Reference Air Pump	External or Internal
65	Internal Pump Voltage	MP-24 select 2.00v, CM-15 select 3.5v
66	Reference Air RH%	If external is selected, set the RH level. (5% if instrument air is used)

7.2.27 Communications Port Options

The 1732 Transmitter has a serial communications port available at terminals 18 to 22. The default protocol is for RS-232 running at 19,200 baud rate with 8 bits, Even parity and 1 stop bit.

	Function	Options
67	Serial Interface	Disabled / RS-232 / RS-485 (Use RS-485 for MODBUS)
68	Serial Baud Rate	2400, 4800, 9600, 19200, 38400, 57600, 115200 (RS-232 up to 19200 only)
69	Serial Parity	Even, Odd or No Parity
70	MODBUS Address	Set the MODBUS address for this device between 1 and 246. 0 is to disable the MODBUS

7.2.28 Alarm Log Clearing

Every alarm that is instigated internally in the transmitter or as a process level is recorded in the alarm log with the activation time, accepted time and the cleared time. The last 4000 events will be recorded and then the oldest alarms will be dropped off as new ones occur. If you would like to delete the log recording use the OPTION buttons to select CLEAR and press the ENTER button. The message "Alarm Log Cleared" will be displayed.

This page has been intentionally left blank.

8. CALIBRATION MENU

This chapter describes the functions available in the Calibration Menu on the transmitter. For specific information about calibrating the transmitter see Chapter 10. Instrument Calibration.

To Access the Calibration Menu;

- Ensure the DIP switch SW1-3 on the main PCB is in the ON position
- From Run Mode, press and hold the Setup button for approximately 4 seconds until the words “Calibration Menu” appears at the bottom of the display.

When the transmitter is in the Calibration Menu the Setup Light will be on and the words “Commissioning Menu” will be shown at the bottom of the display. The transmitter will return to the Run Mode when the SETUP button is pressed again or after 60 seconds of keypad inactivity.

Changing options in the Calibration Menu is the same as the Setup Menu. see chapter 6.3 Changing Menu Options.

8.1 Function Summary Table

The following table shows a summary of Calibration Menu functions:

Menu #	Function name	Range	Default value
01	Reference Voltage 1, 50mV	40.00 to 60.00mV	47.14mV
02	Reference Voltage 2, 200mV	180.00 to 210.00mV	182.24mV
03	Reference Voltage 3, 1200mV	1150.0 to 1250.0mV	1221.8mV
04	Reference Voltage 4, 2500mV	2400.0 to 2550.0mV	2489.2mV
05	Output Channel 1, Calibration	Auto Calibrated / Manual Calibrated / Set 4mA / Set 20mA	Auto Calibrated
06	Output Channel 1, 4mA Trim	3.00 to 5.00mA	4.00mA
07	Output Channel 1, 20mA Trim	19.00 to 21.00mA	20.00mA
08	Output Channel 2, Calibration	Auto Calibrated / Manual Calibrated / Set 4mA / Set 20mA	Auto Calibrated
09	Output Channel 2, 4mA Trim	3.00 to 5.00mA	4.00mA
10	Output Channel 2, 20mA Trim	19.00 to 21.00mA	20.00mA
11	Ambient Temperature Sensor Offset	-10.0°C to 10.0°C	0.0°C
12	Low Oxygen Cal 1	80.0% to 120.0%	100.0%
13	Low Oxygen Cal 2		
14	Ref Gas Probe 1	Ambient Air, 0.1% to 25%	Ambient Air
15	Ref Gas Probe 2		
16	Transmitter Output Select	4-20mA / 0-20mA / 4-20mA over-scale limit / 0-20mA over-scale limit	4-20mA
17	Transmitter Output Limiting	Disabled / Hold 0mA / Hold 4mA / Hold 20mA	Hold 0mA
18	Mains Voltage Detection Override	Automatic / 220/240 / 110/120	Automatic
19	Mains Frequency Detection Override	Automatic / 50Hz / 60Hz	Automatic
20	Heater SSR Selection	Normal Heater1 <-> Heater2 Heaters <-> CalPurge	Normal
21	SSR Fail Protection	Enabled / Disabled	Enabled
22	Burner Temp O/Ride	Enabled / Disabled	Disabled
23	Ref Pump Cycling	Always On / Cycle Above xx°C (where xx is ranged 30-55°C)	Cycle Above 35°C
24	Dry Reference Air	Wet Air / Dry Ambient / Dry Air	Wet Air

8.2 Calibration Menu Functions

8.2.1 Reference Voltages

The calibration of the analogue inputs is based on the voltage of a temperature compensated voltage reference integrated circuit. There are 4 voltages generated from the standard reference voltage. They will vary by about 1% from one transmitter to another but can be trimmed by setting the actual voltages into Calibration Menu functions #01 to #04.

8.2.2 Output Channel 1 and 2 Calibration

Options: Auto Calibrated / Manually Calibrated
Calibrate 4mA / Calibrate 20mA

Default: Auto Calibrated

The analog 4-20mA output calibration can be set either Auto or Manual.

If Auto Calibrated is selected the transmitter will go through an output calibration cycle when the power is turned on or when the AUTO CAL button is pressed in the Setup Menu. This will divert the outputs back to the input and automatically set the 4mA and 20mA calibration.

If Manually Calibrated is selected, then the 4mA and 20mA calibration must be set in the next two functions. For the full explanation see chapter 10.1.2 Calibration of the Outputs.

8.2.3 Ambient Temperature Calibration

The ambient temperature measurement is used as the cold junction temperature for the thermocouple measurements. Use an independent temperature sensor to measure the temperature inside the transmitter case near the screw terminal #1. Enter this temperature into the calibration function 11 by using the OPTION buttons and then the ENTER button.

8.2.4 Low Oxygen Calibration

Options: 80.0% to 120.0% in 0.1% increments

Default: 100.0%

The low oxygen calibration factors can be used to fine tune the oxygen calculation at low oxygen readings. It will not affect the measurement at 20.9%. They are included to allow oxygen probes made by other manufacturers to be used on a Novatech transmitter. The default is 100% but can be set to between 80 and 120%.

8.2.5 Reference Air Probe 1 and Probe 2

Options: Ambient Air or 0.1% to 25% in 0.1% increments

Default: Ambient Air

The oxygen sensor measures oxygen concentration in the process gas relative to the oxygen concentration in the gas exposed to the reference side of the sensor. In most installations the reference gas used is atmospheric air, which has a (dry) oxygen concentration of 20.95%. In some specialised cases the reference gas may be provided by other means such as gas generators or cylinders containing a fixed oxygen content.

Warning: Adjusting this number will affect the calculation of process gas oxygen content. This setting should be left as 'Ambient Air' air unless bottled gas with a certified oxygen content is being used for reference air.

8.2.6 Transmitter Output Scale

Options: 0-20mA / 4-20mA
0-20mA over-scale limit / 4-20mA over-scale limit

Default: 4-20mA

The transmitter can drive the outputs to ~24mA for loads <700 ohms and by default the transmitter will allow the transmitter outputs to transmit out of range (below 4mA or above 20mA) if the process variable scaling is also out of range. To prevent the transmitter outputs from retransmitting out of range set this option to either '0-20mA over-scale limit' or '4-20mA over-scale limit'

8.2.7 Transmitter Output Limiting

Options: Hold 0mA (for 0-20mA Transmitter Output Scaling)
Hold 4mA (for 4-20mA Transmitter Output Scaling)
Hold 20mA

Default: Hold 0mA / Hold 4mA

The oxygen probes used in the calculation of all process variables cannot provide an accurate measurement for oxygen until they reach their operating temperature of 650°C (1200°F). If an oxygen probe is below operating temperature, or if the probe thermocouple has been detected as open circuit then the transmitter is unable to calculate a valid reading for any process variable that uses oxygen as part of its formula. While the transmitter has no valid process variable the analog outputs are held at this nominated level until a valid reading can be made. The default is to set the output to 20mA.

8.2.8 Mains Voltage Detection

Options: Automatic / 220-240V / 110-127V

Default: Automatic

Options: Automatic / 50Hz / 60Hz

Default: Automatic

The default setting for the 1732 Transmitter is that it will automatically detect the mains voltage and frequency to correctly power the probe heaters. If there is any uncertainty in this detection system, the automatic voltage detection can be overridden and manually set.

8.2.9 Heater SSR Fault Correction

Options: Normal / Heater1 <-> Heater2 / Heaters <-> CalPurge

Default: Normal

In the event of one of the heater solid state relays (SSR) failing in single probe mode, this option can be used to swap the functions of the various powered relay outputs.

Warning, this option requires altering the wiring inside the transmitter. It is not recommended that you make changes to this function unless you are working around a specific hardware fault.

Refer to the table below for details:

Mode	Heater 1 Solenoid	Heater 2 Solenoid	Cal / Purge 1 Sol	Cal / Purge 2 Sol
Normal	Heater 1	Heater 2	Cal / Purge 1	Cal / Purge 2
Heater1 <-> Heater2	Heater 2	Heater 1	Cal / Purge 1	Cal / Purge 2
Heaters <-> CalPurge	Cal / Purge 1	Cal / Purge 2	Heater 1	Heater 2

8.2.10 SSR Fail Protection

Options: Enabled or Disabled

Default: Enabled

The transmitter continuously monitors the high voltage outputs on the solid-state relays that power the probe and purge/cal solenoids. If it detects that any solenoids are not switching off correctly then it mechanically isolates all high voltage outputs to protect the instrument. This feature can be switched off by setting the SSR fail protection to disabled.

Note: It is recommended that you leave this enabled unless you are experiencing problems with the leakage detection system.

8.2.11 Burner Temp Override

Options: Disabled, or Enabled

Default: Disabled

The mains power to the two probe heaters and purge/cal solenoids is switched through the electromechanical 'burner' relay. In addition to being used to disable the probe heaters as part of the burner interlock safety system, this relay can also be de-energised by the 1735 transmitter to protect a probe from burning out in the event of a failure in the probe temperature controller.

In normal operation the burner interlock is de-energised if any heated probe exceeds 735°C (1355°F) as this may indicate an electronic fault in the transmitter temperature controller or feedback loop. In certain applications where heated probes are used in a process that exceeds 735°C, to use the purge/cal solenoids at temperatures above 735°C this override option must be set to enabled.

WARNING: by enabling the burner temperature override, the operator acknowledges that in the unlikely event of a probe heater solid-state relay short-circuit, the normal temperature protection will be disabled resulting in the probe heater burning out.

8.2.12 Ref Pump Cycling

Options: Always On, or Cycle Above 30°C to 55°C in 5°C increments

Default: Cycle Above 35°C

The internal reference air pump is used to move a small volume of atmospheric air to the reference side of the oxygen sensor to allow for the continuous accurate measurement of oxygen concentration in the process gas relative to ambient. If an oxygen probe is used without a reference air pump then the oxygen on the reference side of the sensor will 'stagnate' and result in drift in the EMF output of the sensor.

The reference air pump is a small mechanical diaphragm pump located inside the transmitter case. As the temperature inside the case heats up, the expected lifespan of the pump will reduce. In order to maximise the life of the pump the transmitter can cycle the reference air pump to reduce its overall use.

Once the internal case temperature exceeds the pump cycle threshold, the reference air pump will run for 30 seconds on, then 30 seconds off. This is enough to prevent the atmospheric air on the reference side of the sensor from stagnating.

8.2.13 Dry Reference Air

Options: Wet Air / Dry Ambient / Dry Air

Default: Wet Air

The oxygen probe measures process gas oxygen concentration relative to the oxygen concentration of the reference side of the sensor which is exposed to atmospheric air. Atmospheric air will contain 20.95% oxygen by volume in dry air, however the presence of humidity will displace this dry air reducing the oxygen content proportionally. It is normal for a probe running with ambient air on both the reference and process side of the sensor to read oxygen concentration slightly lower than 20.95%.

Some operators prefer to assume that atmospheric air is 'dry air', and therefore prefer to see an open-air reading of 20.95%. In this case, we have several options;

- **Wet Air** Always use the humidity compensated 'wet air' as the reference oxygen concentration when calculating process oxygen. This is the default, and preferred option.
- **Dry Ambient** Use humidity *uncompensated* 'dry air' as the reference oxygen concentration for calculating process oxygen in the range $20.95 \pm 1\%$, but use 'wet air' when the process oxygen deviation is $> \pm 1\%$ from atmospheric oxygen. This allows for accurate readings at process level as well as seeing 20.95% in ambient air.
- **Dry Air** Always use humidity *uncompensated* 'dry air' as the reference oxygen concentration when calculating process oxygen.

9. ALARMS

The 1732 Oxygen Transmitter has 4 alarm relays, a built-in alarm annunciator and an alarm log. When an alarm occurs, the Alarm Light will flash. To find out what the alarm is, press the ALARM Δ button.

When the ALARM Δ button has been pressed, the transmitter goes into the Alarm Display Mode. In this mode some of the buttons take on a different function.

Button text	Run Mode	Alarm Mode
SETUP / RUN	*	Return to Run Mode
DISPLAY / FUNCTION Δ	*	Next alarm
DISPLAY / FUNCTION ∇	*	Last alarm
ALARM / OPTION Δ	Enter Alarm Display Mode	Alarm activated time
ALARM / OPTION ∇	Enter Alarm Log Mode	Alarm acknowledged time
ALARM ACCEPT / ENTER	*	Acknowledge alarm
GAS 1 PURGE 1 / SENS IMP	*	*
GAS 2 PURGE 2 / AUTO CAL	*	*

* This button is not used in the Alarm Display Mode

The common alarm relay is intended to monitor faults within the transmitter and the probe. The other three alarm relays relate to the process gas. The actions of all four relays can be configured using the Commissioning Menu.

If one of the alarm events is removed from the common alarm using Commissioning Menu function #49, then this alarm event can be programmed for one of the other 3 alarm relays.

When the Alarm Mode has been entered, the Setup Light flashes once a second. The transmitter will return to Run Mode if the SETUP / RUN button is pressed a second time, or after 60 seconds of keypad inactivity.

All relays have fail-safe alarm contacts. That is –

When the transmitter is powered off the contacts are open circuit

When the transmitter is powered on but there are no alarms the contacts will be closed

When there is a current unaccepted alarm event the contacts will be open circuit

When there is a current accepted alarm event the state of the contacts will depend on the selection in the Commissioning Menu #53. See chapter 7.2.23 Accepted Alarm Relay Hold.

All alarms drive the alarm light on the front door.

The light will be off if there are no alarms current

The light will flash if there is a current alarm that has not been acknowledged

The light will be on steady if there are current alarm(s) that have not been cleared

The light will flash faster as more alarms occur

9.1 Checking and Accepting an Alarm

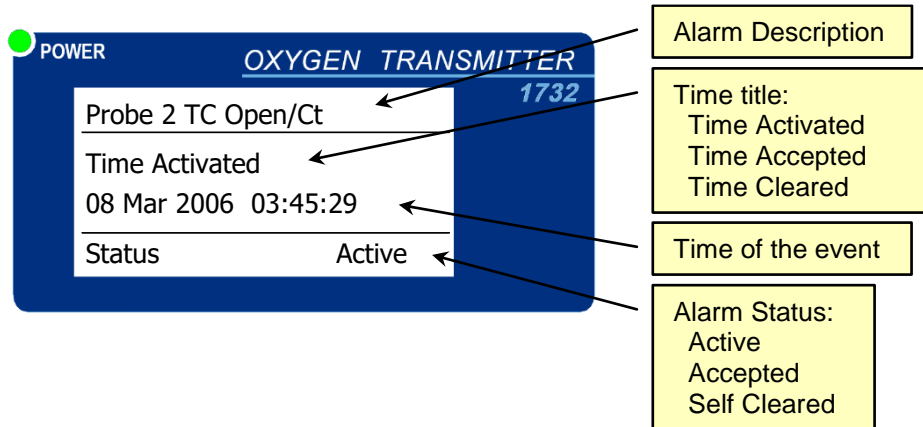

When a new alarm occurs, either a process alarm or an alarm that will appear in the common alarm list, the Alarm Light will flash quickly. The more active alarms there are, the faster the light will flash.

To check the cause of the alarm –

1. Press the ALARM Δ button. This will put the transmitter into the current alarm mode. The Setup Light will flash.
2. The alarm screen will appear displaying the cause of the alarm on the top line.
3. Press the ALARM ACCEPT button to accept the alarm.
4. Press the OPTION Δ button to see the next active alarm or the OPTION ∇ button to see the previous active alarm.
5. When all the new alarms have been ACCEPTED the Alarm Light will stop flashing.
6. Accept each alarm and then press the SETUP / RUN button to return to the Run Mode

9.1.1 Current Alarms

To view the alarms that are still current press the ALARM Δ button from the Run Mode and then use the ALARM Δ and ALARM ∇ buttons to view all alarms. Use the DISPLAY Δ and DISPLAY ∇ buttons to view the Time Activated and the Time Accepted of each alarm.

9.1.2 Alarm Log

The alarm log keeps a record of the alarm events after the cause of the alarm has been cleared. It will hold a record of up to 4000 alarm events and will be retained even with the transmitter power off.

To view all the alarms that have occurred in the alarm log press the ALARM ∇ button from the Run Mode. The display will look like this:

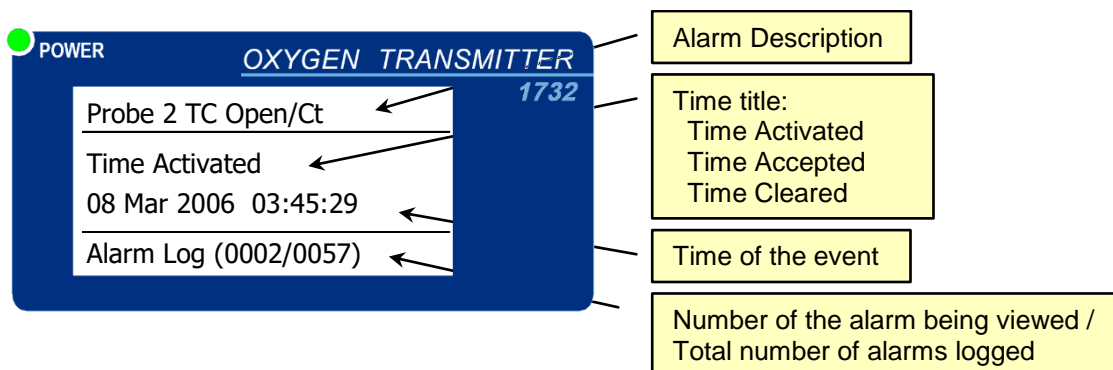

Use the OPTION Δ and OPTION ∇ to scroll through the alarm events that have been saved in the alarm log. The alarm event will be transferred to the alarm log when the alarm has been cleared.

The alarms are stored in the alarm log in chronological order. However, it may be seen that the current alarm number will skip some numbers. These numbers have been reserved for alarm events that are still current. When the alarm cause has been removed, these alarm events will be transferred to the alarm log.

9.2 Hardware Alarms

The cause of events that trigger the common alarms are described below, along with some suggestions on what might be the appropriate response to these alarms. If the alarm cannot be resolved using the directions below then the fault may be with the transmitter itself. If you believe this is the case, please contact your supplier to discuss further testing or repair options.

It is assumed that an appropriately qualified technician will carry out the testing, the probes, transmitters and cabling may contain active mains power. Please disconnect all wiring to the probe before performing any electrical tests.

1. Probe 1 Heater Fail

2. Probe 2 Heater Fail

Alarm Trigger: This alarm indicates that the heated oxygen probe has failed to reach the minimum operational temperature of 650°C (1200°F) within 20 minutes of the heater turning on.

A heated oxygen probe should reach its operating temperature of 720°C in less than 20 minutes from the time it is switched on. If it does not reach this temperature within this time, this alarm will be triggered. The most likely causes of this fault are a damaged heater or heater insulation. Sometimes this alarm can also be triggered if the probe is being cooled down by excessive airflow across the sensor.

Response to Alarm: Use a digital multimeter to test the probe heater and confirm whether it is open-circuit. Check the fuses FS2 and FS3 inside the transmitter and confirm neither are open-circuit. Test to see whether there is significant cooling to the probe caused by the process which may result in the probe temperature dipping below 650°C (1200°F).

3. Probe 1 High Impedance

4. Probe 2 High Impedance

Alarm Trigger: Oxygen probe electrode failure. The transmitter monitors the health of the oxygen sensor by periodically testing the sensor's internal impedance. The impedance will naturally vary from ~0.2kΩ when new and settle at 2kΩ - 5kΩ during its operational lifetime. As the sensor reaches the end of its operational lifespan the impedance will begin to increase more rapidly and once it exceeds 8kΩ the response rate of the sensor will be too slow for use.

Response to Alarm: Replace the probe. Contact your local distributor to discuss refurbishment options for your old probe.

5. Probe 1 TC Open Circuit

6. Probe 2 TC Open Circuit

Alarm Trigger: The Probe thermocouple is reading open-circuit.

NOTE: For heated probes, the heater is switched off when the thermocouple is open circuit.

Response to Alarm: Use a digital multimeter to test the thermocouple contacts on the probe and confirm whether it is open-circuit. Check any terminations for the thermocouple wires from the cable inside the transmitter. Check for any physical damage to the probe cable.

7. Aux TC Open Circuit

Alarm Trigger: The aux thermocouple is reading open-circuit.

This alarm will only trigger for configurations where the Aux TC is enabled. See chapter 7.2.6 Auxiliary Thermocouple Type

Response to Alarm: Use a digital multimeter to test the dryer TC and confirm whether it is open-circuit. Check any terminations for the Dryer TC cabling inside the transmitter and at any other termination points. Check for any physical damage to the dryer TC cable.

8. Ref Air Pump Fail

Alarm Trigger: The reference air pump in the transmitter has failed. The transmitter has an internal reference air pump for supplying ambient air to the reference side of the oxygen probe. The transmitter monitors the current being drawn by this pump to detect for failures.

This alarm corresponds to the current being drawn by the pump being abnormally low, indicating the pump is no longer present.

Response to Alarm: Check the wiring on the pump for any broken wires. Check the connector CN8 to the reference pump is fully inserted. Replace the reference air pump.

9. Reference Air Pump Overload

Alarm Trigger: Refer to the first paragraph of the alarm trigger description for 'Ref Air Pump Fail' above.

This alarm corresponds to the current being drawn by the pump being abnormally high. The pump is disabled to protect the drive circuitry from damage.

Response to Alarm: Check the pump for any signs of physical damage. Replace the reference air pump.

10. BBRAM Fail

Alarm Trigger: The BBRAM is an internal component that maintains the date and time. If this device fails then the device loses its ability to accurately set and maintain time. This will affect time-related functions such as automatic purges which will no longer trigger at the set time.

Response to Alarm: Contact your supplier for replacement options.

11. Alarm Log Fail

Alarm Trigger: The internal memory device responsible for storing both the device calibration and alarm log has failed. If this occurs, then the device will run using default settings.

Response to Alarm: Contact your supplier to arrange for the device to be repaired.

12. ADC Calibration Fail

Alarm Trigger: The analog to digital converter has been found to fall outside the normal calibration specifications. In this case the probe heaters will automatically be turned off and the device will be unable to read inputs or re-transmit calculated process variables.

Response to Alarm: Contact your supplier to arrange for the device to be repaired.

13. Output 1 Failure

14. Output 2 Failure

Alarm Trigger: The digital to analogue and voltage isolator circuit has been found to fall outside the normal calibration specifications. This check is only performed when the AUTO CAL button is pressed. See chapter 10.1.2 Calibration of the Outputs.

Response to Alarm: If you are not using both outputs simultaneously you may be able to disable the failed output and use the second output instead. Check for any loop powered/active receivers or diagnostics devices that may have caused the failure. Contact your supplier to arrange for the device to be repaired.

15. Heater 1 SSR Failure

16. Heater 2 SSR Failure

Alarm Trigger: One of the heater power control devices (SSR) has been found to have failed.

Response to Alarm: See chapter 8.2.9 Heater SSR Fault Correction.

17. Heater SSR Leakage

Alarm Trigger: One of the heater power control devices (SSR) has been found to have failed, but the transmitter cannot determine which one or ones have failed.

Response to Alarm: See chapter 8.2.9 Heater SSR Fault Correction.

18. Probe 1 Filter Blocked

19. Probe 2 Filter Blocked

Alarm Trigger: The alarm is caused by a blocked probe filter. This test is only performed when automatic purging of the probe is selected. See chapter 11. This alarm will not reset until the next purge cycle. The cycle can be initiated manually or automatically.

Response to Alarm: Check the probe filter. If the purge system does not require an alarm this can be disabled by linking across terminals 16 & 17 on the main board.

20. Gas 1 Calibration Error

21. Gas 2 Calibration Error

Alarm Trigger: At the end of an automatic gas calibration check cycle the oxygen reading was outside the values set in the Commissioning Menu #26 to 28 (#35 to 37). This alarm will not reset until the next calibration check cycle. The cycle can be initiated manually or automatically.

Response to Alarm: Check the gas calibration system for air leaks, certified gas concentration and flow rates.

9.3 Process Related Alarms

The alarm relays 1, 2 and 3 are often used to transmit a process gas related alarm event. Any or all of the following functions can be selected for each relay.

The alarm thresholds and delay times for each process alarm are set in the Commissioning Menu.

NOTE: The process alarms will only be activated if they are enabled in the Setup Menu function #06. See chapter 6.4.5 Process Alarms.

22. Oxygen 1 Very Low

23. Oxygen 2 Very Low

The measured oxygen level on the indicated probe has been below the trip level shown in Commissioning Menu function #41 for longer than the delay time shown in function #42.

24. Oxygen 1 Low

25. Oxygen 2 Low

The measured oxygen level on the indicated probe has been below the trip level shown in Commissioning Menu function #43 for longer than the delay time shown in function #44.

26. Oxygen 1 High

27. Oxygen 2 High

The measured oxygen level on the indicated probe has been above the trip level shown in Commissioning Menu function #45 for longer than the delay time shown in function #46.

28. Oxygen Deviation

The difference between the oxygen level measured on probe #1 and the oxygen level measured on probe #2 is greater than the trip level shown in Commissioning Menu function #47 for longer than the delay time shown in function #48.

9.4 Status Alarms

Status alarms are used to transmit important information via the programmable alarm relays. They will trigger even when process alarms are disabled in the Setup Menu.

29. Probe 1 Temperature Low

30. Probe 2 Temperature Low

The probe temperature is under 650°C (1200°F). The probe cannot be used to calculate oxygen reading is therefore invalid. If the probe heater has been on for more than 20 minutes and the temperature is less than 650°C (1200°F) a 'Probe # Heater Fail' alarm will occur.

NOTE: The 'Probe # Temperature Low' relay function is used with unheated probes to indicate oxygen reading is invalid (the probe is below 650°C / 1200°F), in case the process temperature falls below this level. With heated probes this relay will be de-energised while the probe is heating up from ambient, making the contacts open circuit.

31. Cal 1 in Progress

32. Cal 2 in Progress

A calibration check or oxygen sample is in progress, triggered either in automatic mode or manually via the keypad.

33. Purge 1 in Progress

34. Purge 2 in Progress

A probe purge is in progress, triggered either in automatic mode or manually via the keypad.

9.5 Alarm Relay Options

The three process alarm relays (relays 1 to 3) are user defined. The relay action will depend on the selections made in the Commissioning Menu functions #49 to #52.

The relay contacts are all designed to be “Fail Safe”. That is, they are;

- open when the transmitter power is off
- closed when the transmitter is powered on and there is NOT an alarm condition
- open when an alarm occurs

The contact will close circuit again (relay energised) when the process alarm condition is acknowledged.

Choose to have the relays react to any or all of the following alarm or information status –

Oxygen on probe 1 Low	Process Alarm
Oxygen on probe 2 Low	Process Alarm
Oxygen on probe 1 Very Low	Process Alarm
Oxygen on probe 2 Very Low	Process Alarm
Oxygen on probe 1 High	Process Alarm
Oxygen on probe 2 High	Process Alarm
Oxygen Deviation High	Process Alarm
Probe 1 Temperature Low	Information
Probe 2 Temperature Low	Information
Calibration check on probe 1 in Progress	Information
Calibration check on probe 2 in Progress	Information
Purge on probe 1 in Progress	Information
Purge on probe 2 in Progress	Information
Burner Interlock Status	Information

Burner Interlock Status will indicate whether the Burner Interlock on terminals 10 & 11 are connected. If selected as an alarm relay option, when the relay burner interlock is open-circuit then this will cause the alarm relay to de-energise.

In addition to the above process alarms that can activate the process alarm relays, any of the common alarm relay events that have been taken off the common alarm list in Commissioning Menu function #52 will appear on the process alarm relay lists in function #49 to #51.

10.1 Calibration Summary

The 1732 Oxygen transmitter has a self-calibration and diagnostic system built into the hardware and software. Once the reference voltages have been set into memory the self-calibration system maintains the calibration of the transmitter. An automatic update of the zero and span is done every minute.

The 4-20mA outputs can be automatically calibrated with the press of the AUTO CAL button or manually fine-tuned.

One entry for each probe offset is required to optimise the calibration of the oxygen measurement although an automatic system calibration check can be programmed into the transmitter using certified gasses.

10.1.1 Calibration of the Inputs

The calibration of the analogue inputs is based on the voltage of a temperature compensated voltage reference integrated circuit. There are 4 voltages generated from the standard reference voltage. They will vary by about 1% from one transmitter to another but can be trimmed by setting the actual voltages into Calibration Menu functions #01 to #04.

The calibration should be done 30 minutes or more after the instrument has been on, approximately once every year. The calibration constants are retained in battery backed memory unless a 'COLD START' is performed. See Chapter 10.2 Cold Start

Connect a 3 1/2 digit multimeter negative lead to the test point marked 'COM' in the centre of the 1730-1 PCB (labelled 'V-REFS'). Measure the four voltages on the test point marked 1 to 4 with the positive lead of the multimeter. Enter the measured values in the CALIBRATION menu functions #1 to 4. Whenever new values are entered, the D/A Section should be re-calibrated. See chapter 10.1.2 Calibration of the Outputs.

10.1.2 Calibration of the Outputs

The easiest way to calibrate the outputs is to select 'Auto Calibrated' in Calibration Menu functions #5 and 8. If this is selected the outputs will be directed away from the output terminals and back into an analogue input of the transmitter. The outputs are then tested and a zero and span calibration factor is recorded.

If a more accurate calibration is required select 'Manually Calibrated' in Calibration Menu functions #5 and 8. This will inhibit the automatic calibration system overwriting the calibration factors. However, the zero and span factors will need to be manually set. To set the calibration factors use the following steps for each output:

1. Select Calibration Menu function #05 (function #08 for Output 2), press the OPTION Δ button to set the option to 'Calibrate 4mA'. Press the ENTER button.
2. Press the FUNCTION Δ button to navigate to Calibration Menu function #06 (function #09 for Output 2), set this value 4.00mA using the OPTION Δ / OPTION ∇ buttons. Press the ENTER button.
3. Measure the actual output current with a digital multimeter.
4. Use the OPTION Δ / OPTION ∇ buttons to adjust the value on the display to match the reading on the digital multimeter. Press ENTER to save changes.
5. The output on the digital multimeter should now read 4.00mA. If desired, this value can be fine-tuned until exactly 4.00mA is read on the digital multimeter. Remember to press the ENTER button after each adjustment to the calibration
6. Press the FUNCTION ∇ to navigate back to Calibration Menu function #5 and press the OPTION Δ button to set the option to 'Calibrate 20mA'. Press the ENTER button.
7. Press the FUNCTION Δ button to navigate to Calibration Menu function #07 (function #10 for Output 2), set this value to 20.00mA using the OPTION Δ / OPTION ∇ buttons. Press the ENTER button
8. Measure the actual output current with a digital multimeter.
9. Use the OPTION Δ / OPTION ∇ buttons to adjust the value on the display to match the reading on the digital multimeter. Press ENTER to save changes.
10. The output on the digital multimeter should now read 20.00mA. Like before, the value can be fine-tuned as required.
11. Press the FUNCTION ∇ button to navigate back to Calibration Menu function #05 and press the OPTION Δ button twice to select 'Manually Calibrated'. Press the ENTER button.

10.1.3 Probe Calibration

There is only one calibration factor for the calibration of the oxygen probe. This is the sensor offset, and it is written on a tag attached to every probe.

Use the FUNCTION buttons to navigate to Setup Menu function #01 (or Setup Menu function #02 for probe 2) and then use the OPTION buttons to set the value to the value written on the tag. If in doubt the best option is to set the offset to 0.0mV as this will only produce an error of around 0.1% oxygen in a combustion application for a 1mV error in the offset value.

For information on checking the probe and transmitter system with a certified gas see chapter 11. Gas Calibration Check and Purge.

10.2 Cold Start

The purpose of the Cold Start function is to return all of the configuration on the transmitter back to the factory default values. There are several reasons why a Cold Start may be necessary

1. After a firmware upgrade, if the update requires changes to the menu functions then the transmitter will automatically perform a Cold Start.
2. The transmitter will automatically force a Cold Start when the power is turned on and the configuration / calibration factors are found to be corrupted. The device configuration and device calibration are stored in separate blocks of memory and the device can detect corruption and factory reset one or both parts as necessary.
3. A Cold Start can be manually performed if the operator wants to reset the transmitter back to the default factory configuration. See chapter 10.2.1; Forcing a Cold Start.
4. Resetting the calibration factors back to the default values. See chapter 10.2.2; Resetting the Calibration Factors.

10.2.1 Forcing a Cold Start

The cold start can be initiated by following these steps:

1. Turn the transmitter power off.
2. Use a fine point or screw driver to set the DIP switch SW1-1 on the 1730 main PCB to ON. The switch is at the bottom of the 1730-1 PCB, accessible through the window in the shield.
3. Turn the transmitter back on.
4. You will be prompted to select 'Reset' or 'Cancel' to the prompt 'Reset Calibration Data?'. Press the DISPLAY Δ button to reset the calibration factors and the configuration data or the ALARM Δ button to only reset the configuration of the transmitter.
5. Turn off the Cold Start switch when prompted by 'Turn off C/Start Switch'.

If the calibration factors have been reset, follow the instructions in chapter 10.1 to recalibrate the transmitter. If only the configuration has been reset it is also important to check items that will affect the transmitter outputs, number of probes, the serial communications, the solenoid configuration and other items.

10.2.2 Resetting the Calibration Factors

If it is required to reset the calibration factors, follow the instructions in the previous section and select 'Reset' when prompted to 'Reset Calibration Data?'.

11. GAS CALIBRATION CHECK AND PURGE

The Novatech oxygen sensor that is used in the Novatech oxygen probe is extremely predictable, stable and reliable. For this reason, the calibration of a Novatech oxygen system does not require the use of calibration gases for periodic recalibration. All Novatech oxygen probes do include a gas port that allows certified gasses to be directed into the probe for calibration checking or for purging filters while the probe is still installed in-situ. This chapter describes the operation of this gas checking system.

The 1732 has a timer and solenoid driving system that can be configured to admit a certified calibration gas into the probe or an air supply to purge the probe filters through the gas connection. Both the calibration gas and the filter purge gas must be piped to the port on the probe labelled "CAL".

There are two solenoids drivers in the 1732 transmitter. They can be used for any combinations of gas checking and probe filter purging. The only limitation is that if the transmitter is in dual probe mode, then solenoid #1 must be wired and plumbed to the probe #1 and solenoid #2 must be wired and plumbed to probe #2.

The transmitter can also be configured to be in a MANUAL or AUTOMATIC purge and gas check mode.

Menu	Description	Options			
23 (32)	Solenoid 1 (2) Operation	Disabled / Calibration Check / Probe Purge / Begin Sample	√	√	√
24 (33)	Solenoid 1 (2) Auto / Manual	Automatic / Manual	√	√	√
25 (34)	Solenoid 1 (2) Start Time	00:00 to 23:45		√	√
26 (35)	Solenoid 1 (2) Period	1 hour – 7 days		√	√
27 (36)	Solenoid 1 (2) Duration	1 – 90 seconds		√	√
28 (37)	Solenoid 1 (2) Post Freeze	0 – 300 seconds		√	√
29 (38)	Oxygen Content Cal Gas 1 (2)	0.1 – 20.9%			√
30 (39)	Max Cal Gas 1 (2) Positive Error	0.1% to 3.0%			√
31 (40)	Max Cal Gas 1 (2) Negative Error	0.1% to 3.0%			√

Available if 'Solenoid Operation' is set to either 'Calibration Gas' or 'Purge' ↗

Available if 'Solenoid Operation' is set to 'Purge' and 'Automatic' ↗

Available if 'Solenoid Operation' is set to 'Calibration Gas' and 'Automatic' ↗

11.1 Probe Purge

For processes that have particulate present in the gas stream, probe filters are necessary and should be back-purged with sufficient frequency to avoid blocked filters.

Select 'Purge' in Commissioning Menu function #23 (32) and 'Automatic' in function #24 (33) and then set the times in function #25 (34) to #28 (37). The outputs can be frozen during purging if selected in Commissioning Menu function #22.

A flow switch can be wired to terminals 16 and 17. If the flow is not sufficient at the end of the purge cycle to close the contacts of the flow switch a 'Probe 1 (2) Filter Blocked' alarm is generated. If a flow switch is not being used a short circuit should be placed across terminals 16 and 17 to suppress the 'Probe 1 (2) Filter Blocked' alarm.

11.2 Calibration Gas Check

If it is required to automatically check the oxygen probe and transmitter on line, select 'Calibration Check' in function #23 (32) and 'Automatic' in function #24 (33) and then set the times in function #25 (34) to #28 (37) and the gas levels in function #29 (38) to 31 (40).

If the transmitter measurement does not fall within the limits set in function #30 (39) to 31 (40) a 'Gas1 (2) Calibration Error' alarm will be generated.

If the transmitter has 'Automatic' selected in function #24 (33) and one of the GAS/PURGE button is pressed in Run Mode, the automatic cycle will be started and the alarms will be checked. The cycle can be stopped at any time by pressing the same button during the cycle.

11.3 Solenoid Control of Oxygen Sampling

The 1732 Oxygen Transmitter can be commissioned so that oxygen is only being sampled when a solenoid valve is opened allowing process gas to enter the oxygen sensor. The transmitter itself controls this gas solenoid using one of the two cal/purge solid-state relays to automatically open and close a solenoid valve at regular intervals. During each sample the local display of oxygen as well as any analog outputs and process alarms related to oxygen will be updated. In between samples these items will remain frozen at the level or state last seen during sampling.

To enable Solenoid Control of Oxygen Sampling, refer to chapter 7.2.12 Solenoid 1 & 2 Operation

An oxygen sample commences either at a time scheduled in the Commissioning Menu, or by pressing the associated purge/cal button on the front panel of the analyser.

During an oxygen sample, the order of events is as follows;

1. The purge/cal solenoid is energised.
2. The transmitter commences pre-sample purging for the time period defined in the Commissioning Menu. During this time the local display and outputs remain frozen, the indicator next to the associated button on the front panel of the transmitter will flash, and the local display will show a countdown timer until the end of the pre-purge period;

Oxygen 15.34%	
Purging 00:30	
Probe 1 Temp 720.3 C	
B	14:20:36

3. At the end of the pre-purge period the transmitter will begin sampling oxygen for the time period defined in the Commissioning Menu. During this time the local display of oxygen, analog outputs and process alarm states related to oxygen will be updated continuously. The local display will show a countdown timer until the end of the sample period.
4. At the end of the sample period the purge/cal solenoid is de-energised, the local display of oxygen and all associated outputs are frozen until the commencement of the next sample.

A sample can be terminated at any time by pressing the associated purge/cal button on the front panel of the transmitter.

If the transmitter is configured for manual only solenoid control of oxygen sampling, the solenoid will energise and reading of oxygen will only occur when the associated purge/cal button is depressed, and will freeze again when released. This option is included to assist with testing during commissioning as it does not provide any pre-sample purging or automatic sampling.

Monitoring the Status of Oxygen Sampling via Relay Outputs

The 1732 Oxygen Transmitter has four programmable alarm relays that can be configured to indicate the status of any of the hardware or process related alarms, as well as notify of the status of various actions including solenoid controlled oxygen sampling. At the beginning of the oxygen sample when the purge/cal solid-state relay is energised, the internal status 'Cal x In Progress' (where x indicates probe 1 or probe 2 accordingly) is set. Using the alarm relay options in the Commissioning Menu, this status can be assigned to one of the programmable alarm relays, which will then de-energise during each sample to indicate that it is currently in progress.

See chapter 9.4 Status Alarms for information on how to program the alarm relays.

12. SOFTWARE UPGRADES

The firmware for the 1730 series transmitters is programmed directly into the microprocessor during manufacture. It can be upgraded to a newer version using the 'firmware update socket' on the main PCB.

If an upgrade is to be made to the software it will be supplied in a 32 pin EEPROM IC type 29F010B. To do the upgrade, use the following steps:

1. Turn the power off to the transmitter using the power switch on the board
2. Remove the hose from the reference air pump (if fitted)
3. Unplug the reference air DC power lead (if fitted)
4. Undo the two M4 screws at the top and bottom of the main shield
5. Remove the earth screw from the main shield on the right hand side of the cabinet
6. Lift out the main shield around the cable glands
7. If the socket has the quick release ejectors, fold out the two wings of the blue socket labelled "FIRMWARE UPDATE SOCKET". Plug the 29F010B into the socket.

WARNING: Be very careful not to bend any of the pins of the EEPROM. If the EEPROM does not have all the pins correctly plugged into the socket during upgrade the EEPROM may be damaged and the upgrade process will not work.
Note also the direction of the EEPROM. Pin 1 is identified by a small dot on the EEPROM. This dot **MUST** be oriented in the top right hand corner of the socket as indicated by the arrow on the board and the diagram.

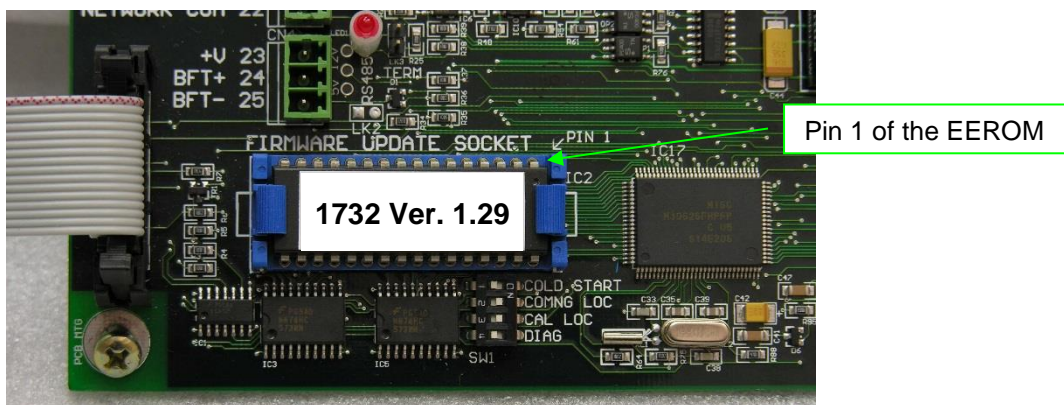

8. While the power is still turned OFF, press and hold the DISPLAY ▽ and the ALARM LOG ▽ buttons. Turn on the analyser holding down the two buttons.
9. If the message "Invalid EEPROM, Unable to Upgrade" is displayed, turn the power off again and check the pins of the EEPROM and that it was in the correct direction.
10. If the display looks like the following image, press the DISPLAY ▲ button to load the upgrade software

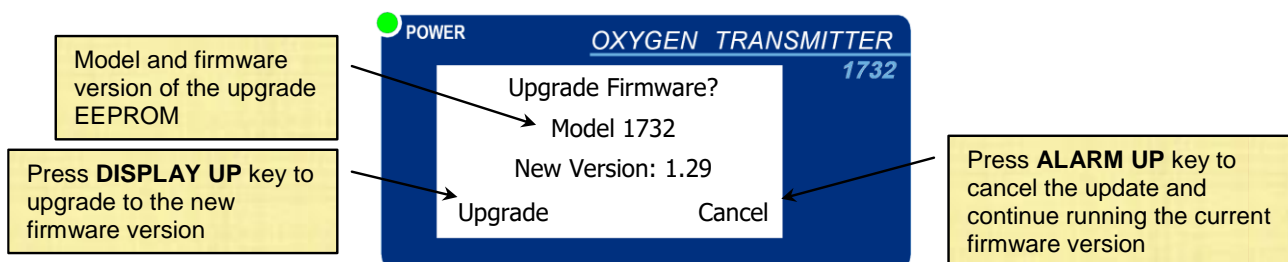

NOTE: While the firmware is being upgraded it is essential that the power is not turned off otherwise the programme will be corrupted and will not be recoverable.

11. When the transmitter has upgraded the firmware it will start up the normal initialisation. The version of the firmware is shown on the start-up screen.
12. Turn the transmitter power off.
13. Unplug the EEPROM by pressing out the wings of the blue upgrade socket. Keep the EEPROM in a safe place. The same EEPROM can be used to upgrade any number of transmitters as required.
14. Replace the main shield and secure it with the three screws.
15. Reconnect the reference air pump hose and plug (if fitted).
16. Turn the power back on.

NOTE: The transmitter may perform an automatic COLD START after the upgrade. The words 'Cold Start' will be shown on the display in step 14 if the cold start has been performed. The calibration will NOT be changed but the configuration may have been changed.

13. TROUBLESHOOTING

The Novatech 1732 Oxygen Transmitter has proved an extremely reliable instrument. The troubleshooting guide here is based on an analysis of the potential problem that may occur after many years of operation in the field. A current list of problems and solutions can be found on the Novatech web site at www.novatech.com.au when any are identified.

13.1 First Approach

The probe will not heat up.

Turn the power off, remove and check 2 x 20mm glass fuses. If either of them is blown, check the probe heater resistance between the two white wires that come from the probe. It should be 110 +/- 15 ohms, and both wires should be open circuit to earth. If not, replace the probe.

Is the 'B' shown on the bottom left hand corner of the display? If not, check that the burner is enabled with either a link between terminals 10&11, BURNER INPUT, or is enabled with a connection to a voltage-free contact from the main fuel valve to these terminals.

The display is blank and there is no backlight on.

Measure the power supply voltages at the test points labelled COMM and +5v at the right-hand side of the main PCB 1730-1. It should be 5 +/- 0.15v.

Turn off the power and remove the main shield. Check that the plug-in fuse FS1 has not blown. It should only be replaced with a 1A, 250v fuse if it has blown.

Is the mains power being supplied to terminals 36&37 and is it between 100 and 240VAC? If may be necessary to replace the switch mode power supply, PS5, APC-5S.

An 'ADC Calibration Fail' alarm has occurred.

Turn the transmitter off and remove the main shield. Turn the transmitter back on and measure the voltages on the 'Acom' test points. With the negative lead on the centre terminal the other 2 terminals should measure 12 +/-0.3v. If not, replace the small DC-DC converter PS4.

An 'Output 1 (2) Failure' alarm has occurred.

Turn the transmitter off and remove the main shield. Turn the transmitter back on and measure the voltages on the 'D1com' test points. With the negative lead on the centre terminal the other 2 terminals should measure 12 +/-0.3v. If not, replace the small DC-DC converter PS4.

A 'Heater 1 (2) Failure' alarm has occurred.

The software has found that the SSR4 has failed. If a single oxygen probe is being used and you need to get the transmitter back working quickly, use the CALIBRATION menu function 18, Heater SSR Select, to change the heater output terminals. See chapter 8.2.9, Heater SSR fault correction.

A 'BBRAM Fail' alarm has occurred

Replace the BBRAM, MEM1 on the 1730-1 main PCB.

13.2 Detailed Fault Analysis

The 1732 transmitter has a diagnostics mode built into the software. This mode allows detailed analysis of the hardware of the transmitter, but does require a level of competence in electronics.

The diagnostics mode is selectable by turning the 'Diagnostics' DIP switch to ON and then turn on the power.

There is a separate Diagnostics Mode Manual available that describes its use. Ask Novatech for more details.

This page has been intentionally left blank.

14.1 Transmitter Maintenance

The 1732 transmitter has several hardware checking systems that confirm the correct operation of the transmitter and raise an alarm if there is a fault detected. Because of this system, the transmitter only requires periodic maintenance. Novatech recommends an annual check of the transmitter.

The annual check should include the following items –

1. Measure and record the reference voltages, and check that the correct voltages are set in the calibration menu
2. Check that the reference air flow from the port on the bottom of the transmitter case is between 100 and 300cc/m
3. Check for contamination and potential blockage of the reference air filter that is mounted on the bottom of the transmitter case
4. If an external burner interlock has been connected (terminals 10 & 11), check that if one of the wires is disconnected the probe heater is disabled (1231 probes only)
5. Check the integrity of the cable. Particularly check the main power supply cable and the probe cable for any damage.
6. Check the integrity of the earth connections in the transmitter

14.2 Cleaning

The 1732 transmitter is made in an IP65 / IP54 rated diecast case. It is painted with a tough ripple finish power coating to maintain a clean look. However, if it is necessary to clean the case use either a warm soapy water solution or an isopropyl alcohol.

A build-up of dust on or around the transmitter should be removed before the cabinet door is opened. If there is a build-up of dust inside the cabinet check the door O-ring seal for damage and replace it if necessary.

Take care when wiping the display window to avoid scratching the surface.

If the filters of the probe (if fitted) become blocked, use an ultrasonic cleaner with a few drops of household detergent. If the filters cannot be cleaned this way replace the sintered filters.

The filter in the base of the analyser may become blocked if the analyser is operating in a dusty environment. It is available as a field replacement item.

14.3 Replacement parts

The following list identifies field replaceable parts –

Stock number	Description
18020	1730-1 Main PCB
18021	1730-2 Display PCB
15039	MP-24E Reference air pump
14105	Fuse - M205 3.15A 250V fuse (pack of 5)
14093	Instruction manual
18064	EEROM 173x firmware
11040	FIL-230 Titanium sintered filter, 30um
11041	FIL-215 Titanium sintered filter, 15um
14123	Filter – analyser bulkhead

15. INDEX

1230 Oxygen Probes	10
Alarms	51
Clearing the Alarm Log	45
Common	23, 53
Enabling Process Alarms	35
Process	55
Relay Options	56
Relay Wiring	23
Auxiliary Thermocouple	17, 23
Calibration	57
Calibration gas check	26
Calibration Menu	47
Calibration of the sensor	26
Cold start	58
Commissioning Menu	37
Communications port options	45
Connecting the power	25
Connections, electrical	19
Damping factor	35
Date / Time	39
Display units, oxygen	30
Dust in the flue gas	27
Filter purging	26
Fuel selection	44
Gas calibration check	24, 58, 59
Graphical display	29
Heater interlock relays	21
Installing a 1231 Oxygen Probe	15
Installing a 1234 Oxygen sensor	17
Keypad	30
Lower line	34
Mains voltage detection	49
MODBUS connection	25
Mounting the Transmitter	15
Number of Probes	39
Outputs, 4-20mA	37, 40
Pressure compensation	27, 40
Pressure Transducer	27
Probe Cable	22
Probe offset entry	34
Purge	59
Purge and calibration connections	24
Reference air connection	25
Reference air pump options	44
Reference Voltages	48
Run mode	26
Setup Menu	33
Functions	34
Software upgrades	61
Specifications	12
Specifications - Hardware	11
Specifications - Software	14
SSR Fault Correction	49
Stratification	27
Temperature units	41
Troubleshooting	63, 65
Voltage, mains supply	11
Warnings	7

APPENDIX 1, CONSTITUENT VALUES FOR VARIOUS FUELS

If the transmitter is set up to have readout or output of combustibles, oxygen deficiency, maximum carbon dioxide or combustion efficiency, then the fuel constituents must be entered. Any or all of the variables can be modified and entered in COMMISSIONING menu functions #50 to 56. (See chapter 7.2.25 Selecting the Correct Fuel). Your fuel supplier or chemist should be able to give you all these values.

A is the heat of combustion of the fuel per gram atom of contained carbon.

H is the H/C atom ratio in the fuel.

O is the O/C atom ratio in the fuel.

N is the N/C atom ratio in the fuel.

S is the S/C atom ratio in the fuel.

M is the ratio of H₂O molecules to C atoms in the fuel

FUEL	A	H	O	N	S	M
Blast Furnace Gas	50.55	0.08	1.3	3.08	b	a
Coke Oven Gas	256.88	5.6	0.25	0.23	b	a
Producer Gas	101.98	1.18	1.02	2.9	b	a
Natural Gas	209.9	3.86	0	0.1	0	0
Propane, Natural	176.4	2.69	0	0	0	0
Butane, Refinery	166.1	2.34	0	0	0	0
Methanol	172.59	3.97	1	-	-	-
Gasoline, Motor	157.58	2.01	0	0	0	0
No 1 Distillate Oil	149.65	1.83	0	-	0	-
No 2 Distillate Oil	145.18	1.71	-	-	0	-
No 4 Fuel Oil	145.54	1.6	-	-	0.01	0
No 5 Residual Oil	142.25	1.44	-	0	0	0
No 6 Residual Oil	136.52	1.25	0.01	0	0	0
Wood, Non-Resinous	110.91	2.26	1.07	0	0	c
Coal, Bituminous	116.88	0.74	0.05	0	0	0.03
Coal, Anthracite	104.98	0.35	0.05	0	0.01	0.04
Coke	99.63	0.11	0.01	0.01	0	0.01

- a. The moisture level varies depending on the process details. The calculated values assume M = O.
- b. The sulphur level varies depending on the process details. The calculated values assume S = O.
- c. Variable.

Values calculated from the North American Combustion Handbook Volume 1, Tables 2.1a and 2.1b.

APPENDIX 2, PROBE EMF TABLES

ZIRCONIA OXYGEN SENSOR OUTPUT (mV)
PROBE TYPE 1231, SENSOR TYPE 1234

OXYGEN %	Probe EMF @ 720°C (1320°F)	OXYGEN %	Probe EMF @ 720°C (1320°F)
20.95	0	10.0	15.930
20.5	0.517	9.5	17.033
20.0	1.046	9.0	18.196
19.5	1.589	8.5	19.426
19.0	2.147	8.0	20.730
18.5	2.719	7.5	22.120
18.0	3.306	7.0	23.607
17.5	3.911	6.5	25.204
17.0	4.533	6.0	26.930
16.5	5.173	5.5	28.808
16.0	5.834	5.0	30.867
15.5	6.515	4.5	33.145
15.0	7.219	4.0	35.695
14.5	7.947	3.5	38.590
14.0	8.700	3.0	41.940
13.5	9.481	2.5	45.913
13.0	10.292	2.0	50.797
12.5	11.134	1.5	57.135
12.0	12.011	0.9	66.182
11.5	12.925	0.4	82.168
11.0	13.881	0.2	99.518
10.5	14.881	0.1	114.347

'K' Type TC 29.965 mV @ 720°C (1320°F)

These tables are based on the Nernst equation:

$$EMF = \frac{T}{46.421} \times \log_e \left(\frac{20.95}{O_2} \right) \text{ Where } T \text{ is the probe temperature } ^\circ\text{K}$$

ZIRCONIA OXYGEN PROBE OUTPUT (mV)
PROBE TYPE 1232

OXYGEN %	TEMPERATURE °C (°F)								
	600 (1110)	700 (1290)	800 (1470)	900 (1650)	1000 (1830)	1100 (2010)	1200 (2190)	1300 (2370)	1400 (2550)
20	0.873	0.973	1.073	1.173	1.273	1.373	1.473	1.573	1.673
19.5	1.349	1.504	1.658	1.813	1.967	2.122	2.276	2.431	2.585
19	1.838	2.048	2.259	2.469	2.680	2.890	3.100	3.311	3.521
18.5	2.339	2.607	2.875	3.143	3.411	3.679	3.947	4.215	4.483
18	2.855	3.182	3.509	3.835	4.162	4.489	4.816	5.143	5.470
17.5	3.385	3.772	4.160	4.547	4.935	5.323	5.710	6.098	6.485
17	3.930	4.380	4.830	5.280	5.730	6.180	6.630	7.080	7.530
16.5	4.491	5.006	5.520	6.034	6.549	7.063	7.578	8.092	8.606
16	5.070	5.651	6.231	6.812	7.393	7.973	8.554	9.135	9.715
15.5	5.667	6.316	6.965	7.614	8.263	8.913	9.562	10.211	10.860
15	6.284	7.004	7.723	8.443	9.163	9.882	10.602	11.322	12.042
14.5	6.922	7.714	8.507	9.300	10.093	10.885	11.678	12.471	13.263
14	7.582	8.450	9.318	10.187	11.055	11.923	12.792	13.660	14.528
13.5	8.266	9.212	10.159	11.106	12.052	12.999	13.946	14.892	15.839
13	8.976	10.004	11.032	12.060	13.087	14.115	15.143	16.171	17.199
12.5	9.713	10.826	11.938	13.051	14.163	15.276	16.388	17.500	18.613
12	10.481	11.682	12.882	14.082	15.283	16.483	17.684	18.884	20.084
11.5	11.282	12.574	13.866	15.158	16.450	17.742	19.034	20.326	21.618
11	12.118	13.506	14.893	16.281	17.669	19.057	20.445	21.833	23.220
10.5	12.993	14.481	15.969	17.457	18.945	20.433	21.921	23.409	24.897
10	13.911	15.504	17.097	18.690	20.283	21.876	23.469	25.063	26.656
9.5	14.875	16.579	18.283	19.986	21.690	23.394	25.097	26.801	28.504
9	15.892	17.712	19.533	21.353	23.173	24.993	26.813	28.633	30.453
8.5	16.967	18.911	20.854	22.797	24.740	26.684	28.627	30.570	32.513
8	18.108	20.182	22.255	24.329	26.403	28.477	30.551	32.625	34.698
7.5	19.322	21.535	23.747	25.960	28.173	30.386	32.599	34.812	37.025
7	20.619	22.981	25.342	27.704	30.065	32.427	34.788	37.150	39.511
6.5	22.013	24.534	27.056	29.577	32.098	34.619	37.140	39.661	42.182
6	23.519	26.212	28.906	31.600	34.293	36.987	39.680	42.374	45.067
5.5	25.155	28.036	30.917	33.798	36.679	39.560	42.442	45.323	48.204
5	26.948	30.035	33.121	36.207	39.293	42.380	45.466	48.552	51.639
4.5	28.930	32.243	35.557	38.870	42.183	45.496	48.810	52.123	55.436
4	31.145	34.712	38.279	41.846	45.413	48.980	52.547	56.115	59.682
3.5	33.657	37.512	41.366	45.221	49.076	52.930	56.785	60.640	64.494
3	36.557	40.743	44.930	49.117	53.303	57.490	61.677	65.864	70.050
2.5	39.986	44.565	49.145	53.724	58.304	62.883	67.463	72.042	76.622
2	44.183	49.243	54.303	59.364	64.424	69.484	74.544	79.604	84.665
1.5	49.594	55.274	60.954	66.634	72.314	77.994	83.674	89.354	95.034
1	57.221	63.774	70.327	76.881	83.434	89.988	96.541	103.094	109.648
0.5	70.258	78.305	86.351	94.398	102.445	110.491	118.538	126.584	134.631
0.2	87.493	97.514	107.534	117.554	127.575	137.595	147.616	157.636	167.657
Thermocouple mV									
'K' Type	24.905	29.129	33.275	37.326	41.276	45.119	48.838	52.410	-
'J' Type	33.102	39.132	45.494	51.877	57.953	63.792	69.553	-	-
'R' Type	5.583	6.743	7.950	9.205	10.506	11.850	13.228	14.629	16.040
'S' Type	5.239	6.275	7.345	8.449	9.587	10.757	11.951	13.159	14.373
'N' Type	20.613	24.527	28.455	32.371	36.256	40.087	43.846	47.513	-

These tables are based on the Nernst equation:

$$EMF = \frac{T}{46.421} \times \log_e \left(\frac{20.95}{O_2} \right) \text{ Where } T \text{ is the probe temperature } ^\circ\text{K}$$

Thermocouple information from NIST ITS-90 data tables

APPENDIX 3, % OXYGEN SCALE TO LOGARITHMIC

OXYGEN %	FULL SCALE %
0.1	0
0.15	7.65
0.2	13.1
0.3	20.7
0.4	26.2
0.6	33.8
0.8	39.2
1	43.5
1.5	51.1
2	56.5
3	64.2
4	69.6
6	77.3
8	82.7
10	86.9
12	90.4
14	93.3
16	95.8
18	98
20	100

APPENDIX 4, MODBUS™

The Novatech 1732 transmitter has the ability to work as a Modbus slave node on serial RS-232 or 3-wire RS-485 via RTU mode transmissions. By accessing information stored in the input and holding registers it is possible to access runtime variables, alarm conditions and modify the device configuration.

The implementation of the Modbus protocol is limited to the specific command set relevant to reading and writing register variables. Attempting to send unrecognised commands will result in appropriate error responses

MODBUS™ Functions Supported:-

- 0x03: Read Holding Registers
- 0x04: Read Input Registers
- 0x06: Write Single Holding Register
- 0x08: (return query data – for loopback testing)
- 0x10: Write Multiple Holding Registers
- 0x16: Mask Write Holding Register
- 0x17: Read/Write Multiple Holding Registers
- 0x2B: Encapsulated Interface (read device information)
- 0x41: Special Instruction Function

Serial Configuration

The serial configuration for the slave device is accessed in the Commissioning menu of the transmitter. Default settings are highlighted in bold.

Baud Rate	2400, 4800, 9600, 19200 , 38400, 57600, 115200
Parity	Even , Odd, None
Stop Bits	1
Interface	RS-485, RS-232

All holding register addresses contain a single 16 bit value, however some variables span multiple holding registers to yield a single 32 bit variable.

When reading register values be aware that the byte order of data within registers may differ from that of the target system.

Modbus Protocol

The Modbus over serial line protocol defines a messaging system for master/slave communications. Only one master device may be connected to any network with one or several slave nodes.

In unicast mode, the master initiates communication with a specific slave node by sending a request message. The slave processes the request and returns a reply message containing the requested information or a confirmation that the request was fulfilled.

Modbus requests are transmitted as a formed request frame with a CRC for data integrity checking. The frame for each request and reply type will vary somewhat, but will always have the basic structure described below:

1 byte	1 byte	up to 255 bytes	2 bytes
slave address	function code	data	checksum

Detailed information regarding the implementation of the Modbus protocol can be obtained from the website of the Modbus Organisation.

<http://www.modbus-ida.org>

Internal Representation of Dates & Alarm Status

The transmitter stores all dates as an unsigned 32bit count of seconds elapsed since 1-Jan 2004.

Alarm status is stored as an integer value:

0	clear	2	active
1	self cleared	3	acknowledged

1732 Transmitter Modbus Input Register Table for firmware v1.16 and newer

Reg	Description	Bits	Type	Reg	Description	Bits	Type		
Probe 1 Runtime Data	0	Oxygen %	32	floating point	Analyser Runtime Data	34	Auxilliary TC Temperature degC	32	floating point
	2	EMF mV	32	floating point		36	Auxilliary TC Open Ct Flag	16	boolean
	4	Temperature degC	32	floating point		37	4-20mA Outputs Frozen	16	boolean
	6	Thermocouple Open Ct Flag	16	boolean		38	Ambient Temperature	16	signed integer
	7	Temperature Low Flag	16	boolean		39	Maximum Ambient Temperature	16	signed integer
	8	Impedance kOhms	32	floating point		40	Average Oxygen	32	floating point
	10	Oxygen Deficiency	32	floating point		42	Reference Air Oxygen	32	floating point
	12	% Combustibles	32	floating point		44	Boiler Efficiency %	32	floating point
	14	Maximum Theoretical CO	32	floating point		46	Burner Runtime Minutes	32	unsigned integer
	16	Heater 1 Output	16	unsigned integer		48	Burner On Time Minutes	32	unsigned integer
Probe 2 Runtime Data	17	Oxygen %	32	floating point	Event Times	50	Current Date & Time	32	unsigned integer
	19	EMF mV	32	floating point		52	Next Purge/Cal 1 Time	32	unsigned integer
	21	Temperature degC	32	floating point		54	Next Purge/Cal 2 Time	32	unsigned integer
	23	Thermocouple Open Ct Flag	16	boolean		56	Next Probe Impedance Check	32	unsigned integer
	24	Temperature Low Flag	16	boolean	Relay Status	58	Relay 1 Status	16	unsigned integer
	25	Impedance kOhms	32	floating point		59	Relay 2 Status	16	unsigned integer
	27	Oxygen Deficiency	32	floating point		60	Relay 3 Status	16	unsigned integer
	29	% Combustibles	32	floating point		61	Common Relay Status	16	unsigned integer
	31	Maximum Theoretical CO	32	floating point		Last Alarm Active Time	62	Mains Power	16
	33	Heater 2 Output	16	unsigned integer	63		Mains Frequency	16	unsigned integer
Current Alarm Status	64	Heater 1 Fail Alarm	16	unsigned integer	92		DAC Output 1 mA	16	unsigned integer
	65	Heater 2 Fail Alarm	16	unsigned integer	93		DAC Output 2 mA	16	unsigned integer
	66	Probe 1 Hi Impedance	16	unsigned integer	Last Alarm State Cleared Time		94	Heater 1 Fail Alarm	32
	67	Probe 2 Hi Impedance	16	unsigned integer		96	Heater 2 Fail Alarm	32	unsigned integer
	68	Probe 1 Thermocouple Open Ct	16	unsigned integer		98	Probe 1 Hi Impedance	32	unsigned integer
	69	Probe 2 Thermocouple Open Ct	16	unsigned integer		100	Probe 2 Hi Impedance	32	unsigned integer
	70	Auxilliary Thermocouple Open Ct	16	unsigned integer		102	Probe 1 Thermocouple Open Ct	32	unsigned integer
	71	Reference Air Pump Fail	16	unsigned integer		104	Probe 2 Thermocouple Open Ct	32	unsigned integer
	72	Reference Air Pump Overload	16	unsigned integer		106	Auxilliary Thermocouple Open Ct	32	unsigned integer
	73	Battery Backup RAM Failure	16	unsigned integer		108	Reference Air Pump Fail	32	unsigned integer
	74	Internal Alarm Log Memory Failure	16	unsigned integer		110	Reference Air Pump Overload	32	unsigned integer
	75	Internal ADC Fail	16	unsigned integer		112	Battery Backup RAM Failure	32	unsigned integer
	76	Internal DAC Output 1 Fail	16	unsigned integer		114	Internal Alarm Log Memory Failure	32	unsigned integer
	77	Internal DAC Output 2 Fail	16	unsigned integer		116	Internal ADC Fail	32	unsigned integer
	78	Heater 1 SSR Relay Fail	16	unsigned integer		118	Internal DAC Output 1 Fail	32	unsigned integer
	79	Heater 2 SSR Relay Fail	16	unsigned integer		120	Internal DAC Output 2 Fail	32	unsigned integer
	80	Heater SSR Leaking	16	unsigned integer		122	Heater 1 SSR Relay Fail	32	unsigned integer
81	Probe 1 Blocked	16	unsigned integer	124		Heater 2 SSR Relay Fail	32	unsigned integer	
82	Probe 2 Blocked	16	unsigned integer	126		Heater SSR Leaking	32	unsigned integer	
83	Gas 1 Calibration Error	16	unsigned integer	128	Probe 1 Blocked	32	unsigned integer		
84	Gas 2 Calibration Error	16	unsigned integer	130	Probe 2 Blocked	32	unsigned integer		
85	Oxygen 1 Low	16	unsigned integer	132	Gas 1 Calibration Error	32	unsigned integer		
86	Oxygen 2 Low	16	unsigned integer	134	Gas 2 Calibration Error	32	unsigned integer		
87	Oxygen 1 Very Low	16	unsigned integer	136	Oxygen 1 Low	32	unsigned integer		
88	Oxygen 2 Very Low	16	unsigned integer	138	Oxygen 2 Low	32	unsigned integer		
89	Oxygen 1 High	16	unsigned integer	140	Oxygen 1 Very Low	32	unsigned integer		
90	Oxygen 2 High	16	unsigned integer	142	Oxygen 2 Very Low	32	unsigned integer		
91	Oxygen Deviation	16	unsigned integer	144	Oxygen 1 High	32	unsigned integer		
Last Alarm User Acknowledged Time	150	Heater 1 Fail Alarm	32	unsigned integer	146	Oxygen 2 High	32	unsigned integer	
	152	Heater 2 Fail Alarm	32	unsigned integer	148	Oxygen Deviation	32	unsigned integer	
	154	Probe 1 Hi Impedance	32	unsigned integer	Last Alarm State Cleared Time	206	Heater 1 Fail Alarm	32	unsigned integer
	156	Probe 2 Hi Impedance	32	unsigned integer		208	Heater 2 Fail Alarm	32	unsigned integer
	158	Probe 1 Thermocouple Open Ct	32	unsigned integer		210	Probe 1 Hi Impedance	32	unsigned integer
	160	Probe 2 Thermocouple Open Ct	32	unsigned integer		212	Probe 2 Hi Impedance	32	unsigned integer
	162	Auxilliary Thermocouple Open Ct	32	unsigned integer		214	Probe 1 Thermocouple Open Ct	32	unsigned integer
	164	Reference Air Pump Fail	32	unsigned integer		216	Probe 2 Thermocouple Open Ct	32	unsigned integer
	166	Reference Air Pump Overload	32	unsigned integer		218	Auxilliary Thermocouple Open Ct	32	unsigned integer
	168	Battery Backup RAM Failure	32	unsigned integer		220	Reference Air Pump Fail	32	unsigned integer
	170	Internal Alarm Log Memory Failure	32	unsigned integer		222	Reference Air Pump Overload	32	unsigned integer
	172	Internal ADC Fail	32	unsigned integer		224	Battery Backup RAM Failure	32	unsigned integer
	174	Internal DAC Output 1 Fail	32	unsigned integer		226	Internal Alarm Log Memory Failure	32	unsigned integer
	176	Internal DAC Output 2 Fail	32	unsigned integer		228	Internal ADC Fail	32	unsigned integer
178	Heater 1 SSR Relay Fail	32	unsigned integer	230		Internal DAC Output 1 Fail	32	unsigned integer	
180	Heater 2 SSR Relay Fail	32	unsigned integer	232		Internal DAC Output 2 Fail	32	unsigned integer	
182	Heater SSR Leaking	32	unsigned integer	234	Heater 1 SSR Relay Fail	32	unsigned integer		
184	Probe 1 Blocked	32	unsigned integer	236	Heater 2 SSR Relay Fail	32	unsigned integer		
186	Probe 2 Blockd	32	unsigned integer	238	Heater SSR Leaking	32	unsigned integer		
188	Gas 1 Calibration Error	32	unsigned integer	240	Probe 1 Blocked	32	unsigned integer		
190	Gas 2 Calibration Error	32	unsigned integer	242	Probe 2 Blockd	32	unsigned integer		
192	Oxygen 1 Low	32	unsigned integer	244	Gas 1 Calibration Error	32	unsigned integer		
194	Oxygen 2 Low	32	unsigned integer	246	Gas 2 Calibration Error	32	unsigned integer		
196	Oxygen 1 Very Low	32	unsigned integer	248	Oxygen 1 Low	32	unsigned integer		
198	Oxygen 2 Very Low	32	unsigned integer	250	Oxygen 2 Low	32	unsigned integer		
200	Oxygen 1 High	32	unsigned integer	252	Oxygen 1 Very Low	32	unsigned integer		
202	Oxygen 2 High	32	unsigned integer	254	Oxygen 2 Very Low	32	unsigned integer		
204	Oxygen Deviation	32	unsigned integer	256	Oxygen 1 High	32	unsigned integer		
				258	Oxygen 2 High	32	unsigned integer		
				260	Oxygen Deviation	32	unsigned integer		

1732 Transmitter Modbus Holding Register Table for firmware v1.16 and newer

Reg	Description	Bits	Type	Reg	Description	Bits	Type		
0	00	50mV Reference Voltage	32	unsigned integer	57	39	Transmitter 2 Output	16	unsigned integer
2	02	200mV Reference Voltage	32	unsigned integer	58	3A	Transmitter 2 Zero (Linear Oxygen 1)	16	unsigned integer
4	04	1200mV Reference Voltage	32	unsigned integer	59	3B	Transmitter 2 Zero (Linear Oxygen Avg)	16	unsigned integer
6	06	2500mV Reference Voltage	32	unsigned integer	60	3C	Transmitter 2 Zero (Very Low O2 1)	16	unsigned integer
8	08	Single/Dual Probe	16	boolean	61	3D	Transmitter 2 Zero (Reducing O2 1)	16	unsigned integer
9	09	Service Date	16	unsigned integer	62	3E	Transmitter 2 Zero (Oxygen Deficiency 1)	16	unsigned integer
10	0A	Probe 1 Type	16	unsigned integer	63	3F	Transmitter 2 Zero (Boiler Efficiency)	16	unsigned integer
11	0B	Probe 1 TC Type	16	unsigned integer	64	40	Transmitter 2 Zero (Combustibles % 1)	16	unsigned integer
12	0C	Probe 1 Offset	16	signed integer	65	41	Transmitter 2 Zero (Probe 1 EMF)	16	unsigned integer
13	0D	Probe 2 Type	16	unsigned integer	66	42	Transmitter 2 Zero (Aux TC Temp)	16	unsigned integer
14	0E	Probe 2 TC Type	16	unsigned integer	67	43	Transmitter 2 Span (Linear Oxygen 1)	16	unsigned integer
15	0F	Probe 2 Offset	16	signed integer	68	44	Transmitter 2 Span (Linear Oxygen Avg)	16	unsigned integer
16	10	Aux TC Type	16	unsigned integer	69	45	Transmitter 2 Span (Very Low O2 1)	16	unsigned integer
17	11	Flue Pressure Units	16	unsigned integer	70	46	Transmitter 2 Span (Reducing O2 1)	16	unsigned integer
18	12	Flue Pressure Value	16	signed integer	71	47	Transmitter 2 Span (Oxygen Deficiency 1)	16	unsigned integer
19	13	Temperature Units	16	unsigned integer	72	48	Transmitter 2 Span (Boiler Efficiency)	16	unsigned integer
20	14	Oxygen Display Units	16	unsigned integer	73	49	Transmitter 2 Span (Combustibles % 1)	16	unsigned integer
21	15	Lower Line Items	64	bitmask	74	4A	Transmitter 2 Span (Dry CO2 % 1)	16	unsigned integer
25	19	Reference Air Pump	16	unsigned integer	75	4B	Transmitter 2 Span (Probe 1 EMF)	16	unsigned integer
26	1A	Reference Air Pump Voltage	16	unsigned integer	76	4C	Transmitter 2 Span (Aux TC Temp)	16	unsigned integer
27	1B	Reference Air RH%	16	unsigned integer	77	4D	Transmitter 2 4-20mA Cal Mode	16	unsigned integer
28	1C	Oxygen Damping Factor	16	unsigned integer	78	4E	Transmitter 2 4mA Trim	16	unsigned integer
29	1D	Ambient Temperature Offset	16	signed integer	79	4F	Transmitter 2 20mA Trim	16	unsigned integer
30	1E	Transmitter 4-20mA / 0-20mA Select	16	unsigned integer	80	50	Enable Process Alarms	16	boolean
31	1F	Transmitter Output Limiting for Low Ten	16	unsigned integer	81	51	High Oxygen Alarm	32	unsigned integer
32	20	Manual Mains Voltage Select	16	unsigned integer	83	53	High Oxygen Alarm Delay	16	unsigned integer
33	21	Manual Mains Frequency Select	16	unsigned integer	84	54	Low Oxygen Alarm	32	unsigned integer
34	22	Transmitter 1 Output	16	unsigned integer	86	56	Low Oxygen Alarm Delay	16	unsigned integer
35	23	Transmitter 1 Zero (Linear Oxygen 1)	16	unsigned integer	87	57	Very Low Oxygen Alarm	32	unsigned integer
36	24	Transmitter 1 Zero (Linear Oxygen Avg)	16	unsigned integer	89	59	Very Low Oxygen Alarm Delay	16	unsigned integer
37	25	Transmitter 1 Zero (Very Low O2 1)	16	unsigned integer	90	5A	Oxygen Deviation Alarm	32	unsigned integer
38	26	Transmitter 1 Zero (Reducing O2)	16	unsigned integer	92	5C	Oxygen Deviation Alarm Delay	16	unsigned integer
39	27	Transmitter 1 Zero (Oxygen Deficiency 1)	16	unsigned integer	93	5D	Alarm Relay 1 Options	64	bitmask
40	28	Transmitter 1 Zero (Boiler Efficiency)	16	unsigned integer	97	61	Alarm Relay 2 Options	64	bitmask
41	29	Transmitter 1 Zero (Dry CO2)	16	unsigned integer	101	65	Alarm Relay 3 Options	64	bitmask
42	2A	Transmitter 1 Zero (Probe 1 EMF)	16	unsigned integer	105	69	Common Relay Options	64	bitmask
43	2B	Transmitter 1 Zero (Aux TC Temp)	16	unsigned integer	109	6D	Fuel Heat of combustion per gram atom C	16	unsigned integer
44	2C	Transmitter 1 Span (Linear Oxygen 1)	16	unsigned integer	110	6E	Fuel Hydrogen/Carbon atom ratio	16	unsigned integer
45	2D	Transmitter 1 Span (Linear Oxygen Avg)	16	unsigned integer	111	6F	Fuel Oxygen/Carbon atom ratio	16	unsigned integer
46	2E	Transmitter 1 Span (Very Low O2 1)	16	unsigned integer	112	70	Fuel Nitrogen/Carbon atom ratio	16	unsigned integer
47	2F	Transmitter 1 Span (Reducing O2 1)	16	unsigned integer	113	71	Fuel Sulphur/Carbon atom ratio	16	unsigned integer
48	30	Transmitter 1 Span (Oxygen Deficiency 1)	16	unsigned integer	114	72	Fuel H2O molecules/Carbon atom ratio	16	unsigned integer
49	31	Transmitter 1 Span (Boiler Efficiency)	16	unsigned integer	115	73	Solenoid 1 Operation (Cal/Purge)	16	unsigned integer
50	32	Transmitter 1 Span (Combustibles % 1)	16	unsigned integer	116	74	Solenoid 1 Auto/Man	16	unsigned integer
51	33	Transmitter 1 Span (Dry CO2 % 1)	16	unsigned integer	117	75	Solenoid 1 Start Time	16	unsigned integer
52	34	Transmitter 1 Span (Probe 1 EMF)	16	unsigned integer	118	76	Solenoid 1 Period	16	unsigned integer
53	35	Transmitter 1 Span (Aux TC Temp)	16	unsigned integer	119	77	Solenoid 1 Purge/Cal Duration	16	unsigned integer
54	36	Transmitter 1 4-20mA Cal Mode	16	unsigned integer	120	78	Solenoid 1 Post P/C Freeze	16	unsigned integer
55	37	Transmitter 1 4mA Trim	16	unsigned integer	121	79	Solenoid 1 Calibration Gas Content	16	unsigned integer
56	38	Transmitter 1 20mA Trim	16	unsigned integer	122	7A	Solenoid 1 Calibration Gas Positive Error	16	unsigned integer
					123	7B	Solenoid 1 Calibration Gas Negative Error	16	unsigned integer
					124	7C	Solenoid 2 Operation (Cal/Purge)	16	unsigned integer
					125	7D	Solenoid 2 Auto/Man	16	unsigned integer
					126	7E	Solenoid 2 Start Time	16	unsigned integer
					127	7F	Solenoid 2 Period	16	unsigned integer
					128	80	Solenoid 2 Purge/Cal Duration	16	unsigned integer
					129	81	Solenoid 2 Post P/C Freeze	16	unsigned integer
					130	82	Solenoid 2 Calibration Gas Content	16	unsigned integer
					131	83	Solenoid 2 Calibration Gas Positive Error	16	unsigned integer
					132	84	Solenoid 2 Calibration Gas Negative Error	16	unsigned integer

0x41 Special Instruction Function

This command allows you to interact with the transmitter allowing access to functionality that would otherwise only be accessible via the keypad. The request length will vary from one command to the next depending on what arguments are required. Requests are formed the same as other Modbus requests:

1 byte	1 byte	1 byte	0 - 4 bytes	2 bytes
slave address	command code	function code	arguments	checksum

Function Code	Command	Arguments
0x01	Accept All Active Alarms	none
0x02	remote set key down	1 byte keymask
0x03	remote reset key down	1 byte keymask
0x04	Initiate Probe Impedance Check	none
0x05	Set Internal Clock	4 byte rtc*

* date expressed as seconds since 1-Jan 2004

END OF LIFE TREATMENT AND FINAL DISPOSAL

Instructions for Disposal by Users

The Waste from Electrical and Electronic Equipment (WEEE) EU Directive aims to reduce the amount of WEEE going to landfill.

The symbol shown below is on the product or on its packaging, which indicates that this product must not be disposed of with other waste. Instead, it is the user's responsibility to separate their waste electrical and electronic equipment and hand it over to a designated collection point for the disposal of.



To further reduce waste to landfill, the steel and aluminium parts of probes/sensors may be separated and handed to a metals recycler.

The separate collection and recycling of your waste equipment at the time of disposal will help to conserve natural resources and ensure that it is recycled in a manner that protects human health and the environment. For more information about where you can drop off your waste equipment for recycling, please contact your local city office or your general waste disposal service.

DECLARATION OF CONFORMITY

Application of Council Directives: 2004/108/EC
2006/95/EC
2011/65/EU with 2015/863 amendment

Standards to which conformity is declared:

EN61010-1:2010	Safety Requirements for Electrical Equipment for Measurement, Control and Laboratory Use.
EN50270:1999	Electromagnetic Compatibility – Electrical Apparatus for the Detection and Measurement of Combustible Gases, Toxic Gases or Oxygen
CFR47 FCC Part 15, Subpart B (Class A)	Electromagnetic Compatibility - Radiated and Conducted Emissions
AS60529:2004	Degree of Protection Provided By Enclosures (IP Code)

This product is manufactured in Australia under ISO9001:2015 quality systems and ISO14001:2015 environmental certification.

Manufacturer's name: *Novatech Controls Pty Ltd*

Manufacturer's address: *309 Reserve Road
Cheltenham VIC 3192
AUSTRALIA*

Type of equipment: *Oxygen Transmitter*

Model Number: *1730 Series Transmitter
1231 Oxygen Probe
1232 Oxygen Probe
1234 Oxygen Sensor*

I hereby declare that the equipment specified herein conforms to the above directive(s) and standards(s) in 2021.



Full Name: **Douglas Rice**
Position: **R & D Manager**