

Manual

ammo::lyser V2.1

fluor::lyser V2.1

August 2019 Release



Table of Contents

1	General	5
2	Safety Guidelines	6
2.1	Declaration of Conformity	6
2.2	Special Hazard Warning	6
3	Technical Description	7
3.1	Intended Use	7
3.2	Functional Principle	7
3.3	Product	8
3.4	Storage and Transport	11
3.5	Scope of Delivery	11
3.6	Product Updates and Other	11
4	Installation	12
4.1	Environment	12
4.2	Installation Notes for ammo::lyser / fluor::lyser	12
4.3	Mounting with Sensor Carrier	13
4.4	Mounting in Flow Cell	13
4.4.1	Mounting Adapter of Flow Cell	13
4.4.2	Mounting in Flow Cell for Tap Water	14
4.4.3	Mounting in Flow Cell for Waste Water	14
4.5	Connection of automatic Cleaning	15
5	Initial Startup	17
5.1	Controller for Operation	17
5.2	Connection to the Controller for Operation	17
5.3	Probe Initialisation	17
5.3.1	Probe Initialisation using con::lyte D-31x	17
5.3.2	Probe Initialisation using con::lyte D-320	18
5.3.3	Probe Initialisation using moni::tool	19
5.4	Probe Parameterisation	20
5.4.1	Probe Parameterisation using con::lyte D-31x	20
5.4.2	Probe Parameterisation using con::lyte D-320	20
5.4.3	Probe Parameterisation using moni::tool	21
6	Calibration	22
6.1	Types of Calibration	22
6.2	Notes for Calibration Procedure	22
6.3	Special Notes for Calibration of ISE Electrodes	23
6.4	Performing a Calibration	25
6.4.1	Calibration using con::lyte D-31x	25
6.4.2	Calibration using con::lyte D-320	26
6.4.3	Calibration using moni::tool	27
7	Data Management	29
7.1	Data Storage	29
7.2	Data Transfer	29
7.3	Data Visualisation	29

8	Functional Check	30
8.1	Check of Monitoring Station	30
8.2	Check of Readings	31
8.3	Check of Sensor Integrity	32
8.4	Check of Reading Accuracy	33
8.5	Check of Electrode Aging	33
9	Maintenance	34
9.1	Cleaning	34
9.2	Refurbishment of Electrodes	34
9.3	Replacement of Electrodes	35
10	Troubleshooting	36
10.1	Typical Error Pattern	36
10.2	Error Messages and Status Messages	38
10.3	Check of Device Settings	42
10.3.1	Check of Device Settings using con::lyte D-31x	42
10.3.2	Check of Device Settings using con::lyte D-320	42
10.3.3	Check of Device Settings using moni::tool	43
10.4	Modification of Device Settings	43
10.4.1	Modification of Device Settings using moni::tool	43
10.4.2	Modification of Device Settings using ana::pro	44
10.5	Return Consignment (RMA - Return Material Authorization)	45
11	Accessories	46
11.1	Installation	46
11.1.1	Connection Cable	46
11.1.2	Extension Cable	46
11.1.3	Sensor Mounting	46
11.1.4	Flow Cell Setup Tap Water	47
11.1.5	Flow Cell Setup Waste Water	47
11.1.6	System Panel micro::station / nano::station	48
11.1.7	Pressure Connection Set	48
11.2	Spare Parts	49
11.2.1	Reference Electrode	49
11.2.2	pH Electrode	49
11.2.3	Ammonium Electrode (NH ₄ -N)	49
11.2.4	Potassium Electrode (K)	50
11.2.5	Nitrate Electrode (NO ₃ -N)	50
11.2.6	Chloride Electrode (Cl)	50
11.2.7	Fluoride Electrode (F)	50
12	Technical Specifications	51

1 General

This manual contains, firstly, general information (chapter 1) and safety guidelines (chapter 2). The next chapter (chapter 3) provides a technical description of the s::can product itself as well as information regarding transport and storage of the product. In further chapters the installation (chapter 4) and the initial startup (chapter 5) are explained. Furthermore information regarding calibration of the device (chapter 6), data management (chapter 7), how to perform a functional check (chapter 8) and maintenance (chapter 9) can be found in this manual. Information regarding troubleshooting (chapter 10), the available accessories (chapter 11) and the technical specifications (chapter 12) complete the document.

Each term in this document that is marked *italic and underlined*, can be found on the display of your controller for operation or as lettering on your s::can product.

In spite of careful elaboration this manual may contain errors or incompleteness. s::can does not assume liability for errors or loss of data due to such faults in the manual. The original manual is published in English and German by s::can. This original manual serves as the reference in case discrepancies occur in versions of the manual after translation into third languages.

This manual and all information and figures contained therein are copyrighted. All rights (publishing, reproduction, printing, translation, storage) are reserved by s::can Messtechnik GmbH. Each reproduction or utilisation outside the permitted limits of the copyright law is not allowed without previous written consent from s::can Messtechnik GmbH. The reproduction of product names, registered trade names, designation of goods etc. in this manual does not imply that these names can be used freely by everyone; often these are registered trade marks, even if they are not marked as such.

This manual, at the time of its publication (see release date printed on the top of this document), concerns the s::can products listed in chapter 3. Information and technical specifications regarding these items in s::can manuals from earlier release dates are herewith replaced by this manual.

The electronic version (pdf-document) of this manual is available on the Customer Portal (Services for Customers) of the s::can website (www.s-can.at).

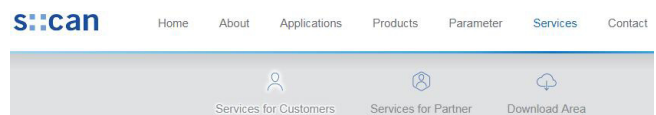

2 Safety Guidelines

Installation, electrical connection, initial startup, operation and maintenance of any s::can product as well as complete s::can measuring systems must only be performed by qualified personnel. This qualified personnel has to be trained and authorised by the plant operator or by s::can for these activities. The qualified personnel must have read and understood this manual and have to follow the instructions contained in this manual.



For proper initial startup of complete s::can measuring systems, the manuals for the controller and software used for operation (e.g. con::lyte, con::cube, con::nect, moni::tool), the connected probes and sensors as well as the used additional devices (e.g. compressor) have to be consulted.

The operator has to obtain the local operating permits and has to comply with the joint constraints associated with these. Additionally, the local legal requirements have to be observed (e.g. regarding safety of personnel and means of labour, disposal of products and materials, cleaning, environmental constraints). Before putting the measuring device into operation, the operator has to ensure that during mounting and initial startup – in case they are executed by the operator himself – the local legislation and requirements (e.g. regarding electrical connection) are observed.

All s::can products are leaving our factory in immaculate technical and safety conditions. Inappropriate or not intended use of the product, however, can cause danger! The manufacturer is not responsible for damage caused by incorrect or unauthorised use. Any kind of manipulation of the instrument is strictly prohibited - except for the activities described in this document. Conversions and changes to the device must not be made, otherwise all certifications and guarantee / warranty become invalid. For details regarding guarantee and warranty please refer to our general conditions of business.

2.1 Declaration of Conformity

This s::can product has been developed, tested and manufactured for electromagnetic compatibility (EMC) and according to applicable European standards, as defined in the declaration of conformity.

CE-marks are applied on the device. The declaration of conformity related to this marking can be requested from s::can or your local s::can sales partner or can be downloaded from the s::can Customer Portal.

2.2 Special Hazard Warning



Because the s::can measuring systems are frequently installed in industrial and communal waste water applications, one has to take care during mounting and demounting of the system, as parts of the device can be contaminated with dangerous chemicals or pathogenic germs. All necessary precautions should be taken to prevent endangering of one's health during work with the measuring device.

3 Technical Description

3.1 Intended Use

The ammo::lyser / fluor::lyser is an ion selective sensor designed for the continuous monitoring of dissolved Ammonium Nitrogen (NH₄-N) or Fluoride (F) respectively in waste water, surface water or drinking water. Depending on the sensor type different electrodes will be used. The measured value is displayed in mg/l.

Optional the sensor can be equipped with additional ion selective electrodes that measure the concentration of Nitrate Nitrogen (NO₃-N), Chloride (Cl), Potassium (K) or the pH-value. The last two parameters (K, pH) can be used to compensate cross sensitivities of the ammonium measurement. In that way a higher measuring accuracy can be reached compared to traditional ion selective sensors without such compensations for cross sensitivities.

The temperature of the medium will be measured continuously and is available as an additional parameter. Temperature will be used for correction of measured readings during the local calibration process.

In all types of applications, the respective acceptable limits, which are provided in the technical specifications in the respective s::can manuals, have to be observed. All applications falling outside of these limits, and which are not authorised by s::can Messtechnik GmbH in written form, do not fall under the manufacturer's liability.

The device must only be used for the purpose described in this manual. Use in applications not described in this manual, or modification of the device without written agreement from s::can, is not allowed. s::can is not liable for claims following from such unauthorised use. In such a case, the risks are the sole responsibility of the operator.

3.2 Functional Principle

The ammo::lyser / fluor::lyser measures the potential difference between the ion selective measuring electrode (ISE) and the reference electrode (see figure on the right). The voltage circuit is closed via the measuring medium.

The measuring electrode is equipped with a selective membrane (polymer, single crystal or glass) which measures changes of specific ion activity. The difference in specific ion activities generates a potential at the membrane interface. This potential is then measured against the stable potential of the reference electrode.

According to the Nernst equation the measured potential [mV] is proportional to the concentration of the specific ion.

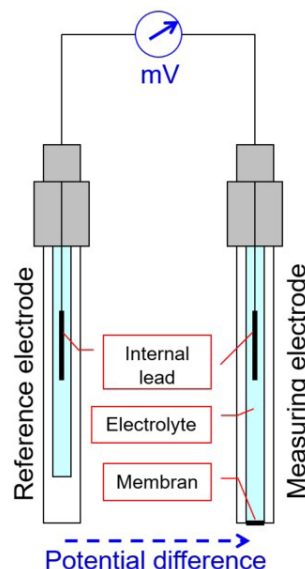

In addition, the ammo::lyser can be equipped with functionalities to compensate the Ammonium measurement for pH and Potassium.

■ pH compensation:

Increasing concentrations of NH₃-N (Ammonia) at pH > 7.5 (see figure on the right) cannot be detected by the ion selective electrode. Therefore the NH₄-N reading is below the real concentration. In order to eliminate this effect, the ammo::lyser can be equipped with a pH electrode.

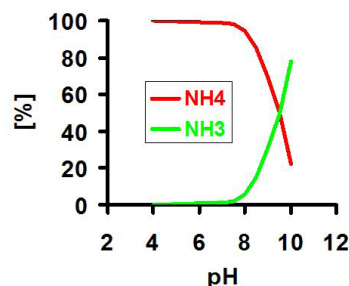
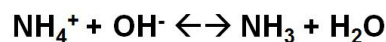

■ Potassium compensation:

The ion selective electrodes are specific for only one type of ion. Potassium ion has the same charge and similar size as Ammonium, therefore it will be detected by the measuring electrode and give less accurate, increased readings (see figure on the right).

In case of high and / or fluctuating Potassium concentration, the usage of a separate Potassium electrode for compensation of Ammonium reading can be used.

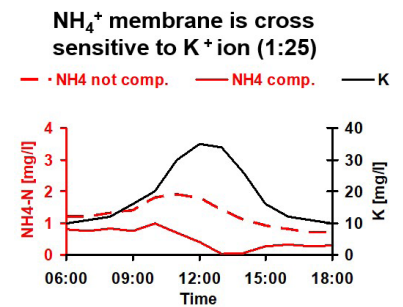

3.3 Product

The following device variants of the ammo::lyser / fluor::lyser are available. Regarding detailed information of the device variants please refer to the technical specifications located at the end of this manual.

Type	Specification	NH4-N	NO3-N	K	Cl	F	pH	Temp.
E-532-PRO-075	ammo::lyser with 7.5m fixed cable and Potassium compensation	X		X				X
E-532-PRO-000	ammo::lyser with plug connection and Potassium compensation	X		X				X
E-532-PRO-pH-075	ammo::lyser with 7.5m fixed cable, Potassium- and pH-compensation	X		X			X	X
E-532-PRO-pH-000	ammo::lyser with plug connection, Potassium- and pH-compensation	X		X			X	X
E-532-PRO-NO3-075	ammo::lyser with 7.5m fixed cable, Potassium compensation and Nitrate electrode	X	X	X				X
E-532-PRO-NO3-000	ammo::lyser with plug connection, Potassium compensation and Nitrate electrode	X	X	X				X
E-532-ECO-075	ammo::lyser with 7.5m fixed cable	X						X
E-532-ECO-000	ammo::lyser with plug connection	X						X
E-532-ECO-pH-075	ammo::lyser with 7.5m fixed cable and pH-compensation	X					X	X
E-532-ECO-pH-000	ammo::lyser with plug connection and pH-compensation	X					X	X
E-532-ECO-NO3-075	ammo::lyser with 7.5m fixed cable and Nitrate electrode	X	X					X
E-532-ECO-NO3-000	ammo::lyser with plug connection and Nitrate electrode	X	X					X
E-532-ECO-CL-075	ammo::lyser with 7.5m fixed cable and Chloride electrode	X			X			X
E-532-ECO-CL-000	ammo::lyser with plug connection and Chloride electrode	X			X			X
E-532-ECO-NO3-pH-075	ammo::lyser with 7.5m fixed cable, pH- and Nitrate electrode	X	X				X	X
E-532-ECO-NO3-pH-000	ammo::lyser with plug connection, pH- and Nitrate electrode	X	X				X	X
E-532-ECO-CL-pH-075	ammo::lyser with 7.5m fixed cable, pH- and Chloride electrode	X			X		X	X
E-532-ECO-CL-pH-000	ammo::lyser with plug connection, pH- and Chloride electrode	X			X		X	X
E-542-075	fluor::lyser with 7.5m fixed cable					X		X
E-542-000	fluor::lyser with plug connection					X		X

Single electrodes (spare part)	New Version V2	Refurbished Version V2	New Version V1 ¹⁾	Refurbished Version V1 ¹⁾
Ammonium NH4-N	E-533-ISE-NH4	E-633-ISE-NH4	E-532-ISE-NH4	E-632-ISE-NH4
Ammonium NH4-N ²⁾	E-535-ISE-NH4	E-635-ISE-NH4	E-534-ISE-NH4	E-634-ISE-NH4
Nitrate NO3	E-533-ISE-NO3	E-633-ISE-NO3	E-532-ISE-NO3	E-632-ISE-NO3
Potassium K	E-533-ISE-K	E-633-ISE-K	E-532-ISE-K	E-632-ISE-K
Chloride CL	E-533-ISE-CL		E-532-ISE-CL	
Fluoride F	E-543-ISE-F		E-542-ISE-F	
pH	E-533-ISE-pH		E-532-ISE-pH	
Reference	E-533-ISE-ref		E-532-ISE-ref	

¹⁾ Previous version V1 of ammo::lyser (was delivered by s::can until 2006)

²⁾ Current membrane version (delivered since 2018)

The device is typified by a type label, as shown on the right, that contains the following information:

- Manufacturer's name and country of origin
- Several certification marks
- Device name
- Bar code
- Device serial number (S/N)
- Information on power supply
- Acceptable temperature limits
- Environment rating (IP)
- Item number (Type)
- QR code to s::can Support

s::can Made in AUSTRIA



scan Messtechnik GmbH
Brigittagasse 22-24, A-1200



ammo::lyser

Ammonium

10 - 30 VDC

0 - 60 °C

IP68



S/N: 18401000

Type:

E-532-eco-pH-075

- 1** Reference electrode (always slot position 1)
- 2** Ammonium or Fluoride electrode (in most cases slot position 2)
- 3** pH electrode, ISE-electrode or empty (depending on type)
- 4** Potassium or another ISE-electrode or empty (depending on type)
- 5** Temperature sensor
- 6** Cleaning nozzle
- 7** Sensor cable
- 8** Connection for automatic cleaning
- 9** Connection thread for sensor mounting (1½ inch outside)
- 10** Sensor housing



Dimensions of ammo::lyser / fluor::lyser in mm

3.4 Storage and Transport

The temperature limits for device storage and transport, which are described in the section technical specifications, have to be observed at all times. The device shall not be exposed to strong impacts, mechanical loads or vibrations. The device should be kept free of corrosive or organic solvent vapours, nuclear radiation as well as strong electromagnetic radiation.

The reference- and pH-electrode have to be protected from drying out. Drying out of both electrode types will result in reduced measuring quality at the beginning and reduced life span up to complete loss of function (> 48 hours). For wetted storage of the reference and pH-electroden the delivered protective cap can be used. Moreover both electrode types should be stored vertically with the membrane downwards and the plug upwards, to ensure complete wetting of the inside.

For long term storage without reducing the life time of the electrode, a 3 M Potassiumchloride solution (KCl) has to be used. For short term the electrode storage can be done in drinking or tap water (never use distilled or demineralised water!). In this case an aging of the electrode occurs similar to the normal operation.

The Ammonium-, Fluoride-, Potassium-, Chloride- and Nitrate electrode will be stored on air dry. Before initial startup a conditioning is needed.

For information about maximal storage duration please refer to the technical specifications located at the end of this manual.

Damage to the sensor and the electrodes caused by wrong storage will not be covered by warranty.

Transport should be done in a packaging that protects the device (original packaging or protective covering if possible).



This product is marked with the WEEE symbol to comply with the European Union's Waste Electrical & Electronic Equipment (WEEE) Directive 2012/19/EC. The symbol indicates that this product should not be treated as household waste. It must be disposed and recycled as electronic waste. Please assist to keep our environment clean.

3.5 Scope of Delivery

Immediately upon receipt, please check the received consignment for completeness on the basis of the delivery note and check for any possible damage incurred during shipping. Please inform the delivering dispatcher and s::can immediately in case of any damages in transit.

The following parts should be included in the delivery:

- s::can ammo::lyser / fluor::lyser (part-no. E-532-x-0xx or E-542-x-0xx)
- Connection cable (part-no. C-1-010-SENSOR) in case of plug version (-000)
- Tool for electrode replacement (part-no. E-532-TOOL)
- s::can manual ammo::lyser / fluor::lyser (part-no. S-23-M)

The following parts could be included in the delivery if ordered as an option:

- Set for cleaning connection (part-no. B-41-SENSOR)
- Extension cable (part-no. C-210-SENSOR, C-220-SENSOR or C-230-SENSOR)
- Mounting for ammo::lyser / fluor::lyser (part no. F-11-OXI-AMMO)
- Flow cell setup tap water for ammo::lyser / fluor::lyser (part-no. F-45-AMMO)
- Flow cell setup waste water for ammo::lyser / fluor::lyser (part-no. F-48-AMMO)

In case of incompleteness please contact your s::can sales partner immediately!

3.6 Product Updates and Other

The manufacturer reserves the rights to implement, without prior notice, technical developments and modifications in the light of continuous product care.

4 Installation

4.1 Environment

The correct installation of measuring instruments is an important prerequisite for satisfactory operation. Therefore the following checklist for the installation can be used to ensure that all sources for potential operational problems can be ruled out to the greatest possible extent during the installation, allowing the monitoring system to operate properly.

- Favourable flow conditions (little turbulence, acceptable flow rate, pressure, etc.)
- Unadulterated, representative measuring medium
- Measuring medium is in equilibrium state (no gas release, no precipitation, etc.)
- No external interferences (no electric and electro-magnetic interferences by leakage current, earth fault of pumps, electric motors, electric power lines, etc.)
- Easy accessibility (mounting, sampling, functional check, demounting)
- Availability of sufficient space (probe / sensor, installation fitting, controller, etc.)
- Adherence to limit values (see technical specifications located at the end of this manual)

- Power supply for controller (operational reliability, voltage, power, peak free)
- Oil- and particle free compressed-air supply (optional for automatic probe / sensor cleaning)
- Best possible weather and splash water proof conditions
- Shortest possible distances between system components (probe / sensor – controller – compressed-air supply – energy supply)
- Correct dimensioning, mounting and protection of all cables and lines (non-buckling, no risk of stumbling, no damage etc.)

4.2 Installation Notes for ammo::lyser / fluor::lyser



For correct and low-maintenance operation of the sensor please keep the following notes in mind.

- Never hang the sensor into the water on the sensor cable only or pull it out on the cable only.
- Protective caps have to be removed from the reference- and pH-electrode before installation and shall be stored for later storage or shipment.
- Because each measured medium has a different ion composition and ion concentration, the electrodes need time to adapt to the particular medium (conditioning). Therefore storage of the sensorhead (or of the replacement electrodes) in the measured medium is recommended already several hours before initial startup. Too short conditioning time of the electrodes can result in drifting readings.
- The sensor head has to point downwards when installed. This ensures that no air bubbles inside the electrode will falsify the measured readings. Air bubbles that accumulate on the membrane (both inside and outside) will lead to false, sometimes unstable or jumping readings.
- To remove air bubbles inside the electrodes caused by transport or handling, the sensor has to be knocked onto a flat and hard surface several times carefully straight before installation or any reinstallation (see figures on the right).

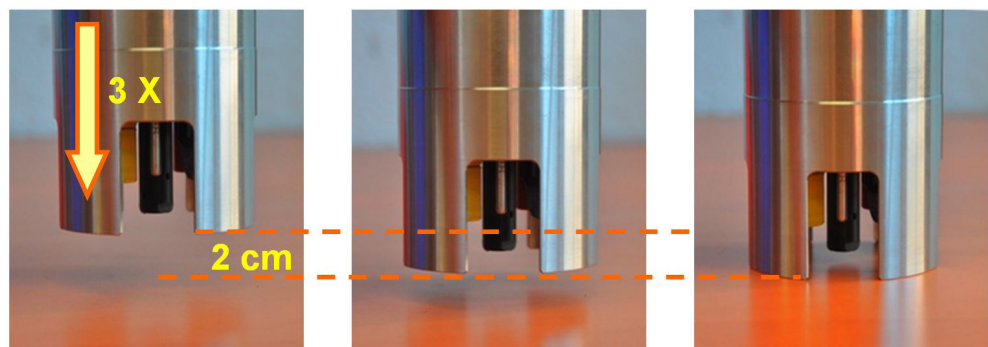

4.3 Mounting with Sensor Carrier

This section explains how the ammo::lyser / fluor::lyser can be installed in the sensor carrier (part-no. F-11-OXI-AMMO). Regarding the dimensions of this installation accessories please refer to section 11.1.3.

The installation of the sensor with this carrier is performed by the following steps:

- Separate the sensor carrier into different parts by unscrewing the union nut [2].
- Fix the insert part of the sensor carrier without thread [1] to the extension pipe [4] (OD 50 mm or 1 $\frac{1}{2}$ inch - has to be provided by customer) firmly (e.g. using a PVC glue).
- Lead the sensor cable and the air hose for automatic sensor cleaning through the sensor carrier.
- The part of the sensor carrier with double thread [3] will be screwed on top of the sensor (cable side).
- Lead the sensor cable and the air hose for automatic sensor cleaning through the prepared extension pipe.
- Mount the ammo::lyser / fluor::lyser onto the sensor carrier with the extension pipe using the union nut [2].

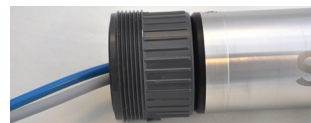

4.4 Mounting in Flow Cell

The following sections explain how the ammo::lyser / fluor::lyser can be installed in a flow cell. There are two types of flow cell available, one for tap water (part-no. F-45-AMMO) and one for waste water (part-no. F-48-AMMO). For both flow cells a specific adapter has to be mounted onto the ammo::lyser / fluor::lyser (see section 4.4.1). Regarding the dimensions of these flow cells please refer to section 11.1.4 and 11.1.5.

4.4.1 Mounting Adapter of Flow Cell

The mounting of the flow cell adapter on the sensor is performed by the following steps:

- Unscrew both slotted screws [1] from the measuring head. Do not screw out the red, sealed, hex socketed screws.
- Place the adapter [2] over the measuring head. Align the holes for the fixing screws with the holes in the sensor (see yellow mark in the figure below). Also ensure the correct fit of the o-ring sealing.
- Fix the sensor with two flat head slotted screws [3] which are included in the delivery of the flow cell setup.

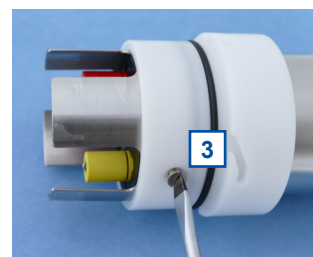
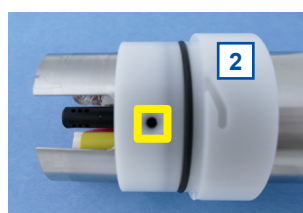
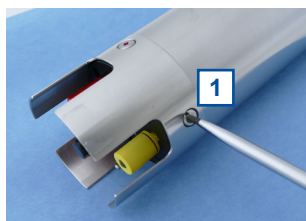
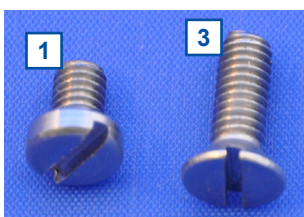

4.4.2 Mounting in Flow Cell for Tap Water

The following parts are included in the delivery of the flow cell F-45-AMMO:

- 1** Flow cell for tap water
- 2** Adapter for flow cell
- 3** 2 screws for adapter mounting
- 4** 2 fixing holders for panel mounting
- 5** Metal bracket for flow cell fixation on panel



Once the flow cell adapter is fixed on the sensor (see section 4.4.1) the installation of the flow cell is performed by the following steps:

- Place the sensor in the opening of the flow cell in that way, the grooves of the flow cell adapter are aligned with the four metal pins of the flow cell (see yellow mark in the figure on the right).
- Now push the sensor down and turn it clockwise to fix it into the bayonet lock.
- If needed the flow cell can be mounted onto an s::can panel or a flat wall using the 2 fixing holders and the metal bracket.



4.4.3 Mounting in Flow Cell for Waste Water

The following parts are included in the delivery of the flow cell F-48-AMMO:

- 1** Flow cell for waste water
- 2** Adapter for flow cell
- 3** 2 screws for adapter mounting



Once the flow cell adapter is fixed onto the sensor (see section 4.4.1) the installation of the flow cell is performed by the following steps:

- Place the sensor in the opening of the flow cell in that way, the grooves of the flow cell adapter are aligned with the four metal pins of the flow cell (see yellow mark in the figure on the right).
- Now push the sensor down and turn it clockwise to fix it into the bayonet lock.



4.5 Connection of automatic Cleaning

The compressed air connection set (B-41) contains components necessary to connect the sensor cleaning located on top of the ammo::lyser / fluor::lyser to the cleaning valve. The compressed air connection is performed by the following steps (see figures below also):

- Remove dummy insert [1] from pressure connection on top of the sensor by unscrewing the union nut [2] and removing the conical part [3].
- Put the union nut [2] and the conical part [3] over the cleaning hose.
- Push the cleaning hose over the pressure connection (warm up with hot water if necessary).
- Fasten union nut [2] by hand.



The connection to the cleaning valve depends on the used type of cleaning valve.

■ Cleaning valve B-44

A compressed air hose (to be provided by customer, ID 8 mm to 9 mm, UV- / ozone resistant) must be used to connect the adapter fitting of the pressure connection set to the output side of the cleaning valve (marked with A). Fasten the air hose with hose clamps.

Another air hose and DIN 7.2 compressed air coupling are required to hook up the compressed air supply to the input side of the cleaning valve (marked with P).

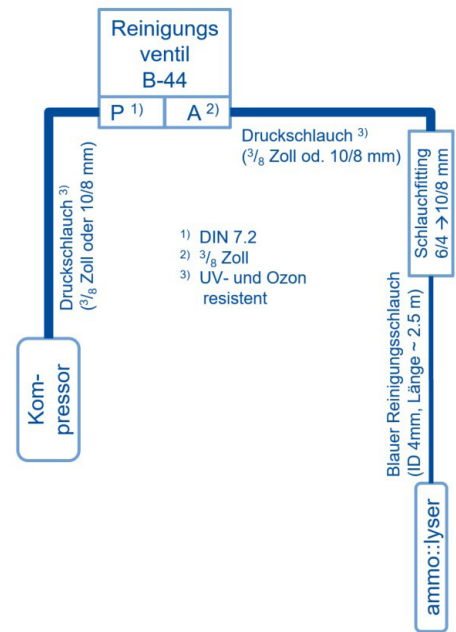

■ Cleaning valve B-44-2

The adapter fitting of the pressure connection set can be removed to connect the blue tube directly to the push-pull fitting of the cleaning valve. The same type of tube can be used to connect the cleaning valve to the s::can compressor.

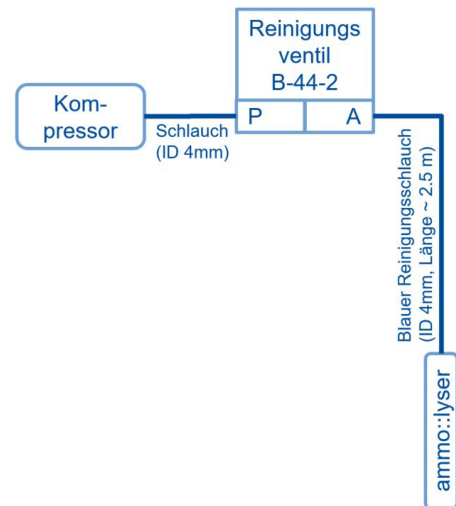

The cleaning valve should never be connected to the compressed air coupling of your compressor directly, i.e. without a pressure hose in between. The total length of hoses should be as short as possible to avoid unnecessary pressure loss. In special occasions, drinking water may be used to operate the hydraulic-pneumatic cleaning appliance instead or compressed air.

Any foreign matter in the compressed air supply may impair the hydraulic-pneumatic cleaning process. If you have any doubts about the purity of the air used (contamination by particles, oil, etc.), please install an appropriate filter upstream from the solenoid valve.

In areas with extremely low ambient air temperature, s::can recommends laying the compressed air hoses such that they remain frost-free to prevent freezing of condensed water in the compressed air hose.

Please note that depending on the s::can probe and sensor type you are using, different maximum allowed pressures may be specified. In case a central pressurised air supply is used in such a case the lowest maximum allowed pressure amongst those specified for the individual instruments is to be used to supply all instruments or the use of pressure reducing valves to supply each instrument with the correct pressure is necessary.

In order to ensure proper operation of the automatic cleaning s::can highly recommends to use s::can compressor optimized for compressed air supply of all probes and sensors.

5 Initial Startup

Once the assembling, mounting and installation of the sensor have been completed and checked (see chapter 4) the initial startup of the s::can monitoring system will require the following actions, in the order presented below:

- Connect the sensor to the controller used for operation (see section 5.1 and 5.2).
- Establish power supply to the controller (please refer to the manual of the controller) and wait until the operation software has started up.
- Perform initialisation of the sensor. Refer to section 5.3.1 in case of using a con::lyte D-31x, refer to section 5.3.2 in case of using con::lyte D-320 and refer to section 5.3.3 in case of using con::cube with moni::tool.
- Perform parameterisation of the sensor. Refer to section 5.4.1 in case of using a con::lyte D-31x, refer to section 5.4.2 in case of using con::lyte D-320 and refer to section 5.4.3 in case of of using con::cube with moni::tool.
- Configure the measuring interval; additional information can be found in the respective manual of the controller.
- If required, configure the digital, analogue and fieldbus outputs of the controller.
- Check the readings obtained for plausibility after sufficient running-in time (see section 12 regarding running-in time).
- If required, calibrate the readings of the sensor in stable water quality (see chapter 6).

5.1 Controller for Operation

For proper operation of the sensor you will need one of the following controller and operating software respectively.

Controller	Type	Software
con::lyte	D-318, D-319	V5.01 or higher
con::lyte	D-320	V7 or higher
con::cube	D-315	moni::tool V2 or higher



s::can recommends to use the most current version of the operating software on the controller. For service operation with ana::pro please refer to section 10.4.2.

5.2 Connection to the Controller for Operation

The sensor will be delivered either with fixed cable or with a plug connection on the sensor itself. In case of plug connection the connection cable C-1-010 has to be used to connect the sensor to a compatible socket provided on the controller. Ensure that the sensor plug and the connector are dry and clean. Otherwise communication errors and / or device damage might occur.

In case the controller does not supply enough sockets, the distribution box for sensors C-41-HUB can be used.

5.3 Probe Initialisation

For operating one or several probes using one operation terminal it is necessary to allocate an individual address to every probe. This can be done during probe initialisation at which the probe has to be recongnized first by the ontroller for operation and then a modification of the actual (preset) probe address might be performed. The corresponding address will be stored on the respective probe. For s::can probes and sensors of the same type the same address is preset ex factory.

5.3.1 Probe Initialisation using con::lyte D-31x



The con::lyte should not be powered down or switched off during the initialisation process. In case of rebooting of the con::lyte during the initialisation process (e.g. caused by loss of power supply) the complete procedure of probe initialisation has to be repeated.

- Establish the power supply to the con::lyte and select entry Settings / Parameter settings / Install Probes in the main menu.
- Connect the sensor to the con::lyte (see section 5.2).
- Push the button Enter, which starts the automatic search procedure for the connected probe. Once the probe is found, address 1 will be allocated. This procedure can last several seconds (see figures below).
- The successful completion of the initialisation will be displayed over a user message. If this message is displayed the initialisation procedure can be finished by pushing the button Esc.

```
Install probe 1
Connect only
probe 1
Continue with ENTER
Stop with ESC
```

```
Install probe 1
Searching for probe
```

```
Install probe 1
Probe search finished
ammo::lyser found
Continue with ENTER
Stop with ESC
```

A user message will also be displayed when no sensor is detected. In this case please check the following before repeating the procedure for probe initialisation:

- Is only one sensor connected to the con::lyte?
- Is the sensor connected properly?
- Are all wires of the con::lyte socket in the terminal compartment tight?

```
Install probe 1
Probe search finished
No probe found
Continue with ENTER
Stop with ESC
```

5.3.2 Probe Initialisation using con::lyte D-320

At the initial start-up the con::lyte D-320 provides an automatic probe and sensor initialisation procedure (see screen on the right). After connecting all probes and sensors to the appropriate plugs of the con::lyte (see section 5.2) and pushing the OK button, the probe and sensor initialisation starts.

```
Add s::can sensor...
Please connect all
sensors and press
OK to continue...
```

If sensor will be initialized at a later date, the following steps are needed:

- Switch to Status display by using the Left- or Right button.
- Push Function button, select menu Manage sensors... and confirm with OK.
- Select menu Add sensor... and confirm with OK.
- Connect sensor to the D-320 (see section 5.2).
- Select menu Add s::can sensor... and confirm with OK.

```
Add new Sensor
Add 0/4-20mA...
Add digital in...
Add s::can sensor...
```

As soon as the entry is confirmed by pushing the OK button, the con::lyte will automatically search the Modbus port for a new sensor and will add the new sensor to the sensor list.

```
Add s::can Sensor...
Searching 17/20
F: ammo::lyser/0/9
A: ammo::lyser/0/9
```

After adding a new probe or sensor, the parameters will be displayed in the parameter screen. Furthermore single parameter can be added manually (see section 5.4.2 and menu Add parameters...). In case the installation failed, the message Error adding! will be displayed.

```
Add s::can Sensor...
Done. Press OK...
Added sensors: 1
Replaced sensors: 0
```

5.3.3 Probe Initialisation using moni::tool

- Click the Service tab of the moni::tool screen and logon as Administrator.
- Click on an empty sensor icon (Add new Sensor) to initiate the initialisation process.

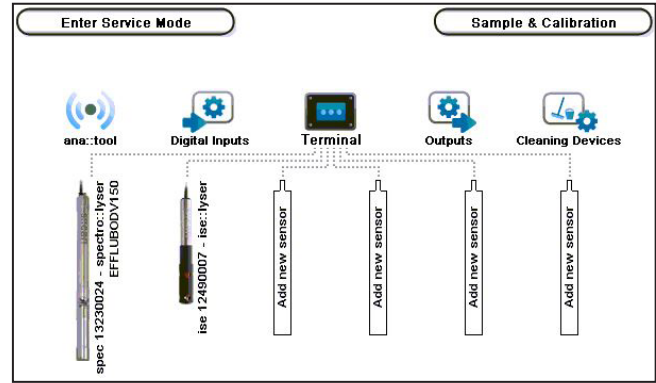

- An automatic search procedure will start, searching for the connected sensor.

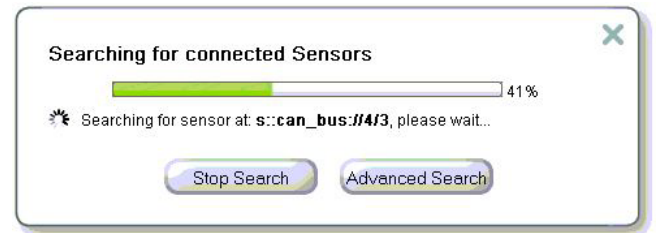

- When the automatic search procedure is finished, moni::tool will display all connected probes and sensors. Those sensors that are connected for the first time will have the Status Found new sensor (also listed as New Sensors below).

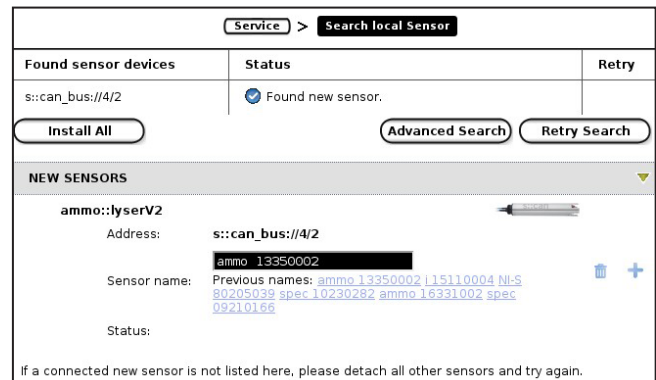

- If needed Sensor name can be modified now, which can be any descriptive name you desire or select one of the previous names listed below this entry field.

- To install the new sensor click on the blue \pm sign on the right side of the sensor or push the button Install All.

- moni::tool will install the sensor and switch to the Service tab showing the new sensor in the system overview. Now pushing the button Leave Service Mode located on the upper left side to start the measuring process.

- When pushing the button Advanced Search (see 2nd and 3rd figure from the top), the method you connected the sensor (Connection methode), the used COM-Port and the Address can be defined. A click on button Start search will start search procedure within the defined range.

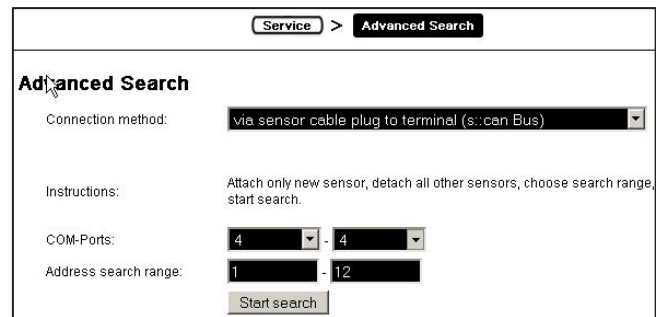

- After the Advanced Search is finished, the Install Sensor screen is displayed. Depending on the used Service Level (Basic, Advanced or Expert) only the basic or all information received from the sensor are listed up.



- To install the new sensor push the button Save in the upper part of the window.

5.4 Probe Parameterisation

An overview of the parameters that can be measured with the different types of ammo:lyser / fluor::lyser can be found in section 3.3.

5.4.1 Probe Parameterisation using con::lyte D-31x

After successful probe initialisation (see section 5.3.1) the measuring parameters of the ammo:lyser / fluor::lyser will be displayed on the display of the con::lyte automatically. If needed the measuring parameters can be configured individually using the menu item Settings / Parameter settings / Parameter n (Settings / Parameterconfig / Parameter n with older versions).

The name of the Probe or sensor used as a source of the parameter is displayed in the upper line (e.g. ammo:lyser). If several probes or sensors are installed the instrument from which a parameter needs to be displayed can be selected here. Under the entry Probe the Address that has been allocated to that probe is displayed as an additional information. The Index specifies the place of the corresponding parameter onto the allocated probe. The Unit of the selected parameter is displayed in the line below. The item Decimal places enables settings of the number of displayed decimal places (between 0 and 4). With the default setting auto the number of decimal places will be automatically set by the sensor.

Parameter 1	
Probe:	ammo::lyser
Address:	1
Index:	0
Unit:	mg/l
Decimal places:	auto

5.4.2 Probe Parameterisation using con::lyte D-320

After successful probe initialisation (see section 5.3.2) the needed measuring parameters of the ammo:lyser / fluor::lyser have to be added to the parameter display. This is performed by the following steps:

- Switch to status display with Left- or Right button.
- Push Function button, select menu Manage sensors... and confirm with OK.
- Select ammo::lyser/0/x and confirm with OK.
- Select menu Add parameters... and confirm with OK.
- Select needed parameter and confirm with OK.

Add para.	
▶ Add	NH4-N
Add	Temp.

The selected parameter will be displayed now on the next free position of the parameter display. The default display configuration is used. Changing the display format is performed by the following steps:

- Select the parameter in the parameter display using Up- or Down button.
- Push Function button, select menu Display settings... and confirm with OK.
- Select ammo::lyser/0/x and confirm with OK.
- Select menu Add parameters... and confirm with OK.
- Select needed parameter and confirm with OK.

In the displayed parameter configuration the following settings can be modified.

- Name Displays the actual name of the paramter.
- Unit Displays the actual unit of the paramter.

P2/Temp	
Name:	Temp
Unit:	°C
Disp.Format:	1
Load Defaults	

To change the name or unit of the parameter, select the entry with Up- and Down buttons and by pushing the OK button the name can be changed with Up-, Down-, Left- and Right buttons. Pushing the OK button confirms the new name.

Please note that change of parameter name or unit will not change the parameter configuration itself (e.g. if you change the parameter name NO₃-N to NO₃ the reading will still be NO₃-N).

- Disp.Format Within this line the number of displayed decimal places (between 0 and 5) can be set. Please note that in case of too many digits high values can not be displayed and the parameter reading will switch to plus signs (++,+++++).
- Load Defaults Confirming this entry by pushing the OK button will restore the default display settings from the sensor.

All modifications performed by the operator within these settings menu will be documented in the configfile of the con::lyte (see manual con::lyte D-320).

5.4.3 Probe Parameterisation using moni::tool

After successful probe initialisation (see section 5.3.3) all parameters available on the probe will be installed and automatically displayed on the *Value* screen of moni::tool. If not all new parameters are displayed, please check the maximum number of parameters of your moni::tool license. If you want to configure the measuring parameters individually this can be done using the menu item *Service / Terminal / Parameter*.

After selecting that menu item a list of all installed parameters is displayed. After selecting one or several parameters by clicking on them the following activities can be performed:

- Moving the selected parameter to a higher position in the *Value* display by pushing the entry *Up*.
- Moving the selected parameter to a lower position in the *Value* display by pushing the entry *Down*.
- Deleting the selected parameter from *Value* display by pushing the entry *Remove Parameter*.
- A new parameter can be added by pushing the entry *Add Parameter*.
- Click on the blue wheel (*Edit*) on the right hand side of the parameter will display the actual parameter settings. Depending on the actual *Service Level* different settings are displayed and can be edited. *Parametername*, *Unit* and *Resolution* can be modified in the *Basic* level.
- On a higher *Service Level* (*Advanced*, *Expert*) the *Additional Parameters* can be configured.
- Click on the blue check mark (*Config*) on the right hand side of the parameter to check or modify the settings for vali::tool of this parameter. The *Basic* screen is displayed on the right. Please refer to the manual moni::tool for further information.
- Click on the next blue sign (*Alarm*) on the right hand side of the parameter to check or modify the alarm settings for this parameter. The basic screen is displayed on the right. Please refer to the manual moni::tool for further information.

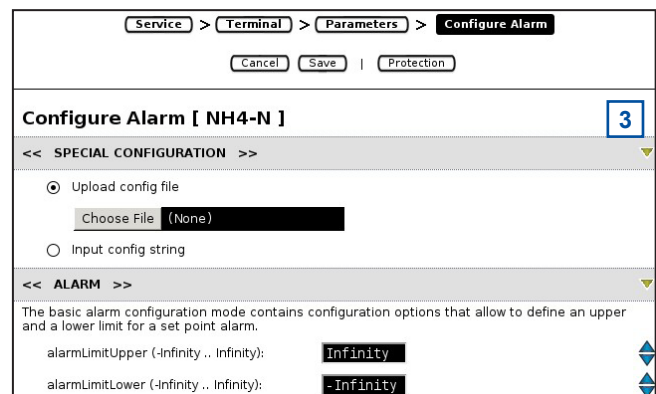
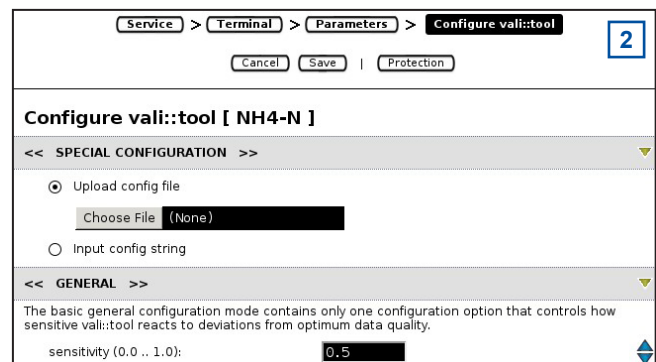
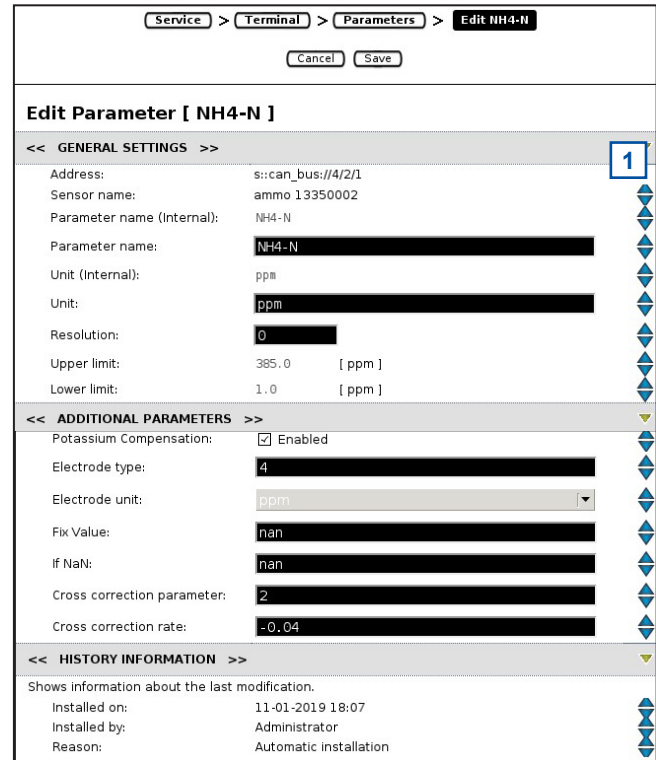
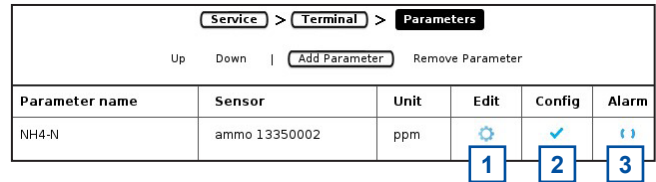

6 Calibration

The ammo::lyser / fluor::lyser is equipped with quality certified measuring electrodes and ready for use. Because the electrodes have to adapt to the composition of the measured medium (background matrix), a certain time for conditioning is needed (see technical specifications). As soon as the measurement is stable, a matrix adaption (local calibration) can be performed if needed.

6.1 Types of Calibration

The ammo::lyser / fluor::lyser is equipped with a global calibration (factory setting) for each installed electrode. A reset to this global calibration is possible at any time. The table below can be used as assistance, to decide which calibration type shall be used:

Global Calibration	Local Calibration	
	Offset Calibration with 1 Sample	Linear Calibration with 2 Samples
<ul style="list-style-type: none"> ■ At initial startup ■ During conditioning ■ After electrode replacement ■ In case of failed (not accepted) linear calibration 	<ul style="list-style-type: none"> ■ At initial startup, in case reading does not correlate with reference value after completed conditioning (matrix adaption). ■ If sensor displays zero, although concentration in measured medium is > 0.3 mg/l ■ If sensor displays stable reading > 0.3, although concentration in measured medium = 0. ■ During routine functional check to adapt the reading to the reference value. ■ If readings are drifting to higher concentrations. ■ After electrode replacement, in case reading does not correlate with reference value after completed conditioning and activated global calibration. 	<ul style="list-style-type: none"> ■ If reading correlates with reference value at lower concentrations, but differs at higher concentration. ■ If higher accuracy of measurements is required. ■ If measurement range shall be changed. ■ When the electrode is aged, but shall not be replaced yet (adaption of electrode slope).

6.2 Notes for Calibration Procedure

- The local calibration can be performed either directly in the measured medium without removing the sensor from the installation place (recommended) or outside in a beaker (min. 250 ml) with calibration solution.
- First the temperature, then pH and Potassium and finally the other ISE electrodes shall be calibrated.
- Before performing any kind of calibration ensure appropriate conditioning time of the sensor (see technical specifications).
- Before performing a local calibration ensure the correct function of the sensor (see section 8).
- During calibration ensure that the complete measuring head (i.e. all electrodes) are submersed into the measuring medium and protective caps are removed.
- The temperature sensor can be calibrated on air or in the measuring medium towards a reference thermometer.
- If a linear calibration was performed outside the measuring medium successfully and there is still a difference between the real concentration in the measuring medium and the sensor reading after installation, an offset calibration shall be performed directly in the measuring medium additionally.

A local calibration is performed by the following steps:

- 1** Check sensor readings:
 - Check on the controller for operation, if the sensor readings are stable (no jumps, no scattering, no drift) for at least 5 consecutive measurements.
 - Open calibration menu and wait until displayed quality number is > 0.9.
- 2** Take sample & store actual reading:
 - Push button *Sample* to store the actual reading on the sensor. The previous sample value will be overwritten.
 - Take a sample for reference measurement at the same time close-by the measuring electrode.
 - Now you can switch the controller for operation back to normal measuring mode.
- 3** Analyze reference sample:
 - If required, filtrate and stabilise the reference sample.
 - Analyse the reference sample as soon as possible.
- 4** Performing local calibration:
 - Open calibration menu on controller for operation.
 - Enter the reference value of the appropriate sample.
 - Check if the desired calibration type (offset, linear) is selected.
 - Perform the calibration by pushing the calibrate button.
- 5** Check sensor readings:
 - Wait if any error message is displayed.
 - Wait for next measurement.
 - Check if reading is plausible and no status error is displayed.

6.3 Special Notes for Calibration of ISE Electrodes

Ion type, ionic strength and other characteristics of the measuring medium will significantly affect the results obtained with the ion selective electrodes. For highest accuracy the same environment conditions (temperature, flow velocity, pH) shall be ensured during the calibration procedure like during the normal operation. Therefore it is recommended to perform calibration directly in the measured medium with sensor installed. Ideally, two samples are used which were taken at different times, and represent the high and low values of the measuring range that is expected in the application.

If standard solutions are needed for calibration, never use normal standards ready for use, because these are made with distilled water and will never represent a natural ion background matrix. Standard solutions can be made quickly and easily with the real measured medium or drinking water by adding high concentrated standards (spiking).

The table on the right shows a selection of possible standards that can be used for spiking the samples.

Name	Concentration ¹⁾
Ammonium Standard Solution	1000 mg/l NH ₄ -N
Potassium Standard Solution	1000 mg/l K
Nitrate Standard Solution	1000 mg/l NO ₃ -N
Chloride Standard Solution	1000 mg/l Cl
Fluoride Standard Solution	1000 mg/l F

- The samples used for a two point calibration should represent the total measuring range, but the concentration difference must not be more than a factor 100.
- As a general rule sample 1 should be approx. 2.5 % and sample 2 should be approx. 90 % of the max. measured concentration.
- The upper measuring range will be redefined by a linear calibration (higher lab value + 10%). Higher values will be displayed but System Status will be set to Warning. That means, if high sample with NH₄-N = 18 mg/l is used, the upper measuring range will be 18 + 10% = 19.8 mg/l.

¹⁾ The Ammonium concentration of 1 liter sample can be increase by 10 mg/l by adding 10 ml of standard.

Within the table below you will find two further examples for sample spiking with 1000 mg/l standard:

Sample 1	Concentration	Standard added	Concentration of Sample 2	New Measuring Range
1.0 liter	0.3 mg/l	5 ml	5.3 mg/l	0 - 5.83 mg/l
0.5 liter	2.8 mg/l	10 ml	22.8 mg/l	0 - 25.08 mg/l

The local calibration is applied to the raw value (mV readings) and not to the calculated concentration (mg/l value). The correlation between mV and mg/l value is not linear but logarithmic. That means performing an offset calibration will not change the mg/l readings by a constant factor. The two figures below are showing the effect of an offset calibration.

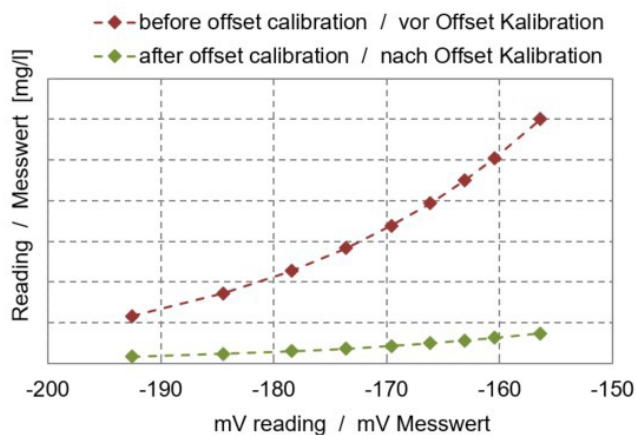
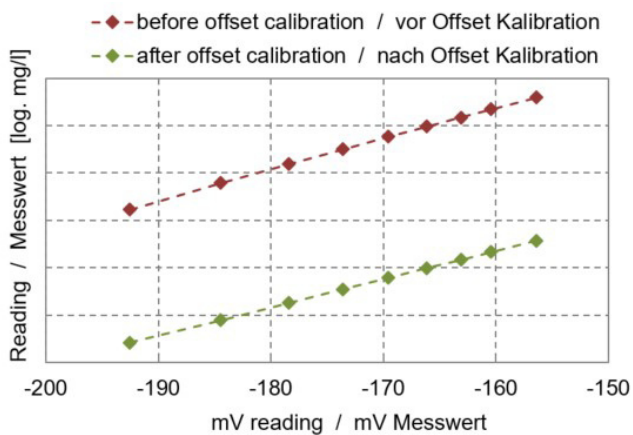

6.4 Performing a Calibration

6.4.1 Calibration using con::lyte D-31x

The Calibration entry in the con::lyte main menu leads you into the menu that enables the calibration of the sensor. When Calibration is selected a password must be entered (password = 1) before the calibration can be started. The next step is selection of the parameter to be calibrated (e.g. NH4-N) in the selection field Parameter Calib.

Parameter Calib.	
Local cal.:	NH4-N
Local cal.:	K
Local cal.:	pH
Local cal.:	Temp

Now the menu for local calibration will appear. As long as the sensor is working with factory calibration (default) the entry Calib. shows global and no Type can be selected (as displayed on the right hand side). The entry Calibrate! has to be confirmed by pushing Enter if the actual used local calibration shall be replaced by the global one.

Local cal.: NH4-N	
Calib.:	global
Type:	None
Calibrate!	

To perform a local calibration the entry Calib. has to be changed from global to local. Then below the entry Type will show Offset as one possible type of calibration. The Type can be changed to Linear also.

Local cal.: NH4-N	
Calib.:	local
Type:	Linear
Value:	3.27
Quality:	0.93
Sample 1:	-156.64
Lab 1:	3.6
Sample 2:	--.--
Lab 2:	--.--
Calibrate!	

The display shows the sensor reading of the parameter actually measured and displayed (Value) as well as the quality number of this reading (Quality). The quality can vary between 0 (bad) and 1 (perfect) and should be > 0.9 when storing the displayed value as a sample.

In the next line the parameter concentration stored on the sensor as first sample for offset calibration (Sample 1) is displayed. As long as no sample is stored on the sensor the display will show dashes. When confirming the entry Sample 1 by pushing Enter the raw signal of the actually measured (displayed) parameter concentration will be stored as new sample on the sensor.

On the entry Lab 1 the result (real parameter concentration) corresponding to the reading stored under Sample 1 can be entered here.

Only if calibration type linear is selected, the values for Sample 2 and Lab 2 are visible on the display and can be modified.



When the entry Calibrate! is confirmed by pushing Enter, the calibration is performed. Successful calibration is shown in a user message (Please wait and then Local calib. saved). If the calibration was not successful (user message Local calib. Error!) the previous calibration will be used further on.

6.4.2 Calibration using con::lyte D-320

This operating controller provides, beside normal calibration procedure (see further down), the possibility for a quick calibration call directly from the parameter view. This is performed by following steps:

- Select the parameter in the parameter display with Up- or Down button.
- Push OK button, which directly displays the calibration screen.
- Select Sample 1 and confirm with OK to store the raw signal of the actual reading.
- Take a water sample to analyse real parameter concentration.
- Enter the result from laboratory analyse into the field Lab 1.
- Select entry Perform Calibration and confirm with OK.
- Leave the calibration screen with Back button.

< V	P1/4	MH4-N	>
▶	1.02	NH4-N	
		ppm	
	18.7	Temp	
		°C	

P1/NH4-N	
Lab 1:	1.62
Sample 1:	78.11
Perform Calibration	

The advanced local calibration provides extensive possibilities for calibration of measurement parameter. After selecting the parameter in the parameter display, pushing the Function button, selecting the menu Calibrate expert... and pushing the OK button, the calibration screen is displayed.

- Type Two different types of calibration are available: Local or Global. By default Local is selected. This is the normal calibration performed by the operator. As soon as Global is selected and confirmed with OK a reset of this parameter to factory calibration is performed and the actual reading (Value), the raw signal (Private) and the default offset (Offset) will be displayed.
- Mode As available local calibration variants either Offset or Linear can be selected.
- Perform Calibration Confirming this entry by pushing the Ok button will execute the local calibration, using the Lab and Sample values displayed on the calibration screen.
- Value Displays the measured value of the sensor like on the parameter screen also (i.e. using the actual calibration). The value will be updated permanently.
- Private Displays the quality number of this reading. The quality can vary between 0 (bad) and 1 (perfect) and should be > 0.9 when storing the displayed value as a sample. The value will be updated permanently.
- Lab 1 Within this line the correct value for the measured Sample 1 has to be entered. The entered Lab value can be either the laboratory result of the sample taken or the concentration of the standard solution, which is used for calibration. The unit of the lab value has to be in accordance with the measuring parameter.

P1/NH4-N	
Type:	Global
Value:	1.02
Private:	9.74
Offset:	10.00

P1/NH4-N	
Type:	Local
Mode:	Linear
Perform Calibration	
Value:	1.02
Private:	0.94
Lab 1:	25.3
Sample 1:	-65.8
Lab 2:	--.--
Sample 2:	--.--
Offset:	0.0
Slope:	6.00

An entered Lab value can be deleted by selecting it and pushing the Function button so that it will not be used in the calibration.

- Sample 1 When confirming this entry by pushing the Ok button, a measurement will be performed and stored as sample 1 for the local calibration. The sample for the laboratory should be taken at the same time. The displayed and stored value, which will be used for the calibration might be a raw value (e.g. mV value) and therefore might also be negative.

Existing readings (Sample 1 or Sample 2) are overwritten whenever a new measurement was performed or if the measurement was invalid, the message Measure! will be displayed instead of a numerical value.

- Slope Displays the used slope of the actual calibration. It is not possible to edit this value.

6.4.3 Calibration using moni::tool

- 1 Click the Service tab on the moni::tool screen.
- 2 Logon as Administrator with password admin1 or your individual username.
- 3 Click the icon of the sensor you want to calibrate in the displayed system overview.
- 4 Click the icon Calibrate sensor in the next screen.

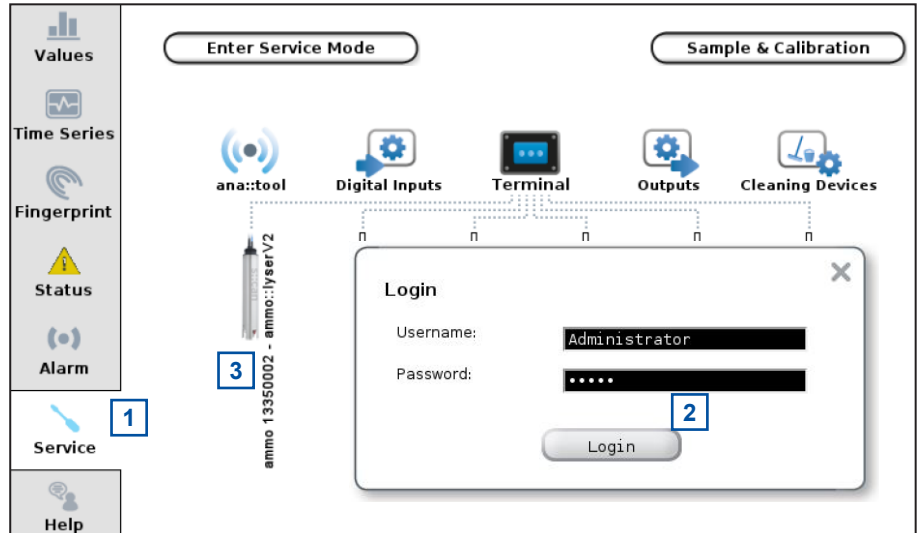

Now the screen shows a list of all parameters being measured by this sensor (Parameter name).

- 5 Clicking on the blue triangles will open more information about actual used calibration for this parameter.
- 6 Furthermore a click on the History icon rightmost opens a logbook showing all up to now with this con::cube performed calibration procedures.
- 7 Open the calibration screen by clicking on the Calibrate icon on the right side of the parameter you want to calibrate.

Service > ammo 13350002 > Calibration				
Parameter name	Last calibration		Calibrate	History
NH4-N	Administrator [Offset]	▲▼	<input type="checkbox"/>	<input type="checkbox"/>
pH	Name [Linear] Coefficient 0 - Offset: 0.2221 Coefficient 1 - Slope: 74.4228	▲	<input type="checkbox"/>	<input type="checkbox"/>
Temperature	Administrator [Global]	▲▼	<input type="checkbox"/>	<input type="checkbox"/>

- 8 This button displays the actual used calibration (Global, Offset or Linear). Push this button to select the type of calibration you want to perform.
- 9 Watch the current readings and the quality being displayed numerically and graphically on the calibration screen. Wait until readings are stable (Quality OK).
- 10 Push the Sample icon to store the actual reading on the sensor. Please note that the displayed value is the raw value (mV reading).
- 11 Push the Edit icon to enter the result of the laboratory analysis and store it on the sensor.
- 12 Push the button Perform calibration to start the calibration procedure.

Service > ammo 13350002 > Calibration > Calibrate NH4-N

Status View | Perform calibration

Calibrate NH4-N [ppm] Offset

Current value: 20.32 ppm Quality factor: 0.84

<< STATUS >>

Parameter: OK Quality: ERROR

<< SAMPLES >>

#	Sample	Measured	Laboratory	Edit
1	<input type="checkbox"/>	91.665 mV	20.00 ppm	<input type="checkbox"/>

<< CURRENT COEFFICIENTS >>

Name	Value

- After pushing the *Perform Calibration* button an individual name can be entered to describe the calibration (*Calibration name*).

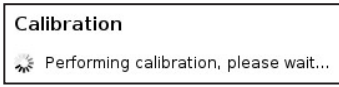

- During the calibration process a message is displayed on the screen (see figure on the left).

- After the calibration procedure is finished a user message will inform the operator, if the local calibration was successful (see figure on the right) or not (see figures below).



The calculated *Slope per decade* will be displayed in case of a linear calibration. This might help to judge the electrode quality (see section 8.5).

- If the offset of the local calibration is incorrect or the slope is too low, the displayed user message will look as shown on the right.

- If the slope of the local calibration is too high, the user message will look as shown on the right.

- If several calibration failures have occurred, all of them will be displayed in the user message (see figure on the right).



In case a *Sensor status error / warning* is displayed, the performed local calibration will be refused and the ammo::lyser / fluor::lyser will stay unchanged.

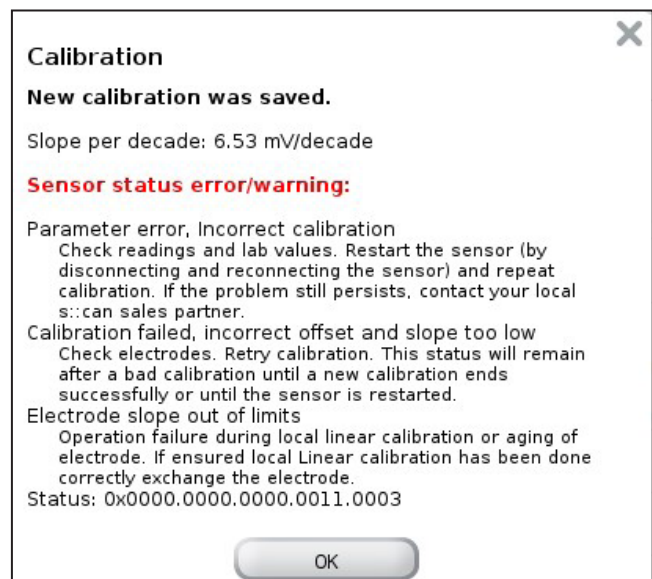
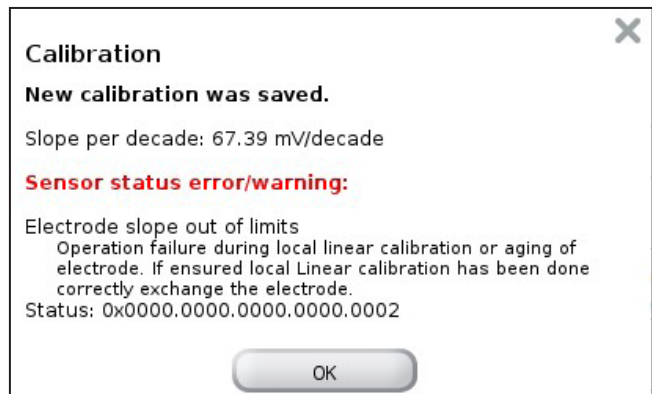
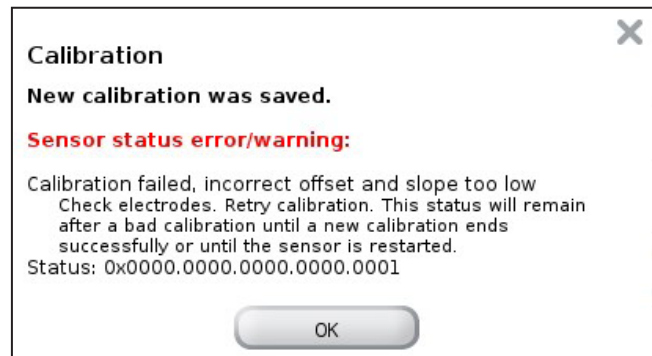

7 Data Management

7.1 Data Storage

The following information is stored directly on the sensor:

- Result of offset or linear calibration
- Factory settings (Global Calibration)
- Two measured samples and the according reference values for comparison
- Information for compensation
- Device information (e.g. electrode type for each slot, serialnumber, address, please refer to section 10.3)

The sensor readings can be stored on the controller used for operation. There is no possibility to store readings on the sensor itself.

7.2 Data Transfer

The measurements are performed on the sensor and the readings are transferred to the controller used for operation via the sensor cable using RS 485.

The reading can be transferred from the sensor either as parameter concentration [e.g. mg/l] or as raw value [mV]. Transfer and storage of mg/l and mV at the same time is not possible.

7.3 Data Visualisation

For visualisation of the sensor readings one of the following s::can controller can be used:

- con::lyte
- con::cube
- con::nect with PC

8 Functional Check

A functional check might be required for one of the following reasons:

- Initial startup
- Routine functional check
- Suspicion of monitoring system malfunction
- Modification of monitoring system (e.g. integration of additional sensor or device)
- Change of measuring location

Depending on the application (water composition), the probes and sensors connected and the environmental conditions a regular functional check (weekly to monthly) is recommended. The following sections provide an overview of all the actions that have to be performed to check the monitoring system quickly (see section 8.1), to check the plausibility of the collected readings (see section 8.2) and to check the integrity of a single probe or sensor (see section 8.3). Finally sections 8.4 and 8.5 explain how to check the measurement accuracy and the electrode aging.

8.1 Check of Monitoring Station

Check	con::lyte	moni::tool / con::cube	What to do if check failed
Power supply controller	Green LED is on? Text is visible on the display?	LED on housing cover is on or at least flashing? moni::tool screen is displayed after touching the screen?	Check power supply of controller. Power off controller for 5 minutes and power on again.
System running (up-to-date)	Displayed system time is current and is updated every second?	Click on system clock at the bottom of the screen shows current time and last measurement. Both are current?	Check for displayed error messages. Check if Service mode is acitvated or automatic measurement is paused.
System status	No error messages or error symbols are displayed?	LED of con::cube is blue and <i>Status</i> icon of moni::tool is not blinking yellow?	See section 10 for Troubleshooting.
Reason for bad system status	Check logbook entries since last functional check.	Open <i>Status</i> tab and select symbol of affected sensor for more information.	See section 10 for Status- and Errorcodes.

Check	Remark
Function of automatic cleaning	Use function <i>Clean now</i> or wait for next cleaning cycle. Watch for air bubbles when cleaning is activated.
Compressed air supply for automatic cleaning	All tubes and fittings are tight?
Function of compressor and storage tank	Drain condensed water from storage tank of compressor (not necessary for s::can compressor B-32). Check pressure.
Monitoring station (by-pass)	All tubes and fittings are tight and all probes and sensors are supplied with medium? No air bubbles within the tubes?
Installation submersed (in-situ)	Mounting equipment of all devices is ok and all probes and sensors are submersed?
Data transfer	Check if displayed readings on local controller are equal with displayed readings on customer display system.

8.2 Check of Readings

Check	con::lyte	moni::tool / con::cube	What to do if check failed
Current readings displayed completely	No <u>NaN</u> and no dashes (- - -, - -) or plus sign (++++,++) are displayed. Use arrow buttons to scroll through all displayed parameters.	No <u>NaN</u> displayed.	Check if parameter is outside the measuring range. Check parameter display settings (number of digits).
Current parameter status of displayed readings	D-31x: Check logbook entries since last functional check. D-320: Parameter name is flashing in case of any error.	Red background for parameter indicates an error or alarm. Grey background indicates reading is not current.	See section 10 for Status- and Errorcodes. D-320: Use menu function <u>Monitore...</u> to check actual parameter status.

Check	Reason / possible error	Remark
Up-to-date: Readings actualised on regulary base?	- Measuring interval is too long - Automatic measurement has been stopped manually - Service mode activated	Consider measuring interval and smoothing.
Continuity: Check historical data (timeseries) for interruptions or discontinuities	- Change of monitored medium - Local calibration - Maintenance of sensor (cleaning, etc.) - Readings out of range - System failure (loss of power, communication error, etc.)	Only possible if timeseries are availbale.
Plausibility: Timeseries look plausible with daily or seasonal fluctuation	- Drift of readings (can be caused by aging of electrodes or fouling). - Increasing noise (can be caused by flow conditions or external interference). - Fixed readings / no fluctuation	Check logbook of plant operator if possible. Refer to section 10 for Troubleshooting.
Measuring range: Readings are within the specified and calibrated measuring range?		Quality of results might be reduced outside the specified range.
Accuracy: Difference between laboratory values and readings of the sensor	In case of significant difference a calibration has to be performed (please refer to section 6).	To verify the accuracy of the displayed readings, only a reliable and validated comparison method has to be used.

8.3 Check of Sensor Integrity

When there is any doubt regarding the integrity of the sensor, please use the following flowchart to check sensor and installation:

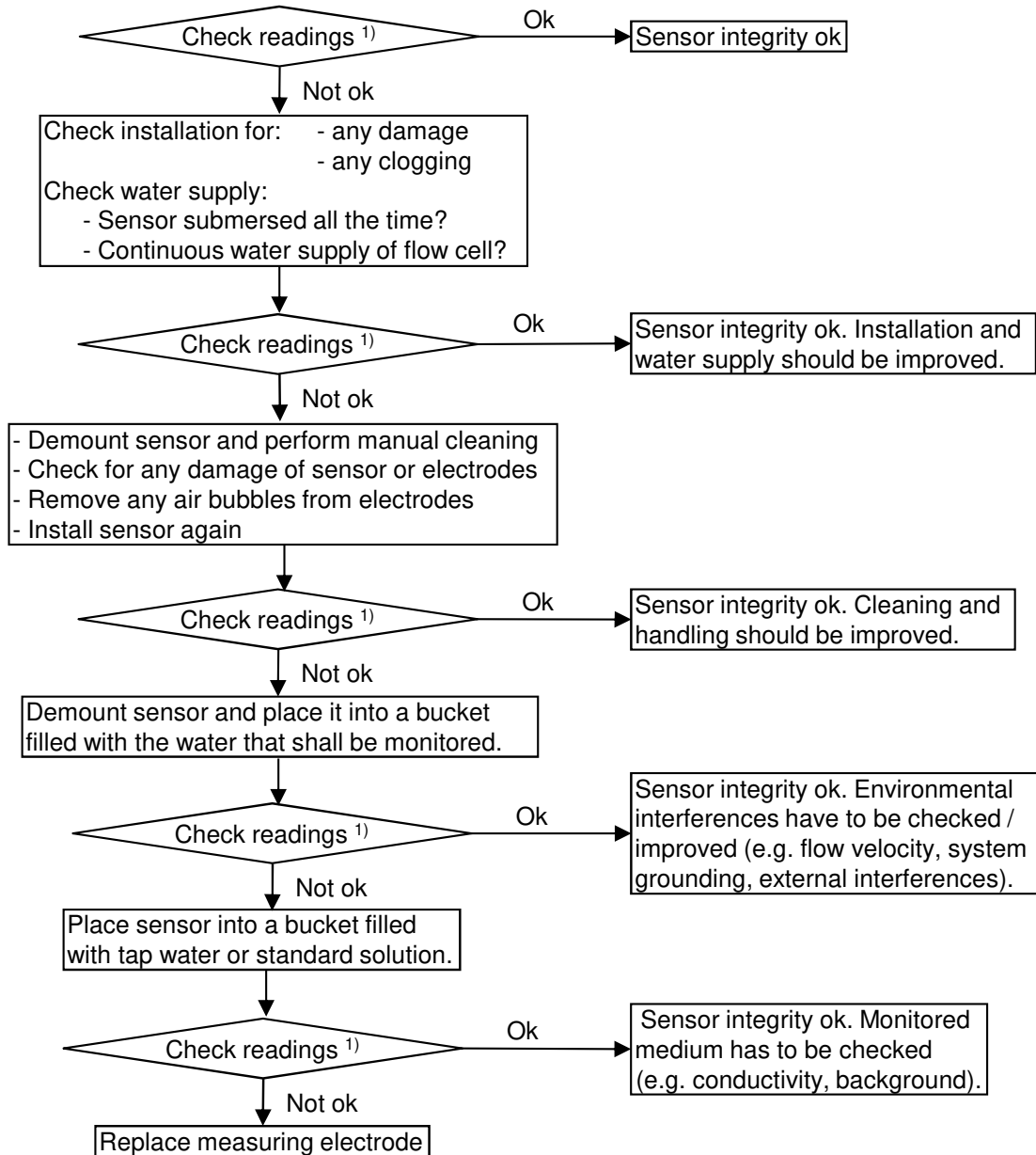

¹⁾ Check if the sensor readings are plausible and stable (no jumps, no scattering, no drift) for at least 5 consecutive measurements.

8.4 Check of Reading Accuracy

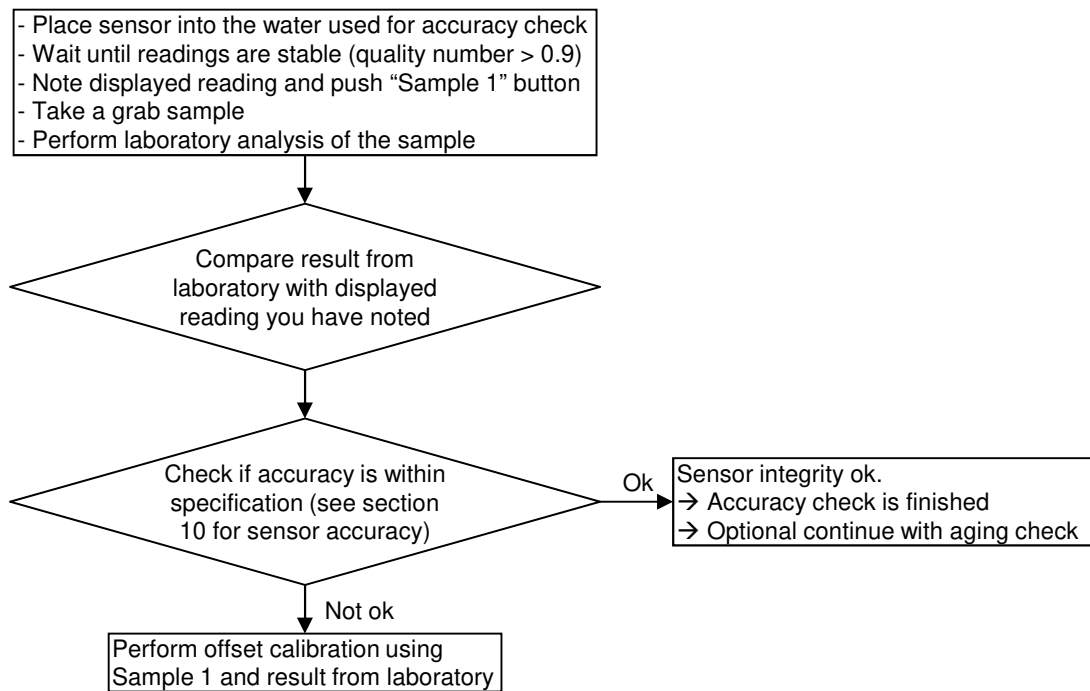

8.5 Check of Electrode Aging

Aging of an ISE electrode means the sensitivity decreases. This can be quantified by checking the electrode slope. The electrode slope of a new electrode is 56 mV per decade at 20°C (54 mV at 10°C and 58 mV at 30 °C). Once the electrode slope has reached the lower limit (i.e. 20% of original slope, see table below also), the electrode needs to be replaced.

Slope per decade	% of original slope	Electrode Status	Comment
25 - 59 mV	45 - 105 %	fully operational	electrode ok ¹⁾
12 - 25 mV	20 - 45 %	already aged	reduced accuracy, electrode can be replaced
< 12 mV	< 20 %	dead	electrode has to be replaced

¹⁾ The electrode slope of a new or refurbished electrode depends on the background matrix of the measured water. High amount of interfering ions and / or high conductivity will reduce the slope.

The actual electrode slope (i.e. the actual electrode status) can be checked by using one of the following possibilities:

- Performing a linear calibration. Whenever a linear calibration is performed, the electrode slope is checked internally. The linear calibration will be rejected in case the electrode slope is too low.
- When the console is used to perform the linear calibration, the electrode slope (slope per decade) will be displayed as additional information. Using the table above the operator can judge the actual electrode status.
- The electrode slope can be calculated by the operator himself based on the two sample readings in different standards with known concentrations (see formula for calculation below). If the difference of the used standards is a factor of 10 (e.g. 2 mg/l and 20 mg/l) the slope per decade is simply the difference of the mV readings.

$$\text{Slope per decade [mV]} = (\text{mV Sample1} - \text{mV Sample 2}) / (\text{LOG (mg/l Sample 1 / mg/l Sample 2)})$$

9 Maintenance

9.1 Cleaning

During routine operation the cleaning of the ammo::lyser / fluor::lyser, i.e. the measuring electrodes of the sensor, is performed automatically via compressed air. To clean the sensor manually the following is recommended:

 Before demounting the sensor be sure that automatic air cleaning is deactivated via operating software and air supply line is depressurised to avoid dirt and / or injury by suddenly escaping pressurized air.

- Rinse sensor with hand-hot (lukewarm) drinking water to remove coarse deposits from the sensor housing. To clean the sensor housing (not the electrodes themselves) a soft cleaning agent (e.g. dishwashing detergent) can be used.
- Put the sensor in a bucket of hand-hot drinking water for several minutes to remove deposits on and in between the measuring electrodes.
- The cleaning of the measuring electrodes is performed by using a soft cloth (one that does not leave behind fibres), cotton swabs or paper tissues that are moistened with tap water before they are applied.

When cleaning the measuring electrodes, care has to be taken that the membranes are not damaged (do not use abrasive materials such as scouring sponges or stiff brushes).

 Never use tenside or surfactant containing cleaning agents (washing liquid) to clean the electrodes or the membranes.

9.2 Refurbishment of Electrodes

The ISE electrode is a typical spare part and has to be replaced regularly. Some types of electrodes (NH4-N, K, NO3-N) can be refurbished at s::can. That means that all aged components (membrane cap, electrolyte) will be replaced and the refurbished electrode will be tested for it's quality by s::can.

This refurbishment can be ordered directly on the s::can homepage within the section Services using the ELRO-form.

The ELRO process is displayed below:

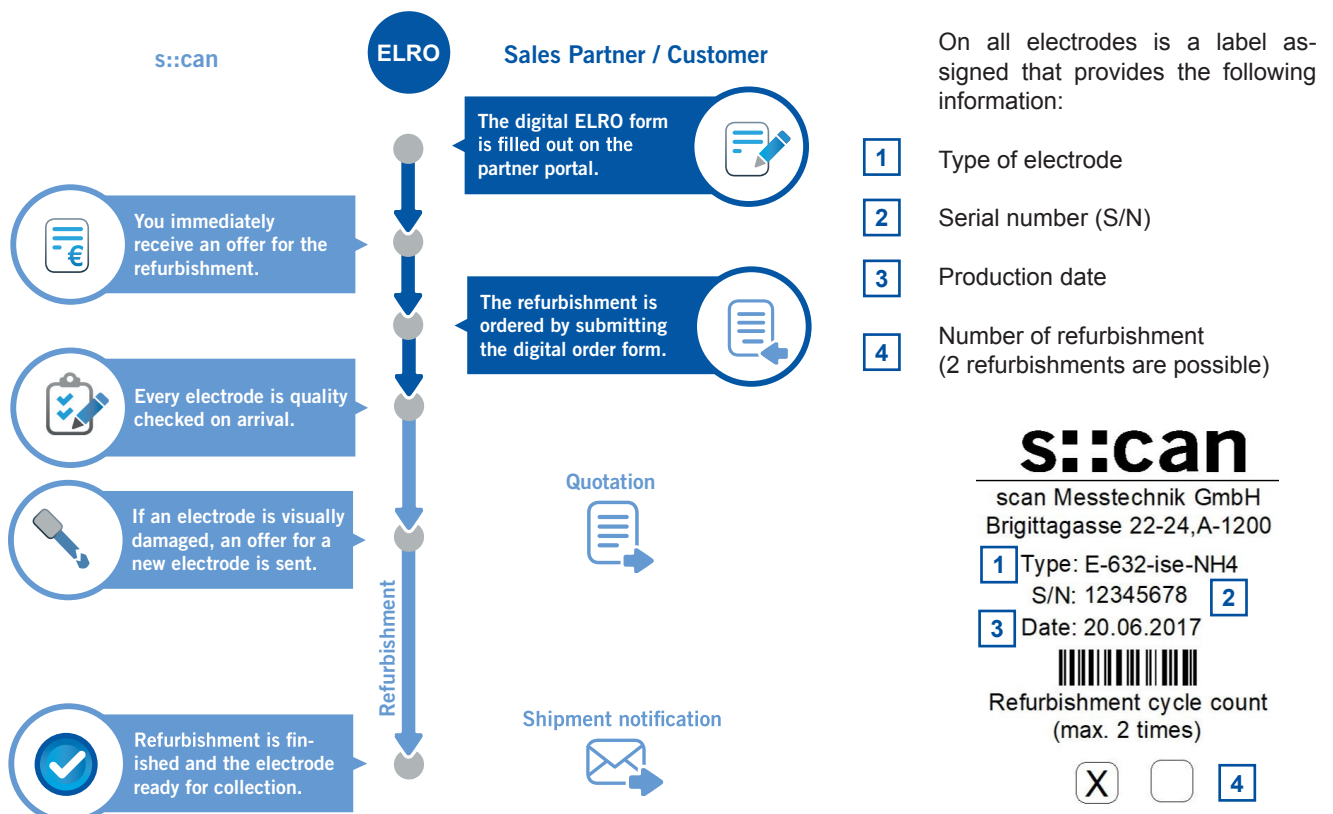

9.3 Replacement of Electrodes

The electrodes need to be replaced regularly (see technical specifications regarding life time). The replacement is performed by the following steps:

1 For replacement of the electrodes you need the ammo::lyser / fluor::lyser itself, replacement electrode, tool for electrode replacement (E-542-TOOL) and paper tissue for cleaning.



2 Clean the sensor as explained in section 9.1. Finally dry the electrodes and electrode head with an absorbant paper tissue.



3 Screw out the electrode that needs to be replaced using the tool for electrode replacement (E-542-TOOL). Doing this, hold the sensor slightly inclined to ensure no moisture can enter the electrode slot.



4 Remove the old electrode from the slot and check if there is any dirt or moisture within the electrode slot. Whipe it clean and dry with a paper tissue if needed.

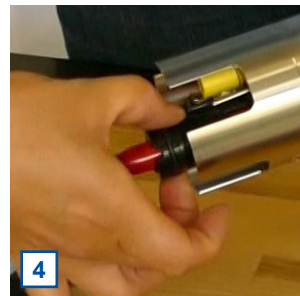

5 Unpack the new electrode carefully.



6 The pH- and reference electrodes are protected with a cap. Before removing the cap cut the cable strap that fixes the cap.



7 Take the new or refurbished ISE electrode and shake it like a mercury thermometer to remove air bubbles from the internal side of the membran.

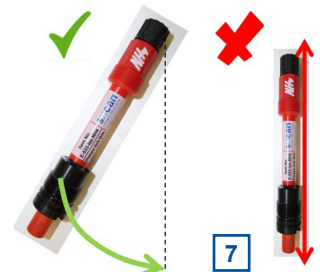

8 Make sure that the threads, all sealing O-rings and the electrode plug are clean and undamaged before putting the electrode carefully into the slot.



9 Putting a thin film of vasiline onto the O-ring makes it easier to screw in the electrode.



10 Carefully screw the electrode into the sensor using the electrode key (E-542-TOOL) until hand tight.



Finally install of the ammo::lyser / fluor::lyser according to the procedure described in section [5] and perform a local calibration of the new electrode according to the procedure described in section [6].

10 Troubleshooting

10.1 Typical Error Pattern

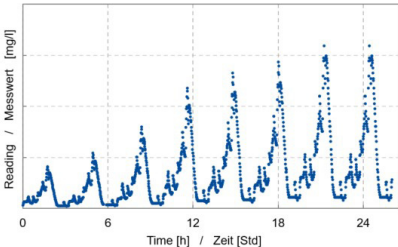
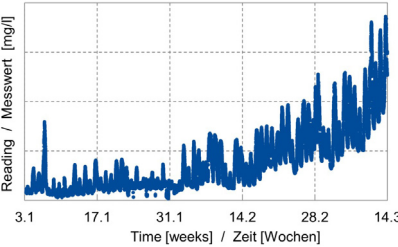
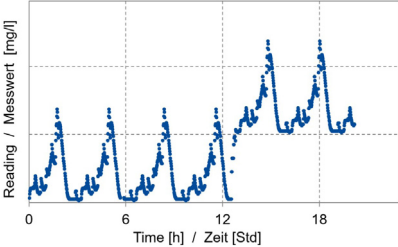
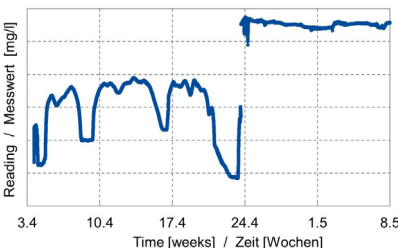
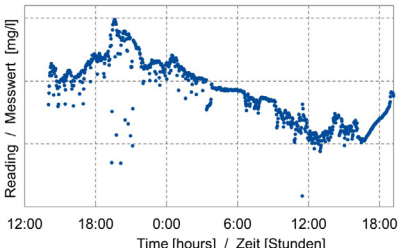
Error	Reason	Removal
<p>Drift of readings (after startup or electrode replacement)</p> 	<ul style="list-style-type: none"> ■ New electrodes need time to adapt to the measuring medium (conditioning time). 	<ul style="list-style-type: none"> ■ Conditioning of electrode before the installation. ■ Perform local calibration after the electrodes are completely conditioned.
<p>Drift of readings (during operation)</p> 	<ul style="list-style-type: none"> ■ Change in the measuring medium (e.g. interference of ions) ■ Air bubbles ■ ISE electrode aged ■ Electrode used for NH4-N compensation aged ■ Reference electrode aged 	<ul style="list-style-type: none"> ■ Check measuring medium ■ Remove air bubbles ■ Clean the sensor / electrodes ■ Perform linear calibration ■ Replace electrode
<p>Shift / jump of readings (offset) but still changes in concentration visible</p> 	<ul style="list-style-type: none"> ■ Small air bubbles sticking to the membrane ■ Dirt / deposition on the electrode ■ Sudden change in measuring medium composition 	<ul style="list-style-type: none"> ■ Remove air bubbles ■ Clean the sensor / electrodes ■ Check mV reading of sensor in tap water or standard ■ Perform check of accuracy (see section 8.4)
<p>Shift / jump of readings (offset) and no changes in concentration visible</p> 	<ul style="list-style-type: none"> ■ Large air bubbles sticking near the membrane surface ■ Fouling of the electrode caused by organics present in the measuring medium (chemical / mechanical damage) ■ Membrane mechanical damaged / destroyed 	<ul style="list-style-type: none"> ■ Remove air bubbles ■ Clean the sensor / electrode ■ Check mV reading of sensor in tap water ■ Perform linear calibration ■ Replace electrode
<p>Noisy readings (sudden periodical jumps) on single or all parameters</p> 	<ul style="list-style-type: none"> ■ Electromagnetic interference caused by other equipment installed nearby ■ Moisture or water ingress 	<ul style="list-style-type: none"> ■ Ensure that measuring medium is grounded correctly ■ Check if electrode slots are clean and dry ■ Check sensor integrity

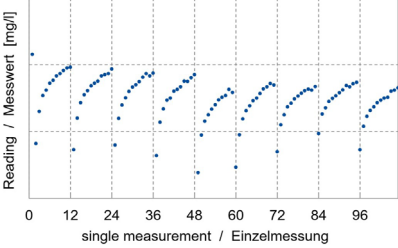
Error	Reason	Removal
Regular jumps of readings synchronized with automatic cleaning 	<ul style="list-style-type: none"> ■ Too intensive air pressure cleaning ■ Wrong automatic cleaning settings (waiting time between end of cleaning and measurement too short) 	<ul style="list-style-type: none"> ■ Reduce intensity / frequency of automatic cleaning. ■ Check if cleaning pressure is max. 4 bar. ■ Increase waiting time before measurement
Low accuracy of readings (readings too low or too high compared to laboratory values)		<ul style="list-style-type: none"> ■ Check sensor integrity ■ Check reading accuracy (see section 8.4)
One reading is NaN	<ul style="list-style-type: none"> ■ Reading out of measuring range ■ Parameter not calibrated correctly ■ Electrode defective 	<ul style="list-style-type: none"> ■ Check sensor integrity ■ Check reading accuracy (see section 8.4)
All displayed readings are NaN	<ul style="list-style-type: none"> ■ Communication problem between sensor and operation terminal ■ Sensor not installed correctly 	<ul style="list-style-type: none"> ■ Check connection plug and sensor cable ■ Reinstall sensor
Quality factor < 0.90 permanently	<ul style="list-style-type: none"> ■ Unstable measuring medium conditions (e.g. concentration, flow, temperature) ■ Damaged ISE or reference electrode 	<ul style="list-style-type: none"> ■ Check electrode readings in stable flow and temperature (use bucket filled with measuring medium if needed). ■ Visual inspection of electrodes for mechanical damage.

10.2 Error Messages and Status Messages

During execution of a measurement the monitoring system (system status), the measuring device itself (device status) and the result (parameter status) will be checked for possible errors and for plausibility. In case of an error (status bit will be set from 0 to 1) a user message will be displayed to the operator.

Depending on the used operation controller these messages will be shown on the display (Menu *Logbook & data* in case of con::lyte D-31x, function *Monitor...* in case of con::lyte D-320, *Status* tab in case of moni::tool and *Show Context Help* and *System-Status* in case of ana::pro) and also stored within the result files or logfiles. Additional to the user message (general error reason and recommendations for removal) the detailed status code will be displayed either in binary form (0000, 0001, 0010, 0011, 0100, etc.) or as a hex number (0x0001, 0x0002, 0x0004, 0x0008, 0x0010, etc.).



Up to 16 status bits are used for different errors. If several errors occur at the same time the con::lyte and moni::tool will add up all the status bits. This detailed information might be important if you request s::can support. Below you will find examples how to translate these combined hex codes:

Hex	Bin	Bits
0x8000	1000 0000 0000 0000	b15
0x8001	1000 0000 0000 0001	b0, b15
0x4011	0100 0000 0001 0001	b0, b4, b14

Within moni::tool the complete status code of a simple parameter has the following format: 0xTTTT.SSSS.PPPP.pppp.VVVV.vvvv.

Code	Status Type	Remark
0xTTTT	System status sensor	visible in the second column of all moni::tool parameter result files (e.g. Error 0x0010 or Ok 0x0002)
0xSSSS	Sensor status general	valid for all sensors
0xssss	Sensor status private	valid for respective sensor
0xPPPP	Parameter status general	valid for all parameters
0xpppp	Parameter status private	valid for respective parameter
0xVVVV	vali::tool status general	valid for all clean values of vali::tool software
0xvvvv	vali::tool status private	valid for respective clean values of vali::tool software

- 1 Within the moni::tool *Status* tab of the sensor you will see the system status sensor and the sensor status as clear text and as status code (0xTTTT.SSSS.ssss).
- 2 Within the moni::tool *Status* tab of the parameter you will see the parameter status and in case of activated vali::tool the vali::tool status also (0xPPPP.pppp.VVVV.vvvv).
- 3 Within the moni::tool results file of the sensor parameter the status (0xTTTT.SSSS.PPPP.pppp) will be stored in the column beside the measured value.
- 4 If vali::tool is active, the result file contains also the vali::tool status (0xVVVV.vvvv) in the column beside the cleaned value.

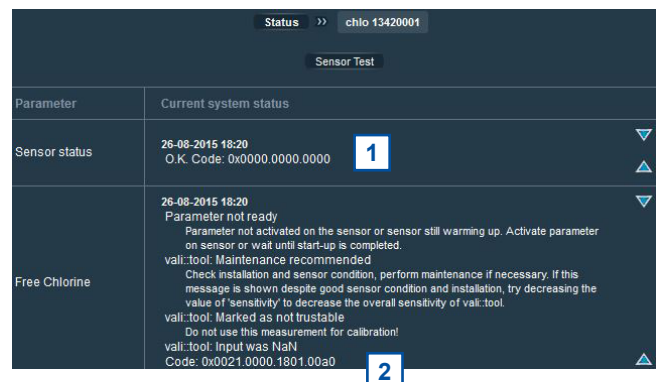

Timestamp	Station 1	ammo::lyser	ammo::lyser	ammo::lyser	ammo::lyser
Measurement interval	Status	NH4-N - Measured value [ppm]	Status [NH4-N - Measured value]	NH4-N - Clean value [ppm]	Status [NH4-N - Clean value]
31.05.2019 12:32	Ok 0x0000	4.25	Ok 0x0000.0000.0000.0000	3.33	Ok 0x0000.0000
31.05.2019 12:34	Ok 0x0000	4.78	Ok 0x0000.0000.0000.0000	3.43	Ok 0x0000.0000
31.05.2019 12:36	Ok 0x0000	6.05	Ok 0x0000.0000.0000.0000	3.61	Ok 0x0000.0000
31.05.2019 12:38	Ok 0x0000	58.24	Ok 0x0000.0000.0000.0000	3.84	Ok 0x1001.0010
31.05.2019 12:40	Ok 0x0000	123.67	Ok 0x0000.0000.0000.0000	8.64	Ok 0x0000.0000
31.05.2019 12:42	Ok 0x0000	139.51	Ok 0x0000.0000.0000.0000	18.57	Ok 0x0000.0000
31.05.2019 12:44	Ok 0x0000	136.43	Ok 0x0000.0000.0000.0000	28.85	Ok 0x0000.0000

The table below shows all errors regarding the operation terminal (system status) the user message, the reason of the error and notes for troubleshooting. If the error can't be removed although the suggested procedure was executed several times, please contact your s::can sales partner.

System Status Error 0xTTTT	Display con::lyte (D-31x / D-320)	Message moni::tool	Reason	Removal
0x0001 - b0	ES007 / COMM! Probe not detected. Check power-supply and connection cable.	No communication between sensor and terminal.	No communication between sensor and operation terminal. Replacement sensor was not installed correctly.	Check sensor cable and connector. Disconnect and reconnect sensor.
0x0002 - b1	0002	Invalid sensor	Sensor serial number has changed.	Connect the pre- viously installed sensor or perform sensor replacement (moni::tool) or new sensor installation (con::lyte).

The table below shows all errors regarding the used sensor incl. the user message, the reason of the error and notes for trouble shooting. If the error can't be removed although the suggested procedure was executed several times please contact your s::can sales partner.

Sensor Status Error 0xSSSS	Display con::lyte (D-31x / D-320)	Message moni::tool	Reason	Removal
0x0001 - b0	ES100 / 0001 Probe reports an error. Call service! Param.Status error. Status Code:	General sensor error	Sensor reports error during internal check. At least one internal sensor check failed.	For details see additional status message below. In case no further messages are shown, note the error code and contact your s::can sales partner.
0x0002 - b1	ES101 / 0002 MISUSE Medium temperature. Take probe out of medium, immediately!	SENSOR MISUSE	Operation outside the specification (e.g. temperature too high). This can damage the device permanently.	Take the sensor out of the medium immediately and check environmental conditions.
0x8000 - b15	ES115 / 8000 Device maintenance required Code 8000 0000	Sensor maintenance required	At least one internal sensor check reports a warning.	Perform function check of the sensor according the manual.

The table below shows all errors regarding the measured parameters incl. the user message, the reason of the error and notes for trouble shooting. If the error can't be removed although the suggested procedure was executed several times please contact your s::can sales partner.

Parameter Status Error 0xPPPP	Display con::lyte (D-31x / D-320)	Message moni::tool	Reason	Removal
0x0001 - b0	EP 100 / 0001 Status error. Code: 0001.0000 Details in following log messages.	General parameter error	At least one internal parameter check failed.	Note additional status message below. If no further message is displayed, note the error code and contact your local s::can sales partner.
0x0002 - b1	EP 100 / 0002 Parameter failure, hardware failure	Parameter error, Hardware error	Electrode signal not ok. An electrode is missing, too old or defective.	Check the electrode or replace the electrode.
0x0004 - b2		Parameter error, configuration error	Parameter error, configuration error	Change the local calibration or switch back to global calibration.
0x0008 - b3		Parameter error, Wrong medium	Sensor outside of the medium or in incorrect medium.	Check supply of medium and medium itself.
0x0010 - b4	EP 100 / 0010 Parameter failure, calibration failure	Parameter error, Incorrect calibration	Invalid sensor configuration. At least one calibration coefficient is invalid.	Check readings and lab values. Restart sensor by un- and replugging. Set back to factory settings. Repeat local calibration.
0x0020 - b5	EP 100 / 0020	Parameter not ready	Parameter not activated on the sensor or sensor still warming up.	Activate parameter or wait until sensor is fully operational.
0x8000 - b15	EP 115 / 8000 Out of range Code 8000 0000 The parameter is out of measurement range	Reading out of measuring range	Measured parameter is outside the defined measuring range.	Check if sensor is in the medium. Perform functional check.

The table below shows all errors regarding the measured parameters incl. the user message, the reason of the error and notes for trouble shooting. If the error can't be removed although the suggested procedure was executed several times please contact your s::can sales partner.

Parameter Status Error 0xpppp	Display con::lyte (D-31x / D-320)	Message moni::tool	Reason	Removal
0x0001 - b0	EP 100 / 0001 Electrode slope too low. Check calib or replace electrode. Reduced quality of measurement possible. P-Status(Pri): 0001	Calibration failed, incorrect offset and slope too low	Offset of local calibration out of limits and / or slope of electrode too low.	Check sample and laboratory values. Repeat local calibration. Replace Electrode if slope too low.
0x0002 - b1	EP 100 / 0002 Electrode slope too low. Check calib or replace electrode. Reduced quality of measurement possible. P-Status(Pri): 0002	Electrode slope out of limits	Slope of local calibration out of limits (too high or too low).	Check sample and laboratory values. Repeat local calibration. Replace Electrode if slope too low.

The table below shows all errors regarding clean parameters of the vali::tool software incl. the user message, the reason of the error and notes for trouble shooting. If the error can't be removed although the suggested procedure was executed several times please contact your s::can sales partner.

Parameter Status Error 0xVVVV	Message moni::tool	Reason	Removal
0x0001 - b0	vali::tool reports an error	At least one internal check reports a warning.	Check further status messages.
0x0800 - b11	Maintenance recommended	Parameter check reports a warning.	Check system and sensor, perform functional check.
0x1000 - b12	Marked as not trustable	Parameter check reports a warning.	Do not use this value for calibration.

10.3 Check of Device Settings

In case detailed sensor information or configuration settings have to be checked, the following sections will explain how to find these information when operating the sensor with a s::can controller.

10.3.1 Check of Device Settings using con::lyte D-31x

The main menu entry *Information* of the con::lyte operation software enables you to check internal sensor settings. After selecting the parameter of your interest by pushing the *Enter* button, the display will show the *upper limit* and the *lower limit* of the selected parameter.

When confirming the lowest entry *Probe* with *Enter* all internal settings of the sensor will be displayed. The most important ones are:

- Internal sensor identifier (*M-Version* and *Model*)
- Sensor name (*ammo::lyser*)
- Serialnumber of the sensor (*S/N*)
- Hardware version of the sensor (*H/W-Version*)
- Software version of the sensor (*S/W-Version*)

NH4-N [ppm]	
Upper limit:	19.8
Lower limit:	0.1
Offset:	0.93
Slope:	94.83
Probe	

10.3.2 Check of Device Settings using con::lyte D-320

Select the entry *Manage sensors...* in the main menu of the status screen. Select the name *ammo::lyser/0/1* in the list of installed sensors, in which the second number (*1*) indicates the address assigned to the sensor. After confirming the entry *Configure...* as well as the entry *Probesettings* in the next view, the following information of the sensor will be displayed:

- Internal sensor identifier (*M-Version* and *Model*)
- Sensor name (*ammo::lyser*)
- Serialnumber of the sensor (*S/N*)
- Hardware version of the sensor (*H/W-Version*)
- Software version of the sensor (*S/W-Version*)

Information of the single measuring parameter can be retrieved via the entry *Parameter info...* from the main menu of the parameter display. In addition to the parameter name (*Name*), the unit of measurement (*Unit*) the number of decimal places (*Disp. Format*), also the lower and upper limit of the parameter range (*P. lower* / *P. upper*) and the adjusted alarm range (*Al. lower* / *Al. upper*) are displayed.

P1/NH4-N	
Sen.:	ammo::lyser
Name:	NH4-N
Unit:	ppm
Disp. Format:	1
P. lower:	0,1
P. upper:	19,8
Al. lower:	----,---
Al. upper:	----,---

10.3.3 Check of Device Settings using moni::tool

Selecting *Service / ammo / Edit ammo* will list up internal settings of the ammo::lyser / fluor::lyser. Depending on the *Service Level* (figure below is *Service Level Advanced*) some or all of the following information will be displayed:

- Interface (COM-port, *Address*) of the sensor
- *Sensor name (Internal)* allocated to the device. Should not be changed by the operator.
- *Sensor name* for the display allocated to the device by the operator at installation.
- Manufacturer name of the sensor (*Vendor*)
- Type of the sensor (*Model*)
- Serial number of the sensor (*Serial Number*)
- Number of internal parameters of the sensor (*Parameter count*)
- Information regarding the purchase (*Purchase date, Warranty expiry date*). Can to be entered by the operator at initial startup.
- Actual hardware and software version of the sensor (*HW Version SW Version*).
- Internal type number of the sensor (*Sensor Model*) and information regarding cleaning and logging (not available for the ammo::lyser / fluor::lyser).
- Information regarding the installation and last modification of the sensor (date, name and reason).



10.4 Modification of Device Settings



Any modification of the device settings must be performed by trained service staff or after confirmation of your local s::can Sales Partner. In general the following device settings can be modified:

- Activation or deactivation of potassium compensation
- Modification of fixed values for parameter (with ana::pro only)
- Modification of device address (with ana::pro only)
- Modification of electrode type

10.4.1 Modification of Device Settings using moni::tool

Selecting *Service / ammo / Parameter / Edit Parameter* will list the parameter settings. The *Service Level Expert* has to be used to see all information as displayed below:

- *Potassium Compensation* is active when the checkbox is marked. A click on the checkbox will disable the compensation.
- The entry *Electrode type* defines, which ISE electrode is used in this slot. The following types are supported:
 - 0 Temperature
 - 2 pH
 - 4 Ammonium (NH4-N)
 - 5 Nitrate (NO3-N)
 - 6 Potassium (K)
 - 10 ... Chloride (Cl)
 - 11 ... Fluoride (F)
- The *Electrode unit* is selected in accordance to the parameter and can be changed to the raw signal (mV).
- The parameter output can be set permanently to a *Fix value*, which will be displayed and used instead of the real reading. This feature can be used, if an electrode, which is used for compensation, is defective until it is replaced.
- Any value that will be entered in the field *If NaN* will be displayed if the electrode will not delivery a reading.
- The entry *Cross correction parameter* defines the slot of the electrode that will be used for compensation of the actual selected parameter.
- The entry *Cross correction rate* defines the coefficient used for the compensation of cross sensitivity.

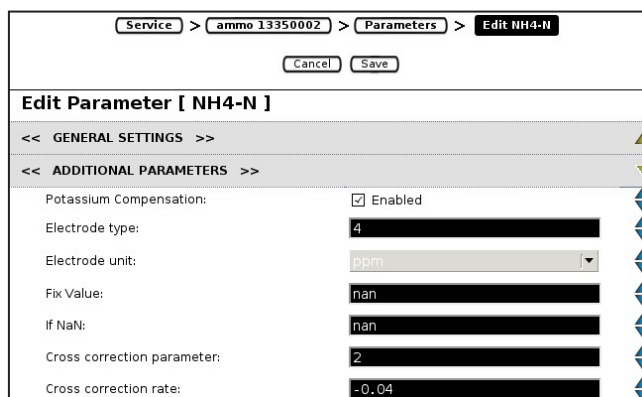

10.4.2 Modification of Device Settings using ana::pro

In the operating - and service software ana::pro the sensor can be initialised over the menu item *Parameter / Settings*. In case the parameter of interest is not yet displayed by default in the Parameter Settings window, they can be selected as explained below:

- Double click on the parameter field that you want to correspond with the parameter to be displayed.
- After double clicking, the window will enlarge and show detailed information belonging to this parameter.
- Select *Non-spectral parameter* in the upper selection bar.
- Select *ammo/chlori/ise::lyser* under *Device*.
- The *COM-Port* is the interface to which the sensor is connected (e.g. COM-Port of the con::nect).
- Enter the address allocated to the sensor in the RS 485 network in the entry *Address*.
- Push the button *Search...* (when an incorrect COM-Port and / or sensor address are selected, the *Search...* function will still find the sensor if only one instrument is connected).

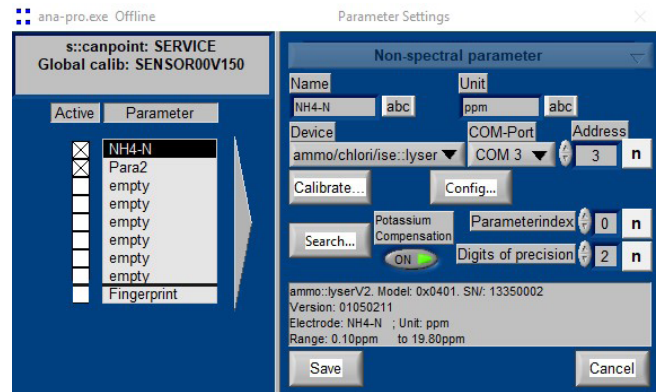

As soon as the sensor has been detected, information will be shown in the grey text field in the lower part of the dialogue window (model and serial number, version, electrodes and measuring range).

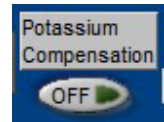

Furthermore information that *Potassium Compensation* is activated will be displayed by the green *ON* button. To deactivate the compensation simply push this button which will switch to *OFF*.

- Push button *Config...* in menu *Parameter / Settings*.
- Push button *Search...* in register card *Com*. As soon as the sensor will be detected, the checkbox (*status source*) in the lower right corner switches to ok (green check mark) and further register cards become visible.
- In register card *Device desc* the sensor type (*abModel*), the serial number of the sensor (*abSerialNumber*), the actual hardware (*abHWRelease*) and software (*abSWRelease*) are displayed.

In register card *Para config* the complete configuration of each measured parameter is displayed (see figure below).

- Within the entry *Parameterindex* the internal number of the electrode position can be entered. According to the figure in section 3.3 and the numbers on the electrode head index 0 = position 2, index 1 = position 3 and index 2 = position 4. To ensure you have the correct index, always check if the parameter name, which is displayed in field *abPiName* is correct.
- Besides the parameter name the actual used measuring range (*xxxLimitPi*) and the unit (*abPiUnit*) is displayed. Also actual used offset and slope (*fPiCalibCoeff*) and number of digits (*uiPiResolution*) are displayed.
- In the right part of the configuration screen the stored sample readings (mV) and laboratory values (ppm) are displayed. Only the first two samples can be used for local calibration. A new sample measurement can be triggered by pushing the *Take Sample* button. Furthermore both sample and laboratory values can be entered into the display field directly.

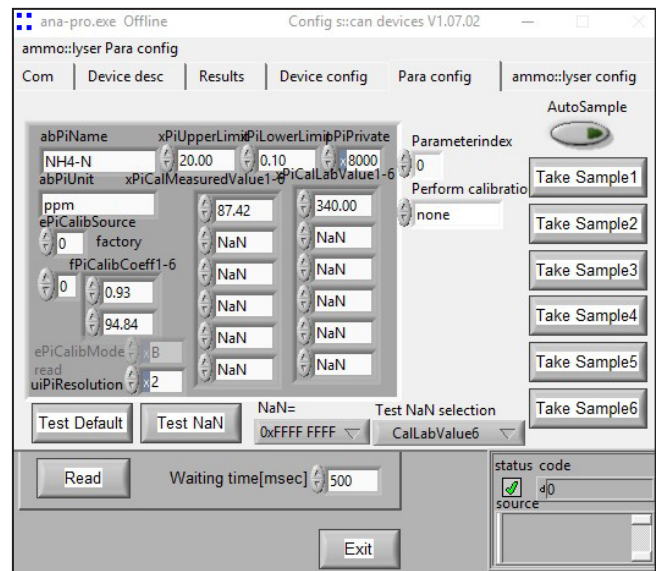

You can finish the configuration menu by pushing the button *Exit* or you can switch to the register card *ammo::lyser Para config*, which will display further configuration settings (see following figure).

- Within the field *ePiType* the electrode type used on this position is defined. Refer to section 10.4.1 to see which electrode types are supported. Besides the actual unit is displayed (2 = ppm and 3 = mV).
- Within the fields *fPiFixValue* and *fPiifNaN* the output can be set to a fixed value and also display of NaN readings can be changed (see section 10.4.1)
- In the right part of the configuration window the information needed to compensate and calculate the parameter readings are displayed.

All changes in any register card shall be done directly in the display field using the mouse and the keyboard. The scrollbar labelled with two small triangles beside the display field shall not be used.

After any change of the configuration, switch to register card *Device config* and select entry *save settings* in the selection field *eChangeSettings*. Then close configuration menu by pushing *Exit* and reboot ammo::lyser by powering off and on again. Finally check within the configuration menu if modifications have been stored correctly in the register card.

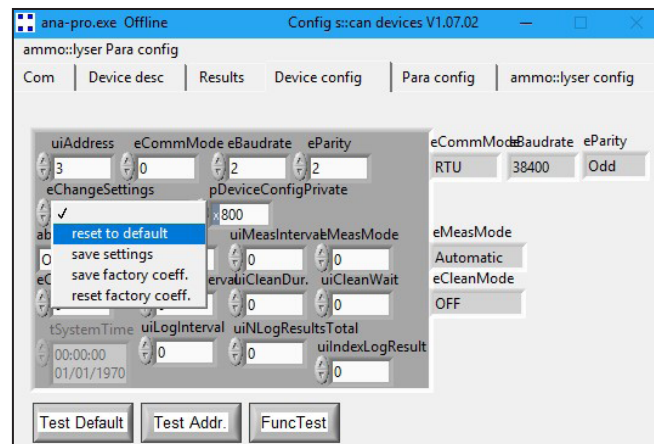
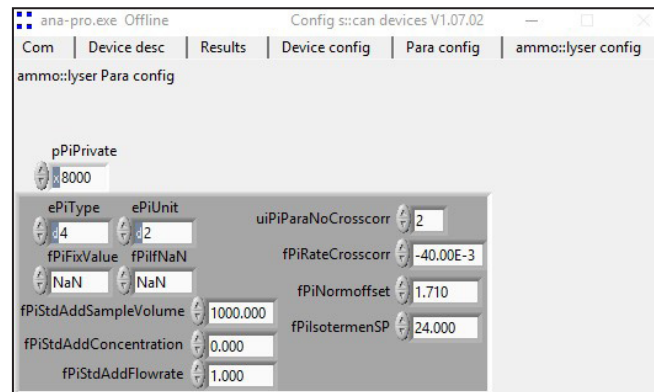

10.5 Return Consignment (RMA - Return Material Authorization)

Return consignments of the s::can monitoring system, or parts of the system, shall be done in a packaging that protects the device (original packaging or protective covering if possible). Before returning a consignment, you have to contact your s::can sales partner or s::can customer support (support@s-can.at). A RMA number will be assigned for each device, independent if the reason of the return consignment is service, repair or demo equipment.

RMA numbers can be requested from the s::can Customer Portal available on the s::can webpage directly. Return consignments without an RMA number will not be accepted. The customer always has to bear the costs for return consignment.

11 Accessories

11.1 Installation

11.1.1 Connection Cable

For operation of ammo::lyser / fluor::lyser with plug a connection cable is necessary. This is included in the standard order.

Name	Specification	Remark
Part-no.	C-1-010-SENSOR	
Cable lenght	1 m	
Assembling	ex works	
Dimensions plug	20 mm	outer diameter
Material	PU	Cable sheathing
Housing environment rating	IP 68	
Interface connection	IP 67, RS 485, 12 VDC	to s::can sensors



11.1.2 Extension Cable

The cable of the ammo::lyser / fluor::lyser can be elongated when necessary with an extension cable (10 m or 20 m length). The extension cable is attached using the sensor cable connector plug.

Name	Specification	Remark
Part-no.	C-210-SENSOR C-220-SENSOR	
Cable lenght	10 m 20 m	C-210-SENSOR C-220-SENSOR
Assembling	ex works	
Dimensions plug	20 mm	outer diameter
Material	PU	Cable sheathing
Housing environment rating	IP 68	
Interface connection	IP 67, RS 485, 12 VDC	to s::can sensors



11.1.3 Sensor Mounting

For proper and easy submersed installation of the ammo::lyser / fluor::lyser a separate sensor carrier is available. This part can be fixed to the sensor directly and can be extended by a pipe (to be provided by the customer).

Name	Specification	Remark
Part-no.	F-11-OXI-AMMO	
Material	PVC	
Dimensions	85 / 86 mm	Diameter / height
Weight	approx. 300 g	
Process connection	DN 50 inside	for extension pipe
Installation / mounting	submersed	



11.1.4 Flow Cell Setup Tap Water

For not submersed measurement of drinking / tap water sample stream in a bypass installation (e.g. monitoring station) with ammo::lyser / fluor::lyser, a separate flow cell is available.

Name	Specification	Remark
Part-no.	F-45-AMMO	
Housing material	POM-C	
Dimensions	90 / 113 mm	
Weight	xxx	
Process connection	1/4 inch inside	for inlet and outlet
Installation	flow-through	
Mounting	2 mounting holders	
Operating temperature	0 to 50 °C (32 to 122 °F)	
Operating pressure	0 to 6 bar (0 to 87 psi)	



11.1.5 Flow Cell Setup Waste Water

For not submersed measurement of a waste / raw water sample stream in a bypass installation (e.g. monitoring station) with ammo::lyser / fluor::lyser, a separate flow cell is available.

Name	Specification	Remark
Part-no.	F-48-AMMO	
Housing material	PVC	
Dimensions	177 / 108 / 83 mm	W / H / D
Weight	~ 0,5 kg	
Process connection	1 inch inside (G 1") 40 mm ID	via F-48-process direct connection to G 1"
Installation	flow-through (by-pass)	
Discharge	< 40 l/min	recommended
Operating temperature	0 to 50 °C (32 to 122 °F)	
Operating pressure	0 to 6 bar (0 to 87 psi)	

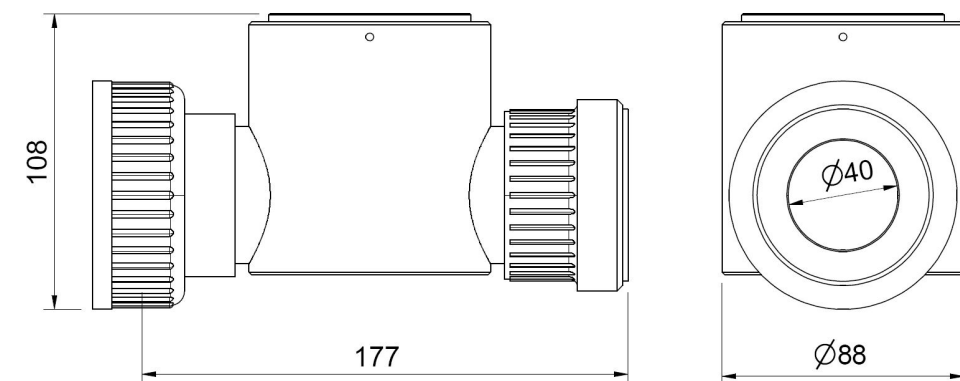
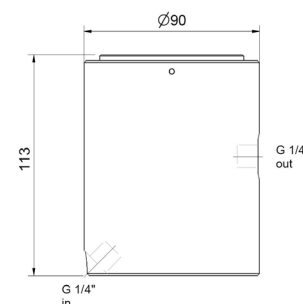

Dimension of flow cell setup in mm (F-48-AMMO)

11.1.6 System Panel micro::station / nano::station

For easy attachment of a complete s::can monitoring system (s::can operation terminal, flow cell setup, sensor) different types of mounting panels are available. The process connections of these panels can be ordered in DIN standard (EU) or in National Pipe Standard (US).

Name	Specification	Remark
Part-no.	F-501-ECO-xx F-506-PANEL-xx F-508-PANEL	Main panel micro::station Main panel nano::station Waste water panel
Material	PP PE	F-501, F-508 F-506
Dimensions W / H / D	450 / 750 / 10 mm 280 / 750 / 10 mm 375 / 690 / 10 mm (per part)	F-501-eco F-506-panel F-508-panel (2 parts)
Weight	~ 4.9 kg	

11.1.7 Pressure Connection Set

For connection of the ammo::lyser to the optional pressurized air cleaning system, a specific connection set is available.

Name	Specification	Remark
Part-no.	B-41	
Material	PU Nickel-plated-brass	tube connection fitting
Dimensions	3 m ID 4 mm / OD 6 mm	tube
Process connection	3/8 inch	connection fitting
Operating pressure	0 to 6 bar (0 to 87 psi)	



11.2 Spare Parts

11.2.1 Reference Electrode

The reference electrode needs to be replaced by a new one regularly. Please refer to the technical specification (section 12) regarding life time of electrode.

Name	Specification	Remark
Part-no.	E-532-ISE-REF E-533-ISE-REF	für Sensorversion V1 für Sensorversion V2
Scope of delivery	Electrode with protective cap	
Storage duration	max. 2 years	with protective cap
Storage temperature	2 to 40 °C (35 to 104 °F)	Storage in fridge recommended



11.2.2 pH Electrode

The pH electrode needs to be replaced by a new one regularly. Please refer to the technical specification (section 12) regarding life time of electrode.

Name	Specification	Remark
Part-no.	E-532-ISE-PH E-533-ISE-PH	für Sensorversion V1 für Sensorversion V2
Scope of delivery	Electrode with protective cap	
Storage duration	max. 2 years	with protective cap
Storage temperature	2 to 40 °C (35 to 104 °F)	Storage in fridge recommended



11.2.3 Ammonium Electrode (NH4-N)

The Ammonium electrode needs to be replaced either by a new or a refurbished one regularly. Please refer to the technical specification (section 12) regarding life time of electrode.

Name	Specification	Remark
Part-no. new electrode	E-532-ISE-NH4	for sensor version V1
	E-534-ISE-NH4	successor model for V1
	E-533-ISE-NH4	for sensor version V2
	E-535-ISE-NH4	successor model for V2
Part-no. refurbished electrode	E-632-ISE-NH4	for sensor version V1
	E-634-ISE-NH4	successor model for V1
	E-633-ISE-NH4	for sensor version V2
	E-635-ISE-NH4	successor model for V2
Storage duration	max. 1 year	see production date
Storage temperature	2 to 40 °C (35 to 104 °F)	Storage in fridge recommended



11.2.4 Potassium Electrode (K)

The Potassium electrode needs to be replaced either by a new or a refurbished one regularly. Please refer to the technical specification (section 12) regarding life time of electrode.

Name	Specification	Remark
Part-no. new electrode	E-532-ISE-K E-533-ISE-K	for sensor version V1 for sensor version V2
Part-no. refurbished electrode	E-632-ISE-K E-633-ISE-K	for sensor version V1 for sensor version V2
Storage duration	max. 1 year	see production date
Storage temperature	2 to 40 °C (35 to 104 °F)	Storage in fridge recommended



11.2.5 Nitrate Electrode (NO3-N)

The Nitrate electrode needs to be replaced either by a new or a refurbished one regularly. Please refer to the technical specification (section 12) regarding life time of electrode.

Name	Specification	Remark
Part-no. new electrode	E-532-ISE-NO3 E-533-ISE-NO3	for sensor version V1 for sensor version V2
Part-no. refurbished electrode	E-632-ISE-NO3 E-633-ISE-NO3	for sensor version V1 for sensor version V2
Storage duration	max. 1 year	see production date
Storage temperature	2 to 40 °C (35 to 104 °F)	Storage in fridge recommended



11.2.6 Chloride Electrode (Cl)

The Chloride electrode needs to be replaced by a new one regularly. Please refer to the technical specification (section 12) regarding life time of electrode.

Name	Specification	Remark
Part-no. new electrode	E-532-ISE-CL E-533-ISE-CL	for sensor version V1 for sensor version V2
Storage duration	max. 1 year	see production date
Storage temperature	2 to 40 °C (35 to 104 °F)	Storage in fridge recommended



11.2.7 Fluoride Electrode (F)

The Fluoride electrode needs to be replaced by a new one regularly. Please refer to the technical specification (section 12) regarding life time of electrode.

Name	Specification	Remark
Part-no. new electrode	E-532-ISE-F E-533-ISE-F	for sensor version V1 for sensor version V2
Storage duration	max. 1 year	see production date
Storage temperature	2 to 40 °C (35 to 104 °F)	Storage in fridge recommended



12 Technical Specifications

Name	Specification	Remark
Part-no.	E-532-PRO-nnn E-532-PRO-xxx-nnn E-532-ECO-nnn E-532-ECO-xxx-nnn E-542-nnn	PRO ... with Potassium compensation ECO ... without Potassium compensation xxx ... additional measuring parameter nnn ... plug (000) or cable (075)
Measuring parameter	Ammoniumnitrogen - NH ₄ -N Potassium - K Nitratennitrogen - NO ₃ -N Chloride - Cl Fluoride - F pH Temperature	on all E-532 on E-532-PRO only optional optional on E-542 optional on all versions
Measuring principle	Ion selective electrode (ISE)	
Compensation	Temperature pH Potassium	for all electrodes during calibration for NH ₄ -N measurement for NH ₄ -N measurement with pro version
Measuring range	NH ₄ -N: 0.1 - 1000 mg/l K: 1 - 1000 mg/l NO ₃ -N: 0.3 - 1000 mg/l Cl: 1 - 1000 mg/l F: 0.1 - 1000 mg/l pH: 2 - 12 pH Temp: 0 - 60 °C	readings displayed up to 1500 readings displayed up to 3900
Resolution	0.02 - 19.99: 0.01 mg/l 20.0 - 99.9: 0.10 mg/l 100 - 1000: 1.0 mg/l pH: 0.01 pH Temp: 0.1 °C	after linear calibration after linear calibration after linear calibration
Accuracy	ISE: < 5 % of measurement or +/- 0.2 mg/l pH: < 0.3 pH	the greater of the two values is valid
Response time	< 2 min	T ₉₀ between 10 ⁻³ and 10 ⁻² mol/l
Running in time (start up)	4 - 24 h	can be reduced by conditioning (e.g. in tap water)
Installation	submersed or in flow cell	
Environment rating	IP 67 (plug version -000) IP 68 (cable version -075)	due to connection plug on sensor
Operating temperature	0 to 45 °C (32 to 113 °F)	
Operating pressure	0 to 1 bar (0 to 14.5 psi)	
Operating flow	> 0.01 m/s < 3.00 m/s	Measurement in non flowing water (e.g. lakes) possible, max. value reduced in abrasive media.
Operating pH range	NH ₄ -N: < 8 (without pH compensation) NO ₃ -N: 2 - 12 K: 2 - 12 F: 5 - 8 (without pH compensation)	
Cross sensitivity NH ₄ -N	K: 1 : 25 Na: 1 : 100 Li: 1 : 2000	
Cross sensitivity NO ₃ -N	Cl: 1 : 200 Br: 1 : 1 I: 10 : 1	

Name	Specification	Remark
Cross sensitivity K	NH4-N: 1 : 200	
Cross sensitivity F	OH: 10 : 1	
Power supply	9 to 30 VDC	
Power consumption	0.72 W (typical)	
Dimension	60 / 350 mm 23.62 / 137.8 inch	Diameter / length (see section 3.3)
Weight	approx. 2.7 kg	
Housing material	POM-C, stainless steel 1.4571	Medium contacted
Interface connection	sys plug (IP 67), RS 485	to s::can operation controller, plug fits through 20 mm hole
Sensor cable length	7.5 m fixed cable (-075) or 1.0 m connection cable with plug connection on top of sensor (-000)	
Sensor cable specification	PUR (polyurethane jacket), 22 AWG, 6.3 mm (outside diameter); -30 to 80 °C (-22 to 176 °F)	older versions with grey sensor cable
Sensor cable assignment	Pin 1: Data - (green cable strand) Pin 2: Data + (pink cable strand) Pin 3: +12 VDC (red cable strand) Pin 4: Ground (black cable strand) Pin 5: not used Pin 6: Shielding (blank cable strand)	green (grey cable version) yellow (grey cable version) white (grey cable version) brown (grey cable version) black (grey cable version)
Storage temperature	Sensor incl. electrodes: 2 to 40 °C (35.6 to 104 °F)	for longterm storage of replacement electrodes 4 °C (39.2 °F) recommended.
Storage of sensor	dry, reference- and pH-electrode with protective cap filled with 3M potassium chloride solution	
Typical lifespan (application)	ISE electrode: 1/2 - 1 year pH-electrode: 1 year Reference electrode: 1 year	depending on application
Typical lifespan (storage)	ISE electrode: max. 1 year pH-electrode: max. 2 years Reference electrode: max. 2 years	at 4 °C (39.2 °F) with protective cap filled with KCl with protective cap filled with KCl
Refurbishment electrodes	for NH4-N, K, NO3-N only	max. 2 times per electrode possible
Automatic cleaning - sensor connection	G 1/8 inch for air hose OD 6 mm	
Automatic cleaning - specification	Pressure: 2 - 4 bar (29 - 58 psi) Duration: 2 - 6 Sek. Frequency: 10 min. - 6 hours	pressurized air free of oil and particles
Conformity - EMC	EN 50081-1, EN 50082-1 EN 60555-2, EN 60555-3	
Conformity - Security	EN 61010-1	



scan Messtechnik GmbH

Brigittagasse 22-24, 1200 Vienna, Austria
Tel.: +43 (0) 1 219 73 93 - 0
Fax: +43 (0) 1 219 73 93 - 12
office@s-can.at
www.s-can.at

