



O & M Manual



F12/D Toxic Gas Transmitter With H10 Smart Sensor

Home Office

Analytical Technology, Inc.
6 Iron Bridge Drive
Collegeville, PA 19426
Phone: 800-959-0299
610-917-0991
Fax: 610-917-0992
Email: sales@analyticaltechnology.com
www.AnalyticalTechnology.com

European Office

ATI (UK) Limited
Unit 1 & 2 Gatehead Business Park
Delph New Road, Delph
Saddleworth OL3 5DE
Phone: +44 (0)1457-873-318
Fax: + 44 (0)1457-874-468
Email: sales@atiuk.com

Table of Contents

SAFETY	IV	<i>Trouble Indication</i>	36
WARNINGS	IV	<i>Timed Return to Main Display</i>	36
HAZARDOUS LOCATION INSTALLATION	IV	<i>Inhibiting Alarms from the Main Display</i>	36
PART1 - INTRODUCTION	5	4.4 POP-UP DISPLAYS	36
1.1 GENERAL	5	<i>Sensor Removed Display</i>	36
1.2 H10 SMART SENSORS	6	<i>Sensor Installed</i>	36
1.3 SPECIFICATIONS.....	8	<i>Generator Removed</i>	37
PART 2 – MECHANICAL INSTALLATION	9	<i>Generator Installed</i>	37
2.1 TRANSMITTER MOUNTING	9	4.5 MAIN MENU	38
2.2 ENCLOSURE DIMENSIONS.....	9	<i>Main Menu</i>	38
2.3 WALL AND PIPE MOUNTING.....	10	<i>Alarm Active Menu</i>	38
2.4 PANEL MOUNTING (REMOTE SENSORS ONLY)..	12	4.6 SETUP MENU	38
2.5 DUCT SENSOR MOUNTING	12	4.7 SENSOR MENUS, METHODS, AND SETTINGS	39
2.6 DUCT MOUNT (INTEGRAL)	14	<i>Sensor Menu</i>	39
2.7 GENERATOR INSTALLATION/REMOVAL.....	14	<i>Sensor Settings Menu</i>	39
PART 3 – ELECTRICAL CONNECTIONS	15	<i>Sensor Model Menu</i>	39
3.1 TRANSMITTER CONNECTIONS.....	15	<i>Sensor Range Menu</i>	40
3.2 TERMINAL BOARD - SENSOR CONNECTIONS	16	<i>Sensor Calibration</i>	41
3.3 TERMINAL BOARD – LOOP POWER CONNECTIONS	17	<i>Sensor Calibration Menu</i>	42
3.4 HEATED SENSOR HOUSING WIRING	18	<i>Sensor Auto-test</i>	45
3.5 REMOTE SENSOR WIRING	19	4.8 ALARM MENUS, METHODS, AND SETTINGS	49
3.6 HEATED SENSOR WIRING (AC OR VDC POWERED)	20	<i>Alarms Menu</i>	49
3.7 HEATED REMOTE SENSOR WIRING (2-WIRE)...	21	<i>Gas Level Alarms</i>	49
3.8 DUCT MOUNT SENSOR WIRING	22	<i>Trouble Alarm</i>	53
3.9 SENSOR CONNECTIONS WITH 6 FT CABLE	22	<i>Alarm Inhibit</i>	57
3.10 AC OR 12-30 VDC POWERED	23	<i>Alarm Test Menu</i>	58
3.11 RELAY CONFIGURATION	24	4.9 DATA-LOG MENUS, METHODS, AND SETTINGS	59
3.12 REMOTE RESET INPUT	24	<i>Data Log Menu</i>	59
3.14 WIRING EXAMPLES	25	<i>Data Log Setup Menu</i>	60
3.15 AC OR 12-30 VDC POWERED	27	<i>Data Log View Menu</i>	60
3.16 HART POINT-TO-POINT (2-WIRE)	29	<i>Data Log Print Menus, Methods, and Settings</i>	62
3.17 COMMUNICATIONS JUMPER SETTING	30	4.10 I/O MENUS, METHODS AND SETTINGS	64
PART 4 - OPERATION	31	<i>I/O Menu</i>	64
4.1 OPERATOR INTERFACE PANEL.....	31	<i>4-20mA Output</i>	64
<i>Menus and Settings</i>	31	4.11 COM MENUS AND SETTINGS	66
<i>Moving the Cursor and Selecting</i>	31	<i>Relay Operation, Menus, and Settings</i>	70
<i>Editing Settings</i>	31	4.11 PANEL MENUS, METHODS, AND SETTINGS	72
4.2 STARTUP	32	<i>Panel Menu</i>	72
<i>Transmitter Review</i>	32	<i>Display Menu</i>	72
<i>Sensor Review</i>	33	<i>Security Menu</i>	73
<i>Generator Review</i>	34	4.12 SYSTEM MENU	77
4.3 MAIN DISPLAY	35	<i>Clock Menu</i>	77
<i>Main Reading</i>	35	<i>Reset Menu</i>	77
		<i>Version Menu</i>	78
		PART 5 – MAINTENANCE	79
		PART 6 – SPARE PARTS	81

Table of Figures

FIGURE 1- TRANSMITTER W/SENSOR & GENERATOR.....	5	FIGURE 44. SENSOR MENU.....	39
FIGURE 2. ENCLOSURE DIMENSIONS, (RS485 NO RELAYS).....	9	FIGURE 45. SENSOR SETTINGS MENU.....	39
FIGURE 3 DEEP ENCLOSURE DIMENSIONS	10	FIGURE 46. SENSOR MODEL MENU.....	39
FIGURE 4 WALL/PIPE MOUNTING BRACKET.....	10	FIGURE 47. SENSOR RANGE MENU.....	40
FIGURE 5. WALL MOUNTING DIAGRAM	11	FIGURE 48. DATA-LOG WARNING MESSAGE.....	40
FIGURE 6. PIPE MOUNTING DIAGRAM.....	11	FIGURE 49. SENSOR CALIBRATION MENU.....	42
FIGURE 7. PANEL MOUNTING DETAILS [DEEP CASE].....	12	FIGURE 50. SENSOR ZERO CAL. SETUP.....	42
FIGURE 8 DUCT MOUNT SENSOR EXPLODED VIEW.....	13	FIGURE 51. SENSOR ZERO CAL.MENUS.....	42
FIGURE 9. DUCT-MOUNT ASSEMBLY.....	13	FIGURE 52. SENSOR SPAN CAL. SETUP.....	43
FIGURE 10 - DUCT MOUNT (INTEGRAL) TRANSMITTER DIMENSIONS.....	14	FIGURE 53. SENSOR SPAN CAL. MENUS.....	43
FIGURE 11 - GENERATOR EXPLODED VIEW	14	FIGURE 54. SENSOR CALIBRATION HISTORY MENUS..	44
FIGURE 12. F12/D TRANSMITTER CONFIGURATIONS..	15	FIGURE 55. AUTO-TEST MENU	45
FIGURE 13. SENSOR/GENERATOR TERMINAL WIRING.	16	FIGURE 56. AUTO-TEST SETUP MENU.....	46
FIGURE 14. POWER AND COMMUNICATION TERMINALS.	17	FIGURE 57. AUTO-TEST SETUP OPTIONS MENU.....	46
FIGURE 15 - HEATED SENSOR WIRING DIAGRAM	18	FIGURE 58. AUTO-TEST NEXT AT MENU	46
FIGURE 16 - REMOTE SENSOR WIRING.....	19	FIGURE 59. AUTO-TEST HISTORY MENU	47
FIGURE 17 - REMOTE SENSOR WIRING.....	20	FIGURE 60. GAS GENERATOR DISPLAY.....	47
FIGURE 18 - HEATED REMOTE SENSOR WIRING	21	FIGURE 61. AUTO-TEST STATUS DISPLAY	47
FIGURE 19 - DUCT MOUNT SENSOR WIRING.....	22	FIGURE 62. AUTO-TEST STATUS DISPLAY SEQUENCE.	48
FIGURE 20 - WIRING CONNECTIONS - 6 FT SENSOR CABLE.....	22	FIGURE 63. ALARMS MENU.....	49
FIGURE 21 - POWERED ALARM RELAY CONTACTS.....	23	FIGURE 64. TOXIC GAS ALARMS.	49
FIGURE 22 - RELAY CONFIGURATION JUMPER LOCATION	24	FIGURE 65. OXYGEN DEFICIENCY ALARMS.....	49
FIGURE 23 - REMOTE RESET INPUT	24	FIGURE 66. HIGH ALARM OPERATION	50
FIGURE 24 - ATI A17/B14 RECEIVER MODULES.....	25	FIGURE 67. LOW ALARM OPERATION.....	50
FIGURE 25 - RA485 MULTIDROP W/4-20MA SIGNALING	26	FIGURE 68. ALARM INDICATOR FLAGS.....	51
FIGURE 26 - RS485 MULTIDROP W/O 4-20MA SIGNALING.....	26	FIGURE 69. ALARM STATUS MENU	51
FIGURE 27 - AC OR 12-30 VDC POWERED RELAY BOARD WIRING.....	27	FIGURE 70. ALARM RESET MENU.....	51
FIGURE 28 - COMMUNICATION W/4-20 LOOP OUTPUT	28	FIGURE 71. ALARM SETTING MENUS	52
FIGURE 29 - HART POINT-TO-POINT (2-WIRE)	29	FIGURE 72. TROUBLE INDICATION ON MAIN DISPLAY ..	53
FIGURE 30. COMM. INTERFACE JUMPER.....	30	FIGURE 73. TROUBLE STATUS DISPLAY	53
FIGURE 31. OPERATOR INTERFACE PANEL.....	31	FIGURE 74. ALARM INHIBIT MENU.....	57
FIGURE 32. EXAMPLE EDIT	32	FIGURE 75. ALARM TEST MENU	58
FIGURE 33. TRANSMITTER REVIEW DISPLAYS	32	FIGURE 76. DATA LOG MENU.....	59
FIGURE 34. SENSOR REVIEW DISPLAY.....	33	FIGURE 77. DATA LOG SETUP MENU	60
FIGURE 35 - GENERATOR NORMAL REVIEW.....	34	FIGURE 78. DATA LOG VIEW MENU	60
FIGURE 36 - GENERATOR TROUBLE REVIEW	34	FIGURE 79. DATA LOG GRAPH VIEW.....	61
FIGURE 37. MAIN DISPLAY.....	35	FIGURE 80. DATA LOG GRAPH VIEW MENU.....	61
FIGURE 38. MAIN DISPLAY TROUBLE INDICATION	36	FIGURE 81. DATA LOG SINGLE VIEW MENU.....	62
FIGURE 39. SENSOR REMOVED DISPLAY.....	36	FIGURE 82. DATA LOG PRINT EXAMPLE	62
FIGURE 40. GENERATOR REMOVED DISPLAY.....	37	FIGURE 83. DATA LOG PRINT MENU.....	63
FIGURE 41. MAIN MENU	38	FIGURE 84. DATA LOG PRINT FORMAT MENU	63
FIGURE 42. ALARM ACTIVE MENU.....	38	FIGURE 85. I/O MENU.....	64
FIGURE 43. SETUP MENU.	38	FIGURE 86. GRAPH OF 4-20MA OUTPUT.....	64
		FIGURE 87. 4-20MA MENU.....	65
		FIGURE 88. 4-20MA CONTROL PAGE.....	65
		FIGURE 89. ADJUST 4MA MENU	65
		FIGURE 90. ADJUST 20MA MENU.....	66
		FIGURE 91. COM MENU	66
		FIGURE 92. COM SETUP MENU.....	67
		FIGURE 93. HART MENU.....	68

FIGURE 94. HART IDENTIFICATION MENU.....	68
FIGURE 95. HART FIND-DEVICE DISPLAY.....	69
FIGURE 96. MODBUS MENU	69
FIGURE 97 ALARM RELAY DIAGRAM	71
FIGURE 98. RELAYS MENU	71
FIGURE 99. RELAY SETUP MENU.....	72
FIGURE 100. PANEL MENU	72
FIGURE 101. DISPLAY MENU.....	73
FIGURE 102. SECURITY MENU	73
FIGURE 103. ACTIVATING SECURITY	74
FIGURE 104. DEACTIVATING SECURITY.....	75
FIGURE 105. CHANGING THE SECURITY CODE.....	76
FIGURE 106. SYSTEM MENU	77
FIGURE 107. CLOCK MENU.....	77
FIGURE 108. RESET MENU	77
FIGURE 109. VERSION MENU.....	78
FIGURE 110 - EXPLODED VIEW	81

SAFETY

Read and understand this manual before installing, operating, or maintaining the F12/D Transmitter. Pay particular attention to the warnings and cautions below. All of the warnings and cautions shown here are repeated in the appropriate sections of the manual.

Protection from hazards may be impaired if used in manners not specified in this manual.

Warnings

- Installation must be in accordance with the recognized standards of the appropriate authority in the country concerned.
- Servicing of this unit must be performed by trained personnel.
- Before servicing, ensure local regulations and site procedures are followed.
- To prevent ignition of flammable or combustible atmospheres, disconnect power before servicing.
- The transmitter must be earthed/grounded for electrical safety and to limit the effects of radio frequency interference. An Earth ground point is provided inside the unit. To maintain EMI ratings, use shielded cable, connecting the shield/drain to the EARTH terminal in the unit, and the shield/drain to an Earth Ground at the power supply.
- Operate only in the specified temperature range.
- Verify transmitter after installation, after service events, and periodically to ensure the safety and integrity of the system.
- Electrostatic discharge hazard.
 - Take the necessary antistatic precautions if you: handle, install or use the device in potentially explosive atmospheres.
 - Do not install in a location (i.e.: near to ventilation systems) where the electrostatic charge can increase.
 - Do not clean plastic parts in a hazardous area.
- Use only Panasonic CR2032 batteries

Hazardous Location Installation

- The F12/D is not rated for hazardous locations

Part1 - Introduction

1.1 General

F12/D Gas Transmitter

The F12/D Gas Transmitter is used to monitor for gas leaks near storage cylinders, process piping, or gas feed equipment in nearly any type of industrial plant environment. It is housed in NEMA 4X, polycarbonate enclosure and features an H10 Smart Sensor, a non-intrusive four button user interface with a backlit transfective graphics display, three level alarms with three (optional) alarm relays, a high-resolution 4-20mA current loop output, real-time clock, data-logger, and optional HART™ or Modbus™ communication interface. In addition, the transmitter offers several optional E18 gas generators for automatic, timed testing of H10 sensors.

H10 Smart Sensor and E18 Gas Generator

H10 Smart Sensors and E18 generators contain non-volatile memory to store information about the target gas they were designed to monitor, or generate. They contain general information about the target gas, such as the name, range, units, alarm settings, along with specific calibration information, such as response to gas, mA-Hr of usage, and calibration history. Information is transferred into the transmitter at startup, and whenever one of the components is inserted into a live transmitter. Because all calibration data is stored in the memory, sensor modules may be calibrated using a spare transmitter in the shop, and subsequently installed into a field transmitter, eliminating the need for field calibration.

Sensors are inserted into the housing at the base of the transmitter. They are easily removed, and installation is simplified by way of an indexing groove that aligns the connector for a perfect fit. Once installed, a threaded port cap secures it in place.



Figure 1- Transmitter w/Sensor & Generator

Sensors are designed for use in ambient air at temperatures of -30 °C to +60 °C, at a relative humidity between 20 and 98 %RH (some sensors are rated to -40 °C, oxygen sensors are rated to -10 °C). Operating sensors in extremely dry air, or in condensing gas streams, is not recommended.

Generators are inserted into the optional generator housing attached to the bottom of the sensor housing at the base of the transmitter. Installation of a generator is simplified by way of an indexing groove that aligns the connector for a perfect fit. Once installed apply a little pressure to the top of the generator, and tighten the set screw (using the ATI screwdriver) on the housing to provide a secure fit. An O-Ring in the sensor cap provides the mechanism for securing the generator to the transmitter. Simply press the generator into the bottom of the sensor cap until it is secure.

1.2 H10 Smart Sensors

Gas	Part No.	Standard Range	Minimum Rang	Maximum Range
GENERAL GASES				
Acetylene	00-1057	0-200 PPM	0-50 PPM	0-500 PPM
Alcohol	00-1043	0-200 PPM	0-50 PPM	0-500 PPM
Alcohol	00-1044	0-500 PPM	0-500 PPM	0-2000 PPM
Ammonia	00-1010*	0-100 PPM	0-50 PPM	0-500 PPM
Ammonia	00-1011	0-1000 PPM	0-500 PPM	0-2000 PPM
Carbon Monoxide	00-1012*	0-100 PPM	0-50 PPM	0-1000 PPM
Dimethylamine (DMA)	00-1450	0-100 PPM	0-100 PPM	0-200 PPM
Ethylene Oxide	00-1039*	0-20 PPM	0-20 PPM	0-200 PPM
Formaldehyde	00-1040*	0-20 PPM	0-20 PPM	0-200 PPM
Formaldehyde	00-1349	0-1000 PPM	0-500 PPM	0-2000 PPM
Hydrogen	00-1041	0-2000	0-500 PPM	0-2000 PPM
Hydrogen	00-1013	0-4 %	0-1%	0-10 %
Nitric Oxide	00-1021	0-100 PPM	0-50 PPM	0-500 PPM
NOx	00-1181	0-200 PPM	0-50 PPM	0-500 PPM
Oxygen	00-1014	0-25%	0-10%	0-25%
Phosgene	00-1015	0-1 PPM	0-1 PPM	0-5 PPM
Phosgene	00-1016	0-100 PPM	0-5 PPM	0-100 PPM
OXIDANT GASES				
Bromine	00-1000*	0-1 PPM	0-1 PPM	0-5 PPM
Bromine	00-1001*	0-10 PPM	0-5 PPM	0-200 PPM
Chlorine	00-1002*	0-1 PPM	0-1 PPM	0-5 PPM
Chlorine	00-1003*	0-10 PPM	0-5 PPM	0-200 PPM
Chlorine Dioxide	00-1004*	0-1 PPM	0-1 PPM	0-5 PPM
Chlorine Dioxide	00-1005*	0-10 PPM	0-5 PPM	0-200 PPM
Chlorine Dioxide	00-1359	0-1000 PPM	0-200 PPM	0-1000 PPM
Chlorine Dioxide	00-1425	0-1 PPM	0-1 PPM	0-5 PPM
Fluorine	00-1006*	0-1 PPM	0-1 PPM	0-5 PPM
Fluorine	00-1007*	0-10 PPM	0-5 PPM	0-200 PPM
Hydrogen Peroxide	00-1042*	0-10 PPM	0-10 PPM	0-200 PPM
Hydrogen Peroxide	00-1169	0-1000 PPM	0-200 PPM	0-2000 PPM
Iodine	00-1036*	0-1 PPM	0-1 PPM	0-5 PPM
Iodine	00-1037*	0-10 PPM	0-5 PPM	0-200 PPM
Ozone	00-1008*	0-1 PPM	0-1 PPM	0-5 PPM
Ozone	00-1009*	0-10 PPM	0-5 PPM	0-200 PPM
Ozone	00-1358	0-1000 PPM	0-200 PPM	0-1000 PPM

(continued on next page)

<u>ACID GASES</u>				
Hydrogen Bromide	00-1455*	0-20 PPM	0-10 PPM	0-200 PPM
Hydrogen Chloride	00-1017*	0-10 PPM	0-10 PPM	0-200 PPM
Hydrogen Cyanide	00-1018*	0-10 PPM	0-10 PPM	0-200 PPM
Hydrogen Fluoride	00-1019*	0-10 PPM	0-10 PPM	0-200 PPM
Hydrogen Sulfide	00-1020*	0-50 PPM	0-10 PPM	0-500 PPM
Hydrogen Sulfide	00-1469	0-500 PPM	0-200 PPM	0-1000 PPM
Nitrogen Dioxide	00-1022*	0-10 PPM	0-10 PPM	0-200 PPM
Sulfur Dioxide	00-1023*	0-10 PPM	0-10 PPM	0-200 PPM
General Acid Gases	00-1038*	0-10 PPM	0-10 PPM	0-200 PPM
<u>HYDRIDE GASES</u>				
Arsine	00-1024	0-1000 PPB	0-500 PPB	0-2000 PPB
Arsine	00-1025	0-10 PPM	0-10 PPM	0-200 PPM
Diborane	00-1026	0-1000 PPB	0-500 PPB	0-2000 PPB
Diborane	00-1027	0-10 PPM	0-10 PPM	0-200 PPM
Germane	00-1028	0-1000 PPB	0-500 PPB	0-2000 PPB
Germane	00-1029	0-10 PPM	0-10 PPM	0-200 PPM
Hydrogen Selenide	00-1030	0-1000 PPB	0-500 PPB	0-2000 PPB
Hydrogen Selenide	00-1031	0-10 PPM	0-10 PPM	0-200 PPM
Phosphine	00-1032	0-1000 PPB	0-500 PPB	0-2000 PPB
Phosphine	00-1033	0-10 PPM	0-10 PPM	0-200 PPM
Phosphine	00-1034	0-1000 PPM	0-200 PPM	0-2000 PPM
Silane	00-1035	0-10 PPM	0-10 PPM	0-200 PPM
Silane	00-1285	0-1000 PPB	0-500 PPB	0-2000 PPB

*Corresponding E18 gas generator available for standard range of sensor, and lower.

1.3 Specifications

Sensor Type	Electrochemical cell
Gas Type	Sensor dependent (refer to list of available sensor types)
Range	User adjustable within limits of selected sensor (refer to list of available sensor types)
Response Time	Sensor dependent
Accuracy	Generally, $\pm 10\%$ of value, but limited by available calibration gas accuracy.
Repeatability	$\pm 1\%$ (Electronic)
Linearity	$\pm 0.5\%$ (Electronic)
Zero Drift	Less than 2% full scale per month
Span Drift	Dependent on operating environment but generally less than 3% per month
Analog Output	4-20 mA, 700 ohms max. at 24 VDC, 100 ohms max. at 12 VDC.
Serial Interface Options	HART® FSK (digital signaling on 4-20mA loop) MODBUS over RS232/485
Alarm Relay Board Option	Provides power to transmitter, relays, LCD backlight, RS232/485 port; Requires Deep Case Three SPST relays (two with N/O contacts, one with N/C contacts) Each relay: 5A @ 230 VAC resistive; 5A @ 30 VDC resistive Coils are programmable as normally energized or normally de-energized
Transmitter Power Requirements	Standard or optional HART™ FSK, 2-wire loop: 25mA@12-30 VDC, max. Optional Modbus RS485: additional 50mA@24VDC to AUX terminals nom. Auxiliary power for Heated Sensor Housing option, 24 VDC, 93 mA max
Relay Board Power Requirements	AC Alarm Relay Board, 115/230 VAC, 4.4W max. (see above) DC Alarm Relay Board, 12-30VDC, 3.1W max. (see above)
Enclosure	IP 65, polycarbonate with stainless steel hardware. Weatherproof and corrosion resistant (Standard H x W x D): 4.9" x 4.9" x 5.5" (124mm x 124mm x 139mm) Refer to Mechanical Installation section for dimensions of models with options
Mounting	(Standard) Wall or pipe mount bracket. U-Bolts suitable for 1.5" or 2" I.D. (Optional) Panel mount kit available.
Auto-Test Option	Dependent on sensor gas type and full-scale range
Display	Graphics LCD, 96w x 32h, backlighted*, transfective *Backlight disabled in 2-wire loop power mode
Controls	Four, dome-type push buttons; Remote alarm reset input (w/optional alarm relays only)
Operating Environm	-30 °C to +60 °C (Min. temp. for O ₂ sensor is -10 °C) 10 to 95% RH (non-condensing) IP 65
Weight	1.5 lb. (0.68 kg)

Part 2 – Mechanical Installation

2.1 Transmitter Mounting

Threaded inserts in the rear of the enclosure permit the attachment of brackets for securing the transmitter to a wall or pipe. An optional bracket is also available for “flush mounting” the transmitter into a panel, so that only the front cover protrudes. (This option is available for Remote AC powered units **ONLY**.)

Choose a location so the transmitter display is readily visible, and the panel buttons and sensor are accessible for calibrations. Consider the remote sensor option to locate the sensor closer to the source of a potential gas leak, or closer to the floor for gasses heavier than air.

2.2 Enclosure Dimensions

Dimensions and the conduit entry locations are detailed in Figure 2 below.

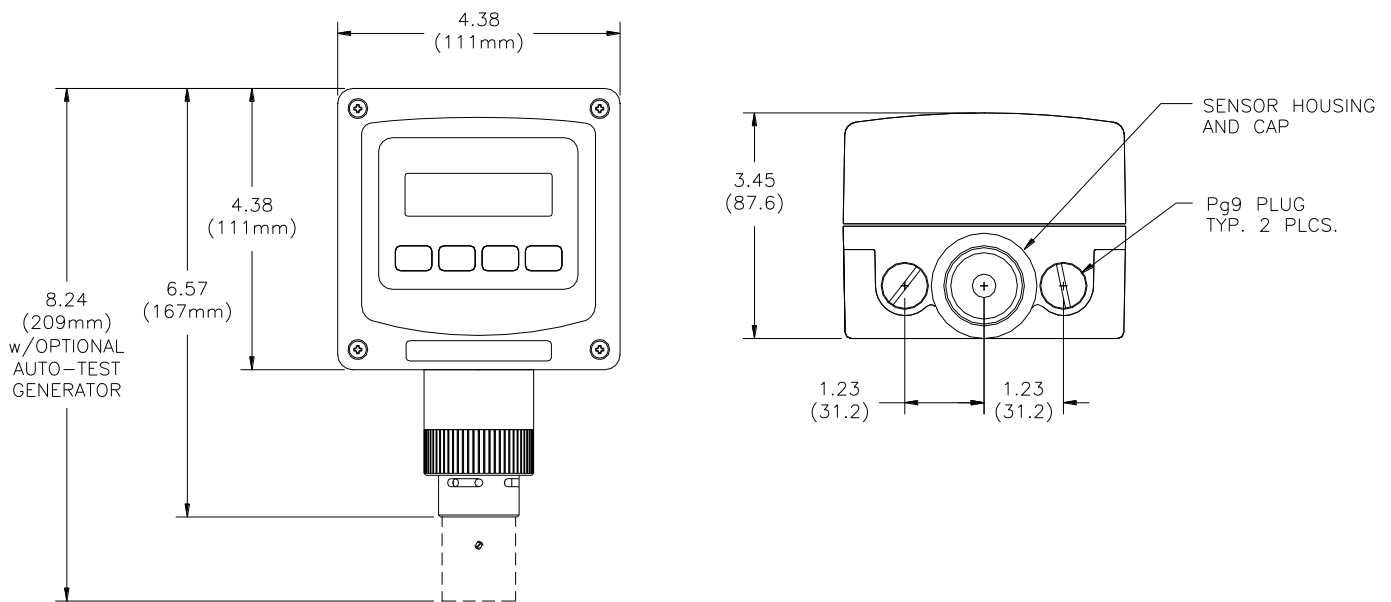

Figure 2. Enclosure dimensions, (RS485 no relays)

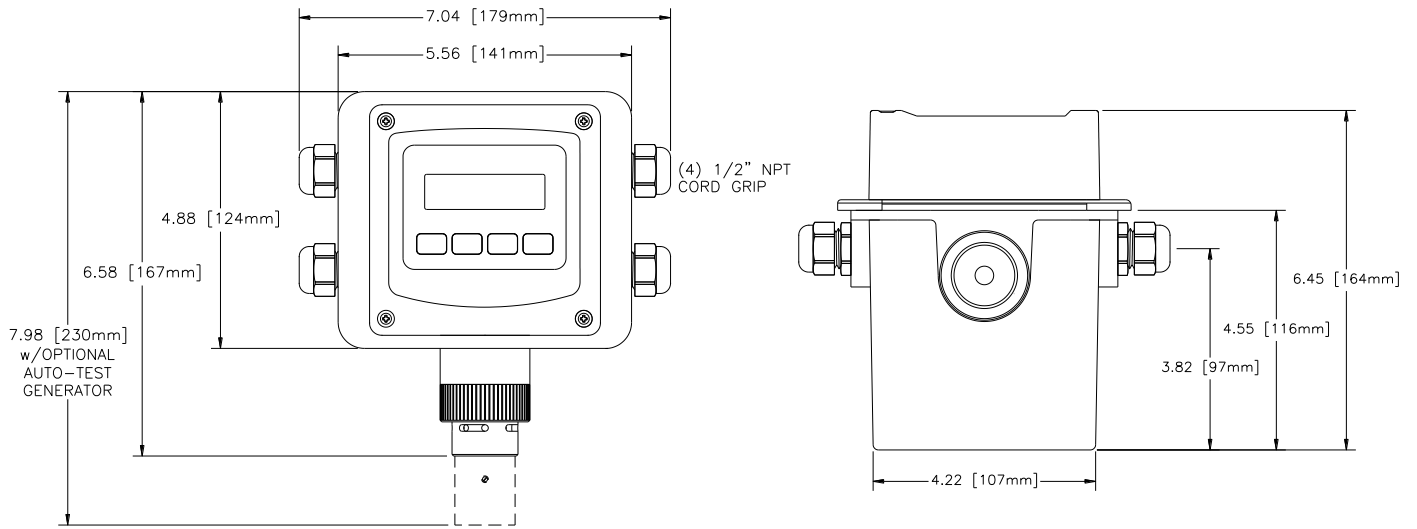

Figure 3 Deep Enclosure dimensions

2.3 Wall and Pipe Mounting

A PVC mounting bracket with attachment screws is supplied with the transmitter. The transmitter is attached to the bracket using four flat head screws, and the bracket is attached to a wall or pipe by way of the four slots in each corner. The slots will accommodate 1/4" u-bolts designed for 1 1/2" or 2" pipe. For 1 1/2" pipe, type 304 stainless steel u-bolts with 2" I.D. are available from ATI (p/n 47-0005).

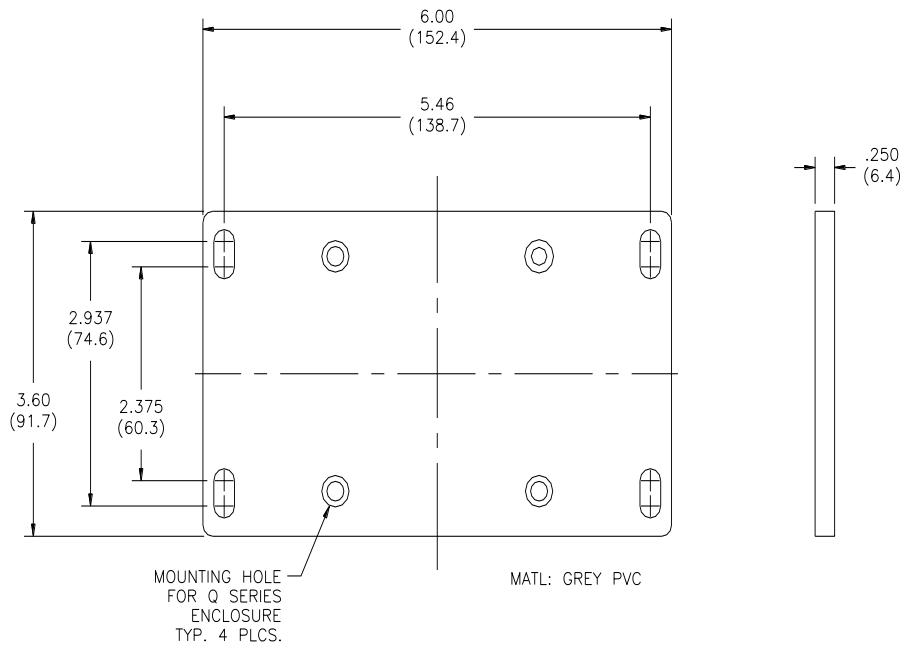

Figure 4 Wall/pipe mounting bracket

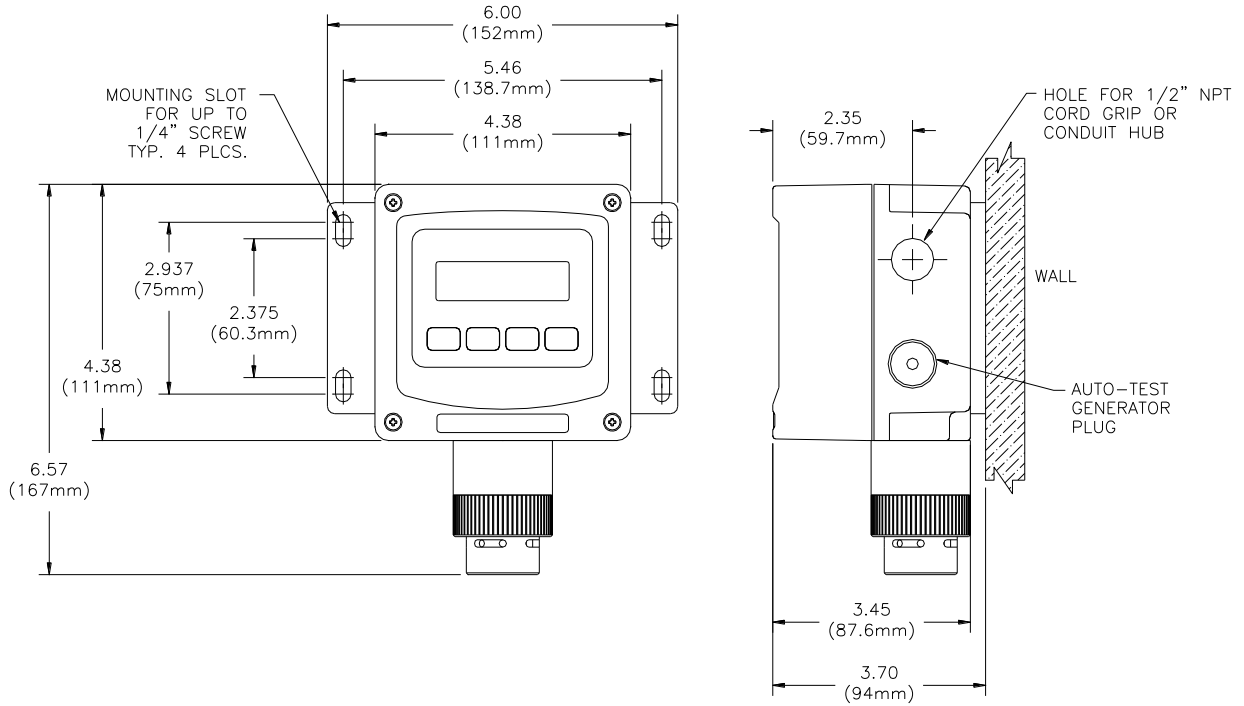

Figure 5. Wall mounting diagram

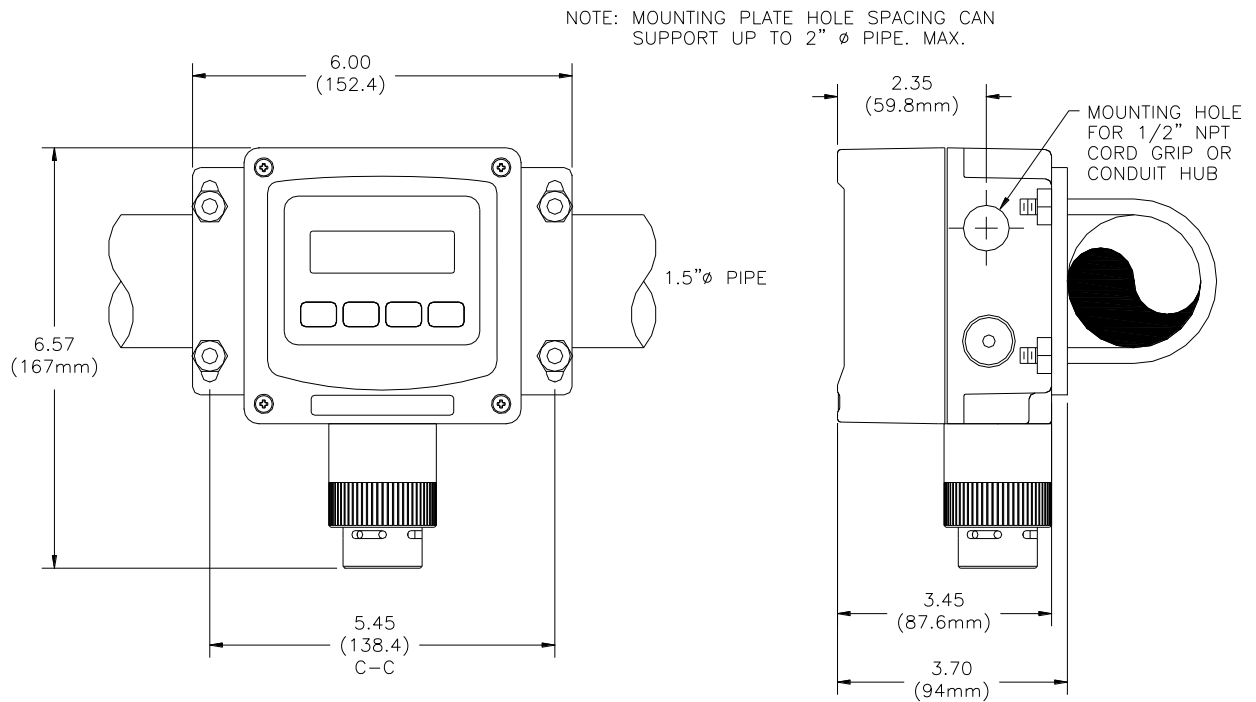

Figure 6. Pipe mounting diagram

2.4 Panel Mounting (Remote Sensors Only)

Figure 7 depicts the details for panel mounting the deep case. For this, a bracket attaches to the rear housing, and when adjusted, pulls the transmitter's flange down against the adhesive side of the gasket supplied with the bracket (make certain to remove the protective paper first).

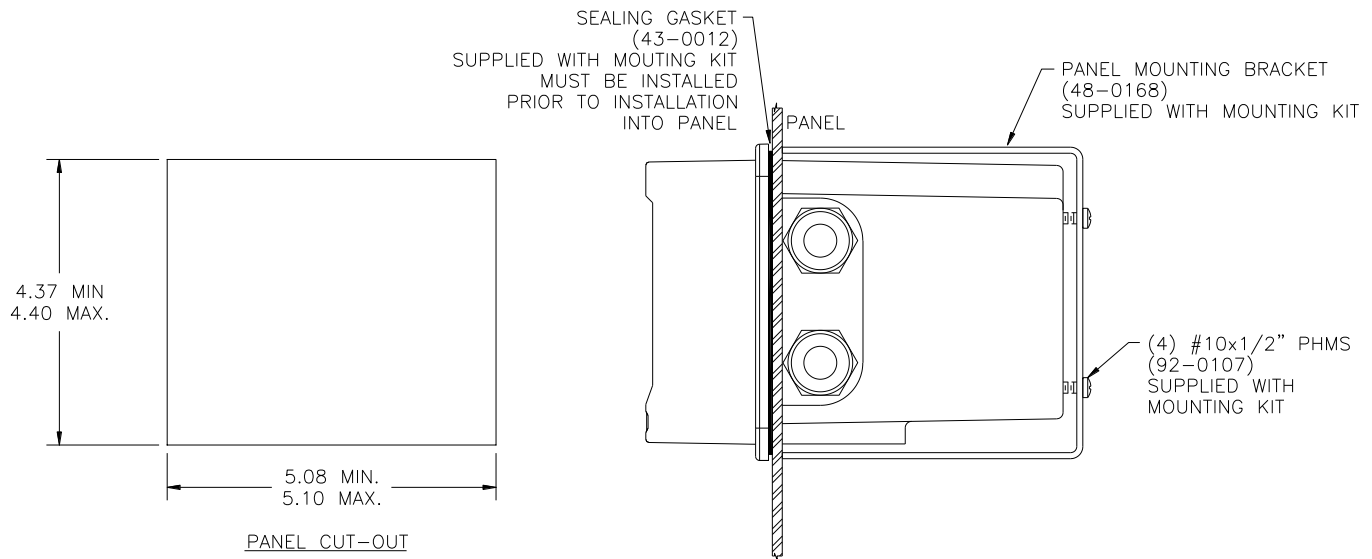

Figure 7. Panel mounting details [deep case]

2.5 Duct Sensor Mounting

The H10 sensor duct mount option allows sensors to be installed in a duct or pipe, and provides easy access for service.

The assembly is comprised of a special H10 sensor holder that slides into the hollow duct mount adapter (See Figure 9). The adapter has 1-1/2" MNPT threads on the insertion end, for securing it to the duct or pipe, and a barb fitting for supplying calibration gas to the sensor. An interface cable is provided to connect the sensor holder to the transmitter. Note that a mating flange for securing the adapter is not provided.

Screw the adapter into the duct or pipe so the barb fitting is accessible to connect gas tubing. Once the adapter is in place, slide in the sensor holder, lock it in place, and connect the interface cable. It is recommended that the sensor not be installed in the holder until you are ready to start the transmitter. This is especially true during construction, when excessive dust and dirt may be blowing through the duct system and be deposited on the sensor.

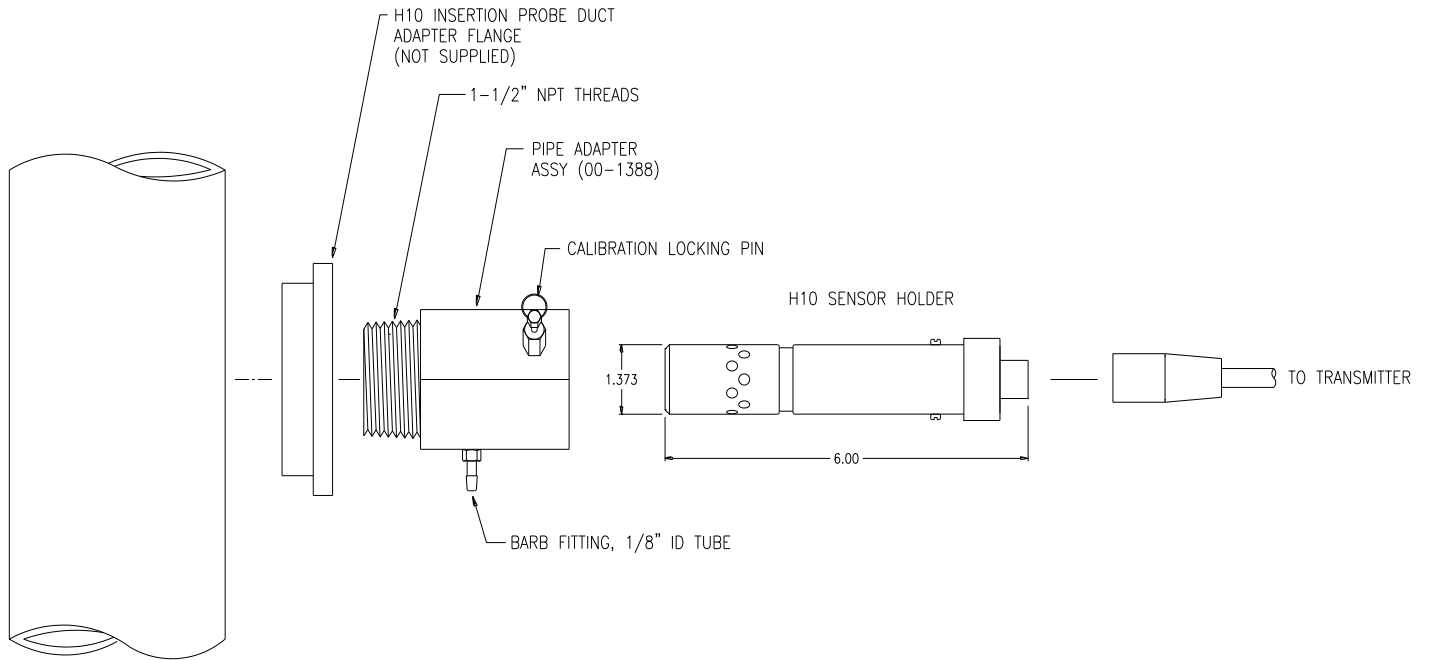

Figure 8 Duct Mount Sensor Exploded View

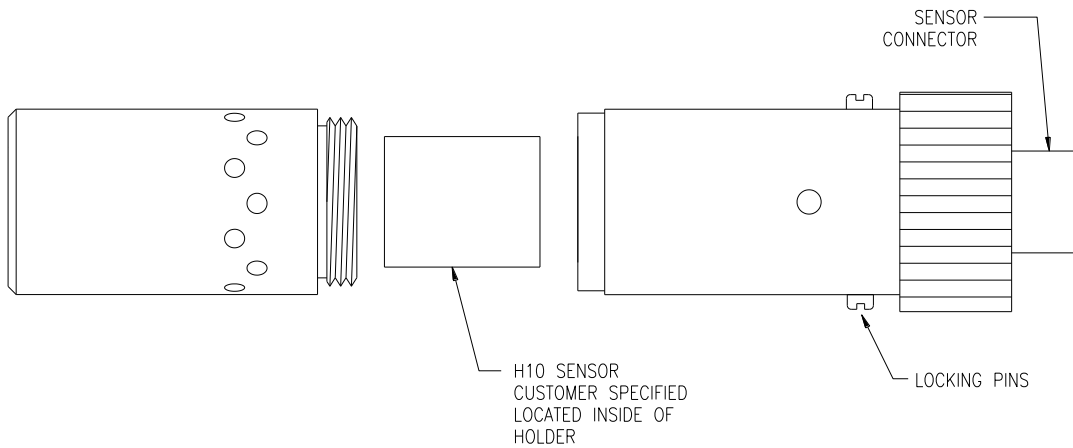

Figure 9. Duct-mount assembly

2.6 Duct Mount (Integral)

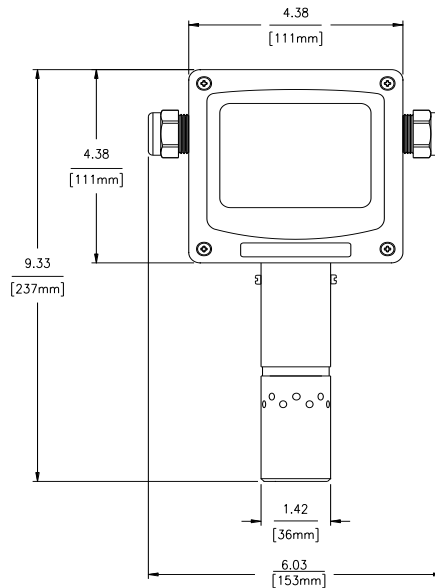

Figure 10 - Duct Mount (Integral) Transmitter Dimensions

2.7 Generator Installation/Removal

Generators are inserted into the optional generator housing attached to the bottom of the sensor housing at the base of the transmitter. Before installing the generator, check to see that the set screw on the side of the holder is loose and does not contact the generator during installation. An indexing groove on the side of the generator aligns the connector for a perfect fit. Once installed apply a little pressure to the top of the generator, and tighten the set screw (using the ATI screwdriver) on the housing to provide a secure fit. If the set screw is not secure, the connector on the generator may disengage causing a “generator missing” error message on the display.

To remove the generator from the holder, loosen the set screw on the side of the holder and pull up on the outlet stem.

An O-Ring in the sensor cap provides the mechanism for securing the generator to the transmitter. Simply press the generator into the bottom of the sensor cap until it is secure.

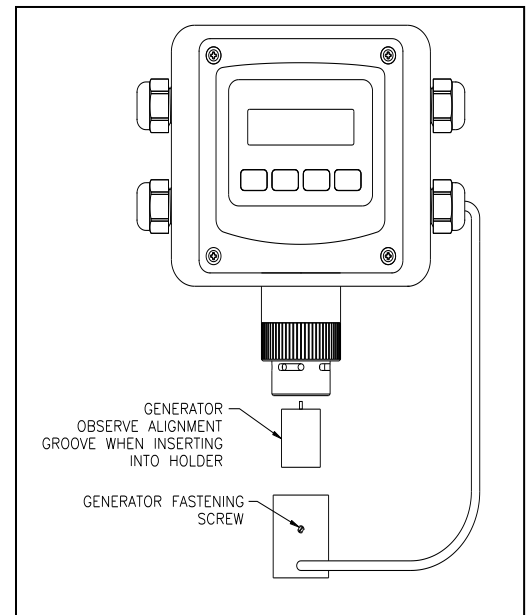

Figure 11 - Generator Exploded View

Part 3 – Electrical Connections

3.1 Transmitter Connections

WARNING:

Installation must be in accordance with the recognized standards of the appropriate authority in the country concerned.

To access the wiring terminals inside the transmitter, loosen the four screws in each corner of the housing's front cover. The front cover is hinged to the rear cover along its lower edge so it will swing down and stop at approximately 90°. The transmitter has limited space for wire; therefore, use the smallest gauge wire available that is compatible with electrical code and current requirements.

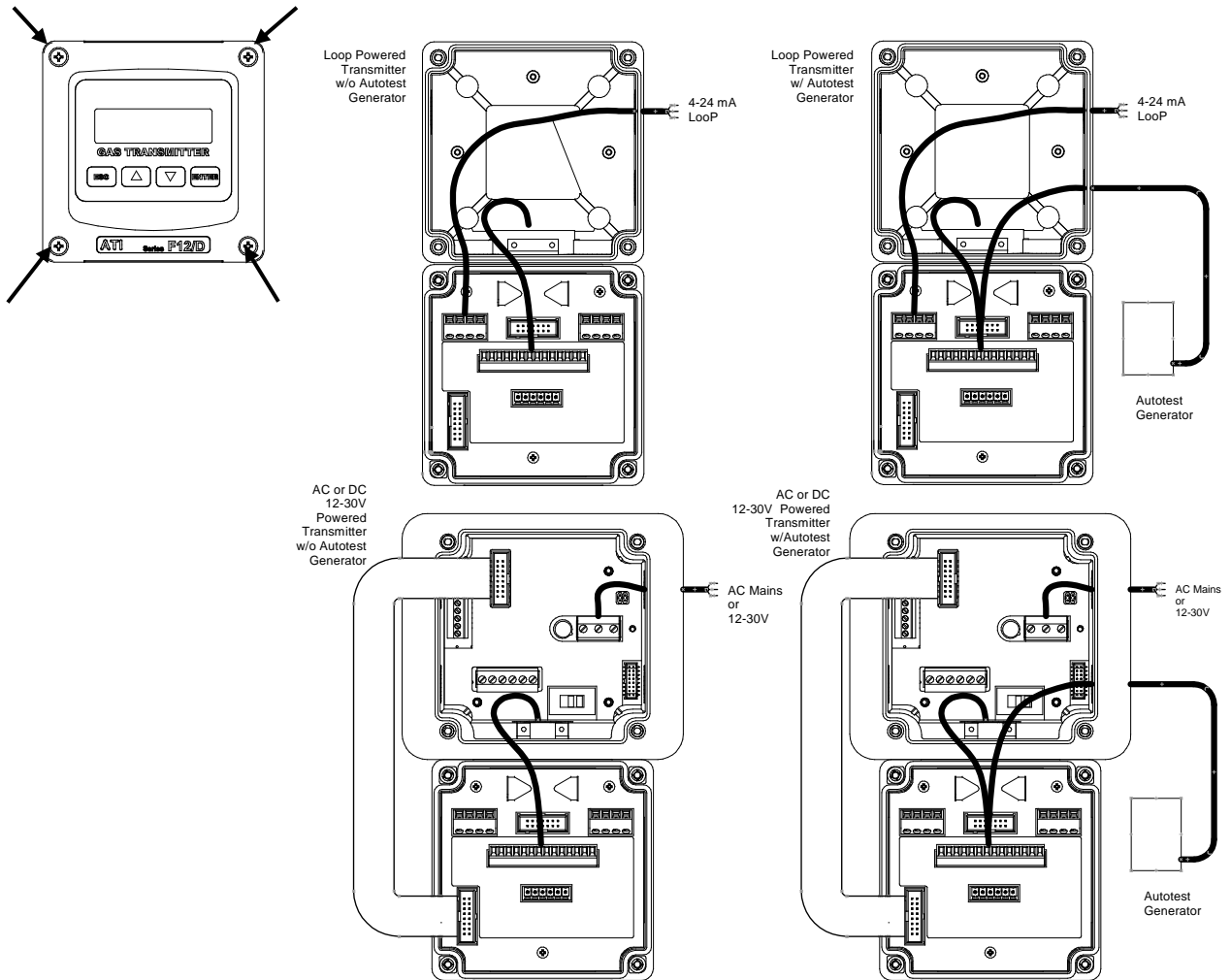
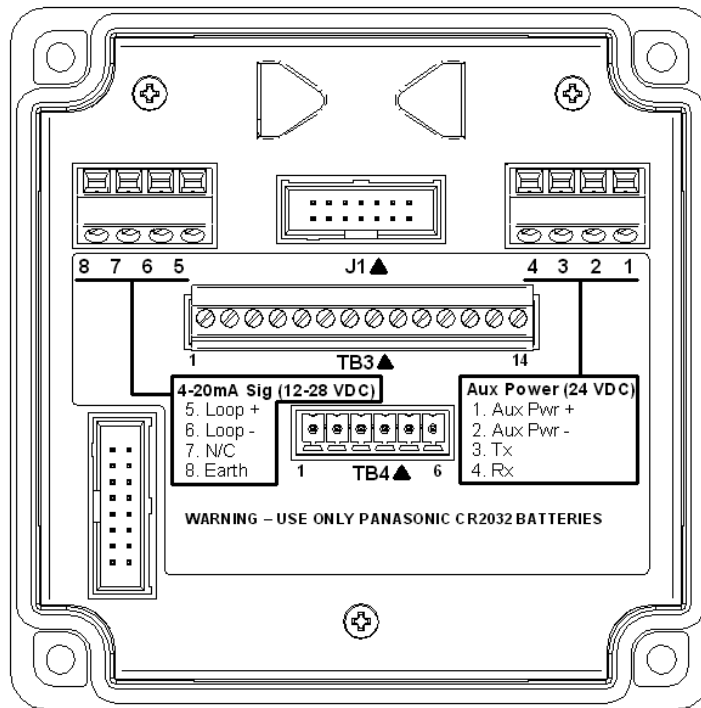

Figure 12. F12/D Transmitter Configurations

3.2 Terminal Board - Sensor Connections

The Terminal Board is located just below the metal shield in the front cover. It contains the power and communication terminals, and provides a header for connecting the Sensor Housing wires and optional Autotest Generator wires.

The table below lists connections for the Sensor Housing and Autotest Generator wires.



Conductor colors

TB 3 Position	Sensor Wires	Generator Wires
1	WHITE	
2	YELLOW	
3	BLUE	BLUE
4	PURPLE	WHITE
5	GRAY	
6		GREEN
7	BLACK	
8	BROWN	BLACK
9	RED	RED
10	ORANGE	ORANGE
11		WHT / BLK
12	GREEN	
13	PINK or RED	
14	PINK or RED	

Position 13 & 14 are for Heated Sensor option. Colors will vary depending on heated style ordered

Figure 13. Sensor/Generator Terminal Wiring

3.3 Terminal Board – Loop Power Connections

The Loop Powered transmitter model is powered in using terminals 5 and 6 commonly referred to as “two-wire mode”.

Loop Powered models with the heated sensor housing and/or MODBUS communications option require an additional 24 VDC supply to power them. This auxiliary power is connected to terminals 1 and 2.

Note: Connections to the communications on the DC Powered models are made on the power supply board.

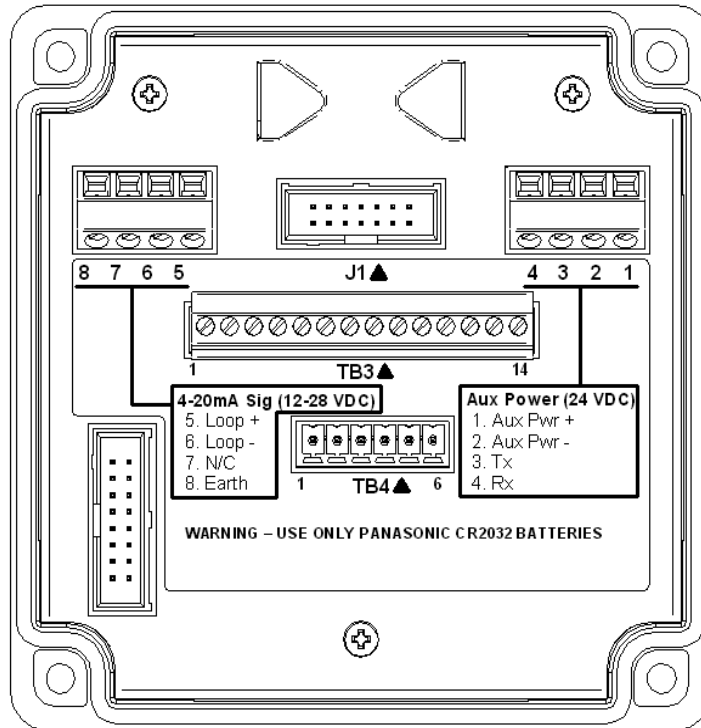

Power Terminals	
1	Auxiliary Power +
2	Auxiliary Power -
3	Comm. Tx
4	Comm Rx
5	Loop +
6	Loop -
7	Comm Common
8	EARTH GROUND

Figure 14. Power and communication terminals.

3.4 Heated Sensor Housing Wiring

The AC Powered and DC Powered models contain a power supply to create the power necessary for the optional Heated Sensor Housing.

The two pink wires from the heated Sensor Housing connect to terminals 5 and 6 of the AC or DC Power Supply PCB.

TRANSMITTER AC OR VDC POWERED VERSION

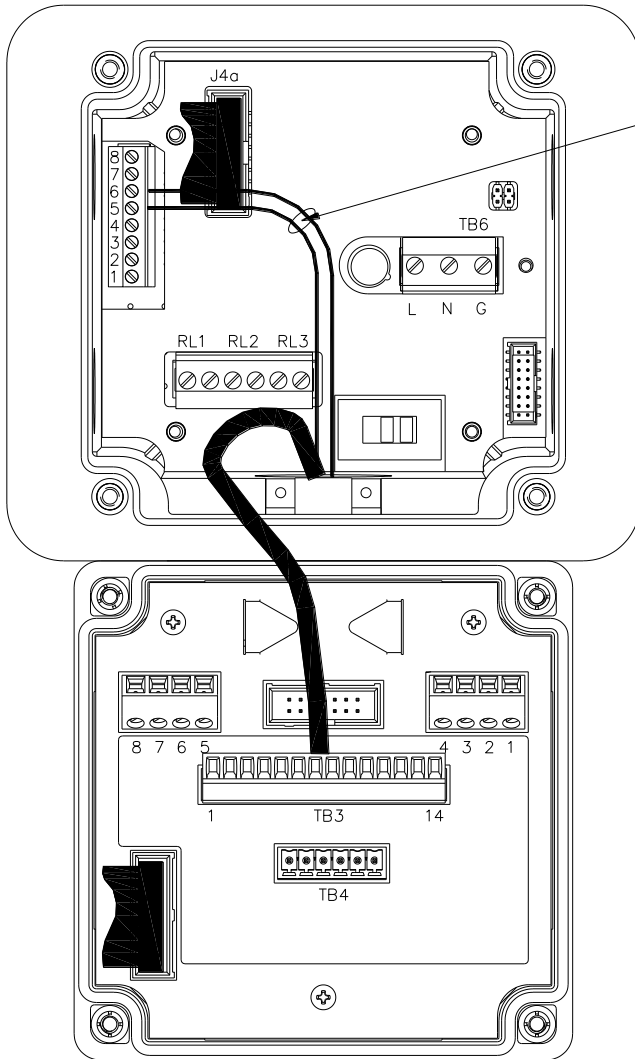

IF USING CLOSE COUPLED HEATED SENSOR (00-1699), WIRE COLORS WILL BE PINK

IF USING 6 FT. HEATED SENSOR (00-1878), WIRE COLORS WILL BE RED.

Conductor Colors		
T/B Pos	Sensor Wires	Generator Wires
1	WHITE	
2	YELLOW	
3	BLUE	BLUE
4	PURPLE	WHITE
5	GRAY	
6		GREEN
7	BLACK	
8	BROWN	BLACK
9	RED	RED
10	ORANGE	ORANGE
11		WHT / BLK
12	GREEN	

Figure 15 - Heated Sensor Wiring Diagram

3.5 Remote Sensor Wiring

The remote sensor option permits the sensor to be mounted up to 100' from the transmitter. Remote interconnect cable sold separately. The interconnections are shown below.

Notes:

- The shield must be connected only at one end. Preferably at the Transmitter end
- Use shielded 4 conductor (2 twisted pairs) cable
- Loop Powered model shown. Interconnections for AC and VDC powered models are similar to Loop powered model.

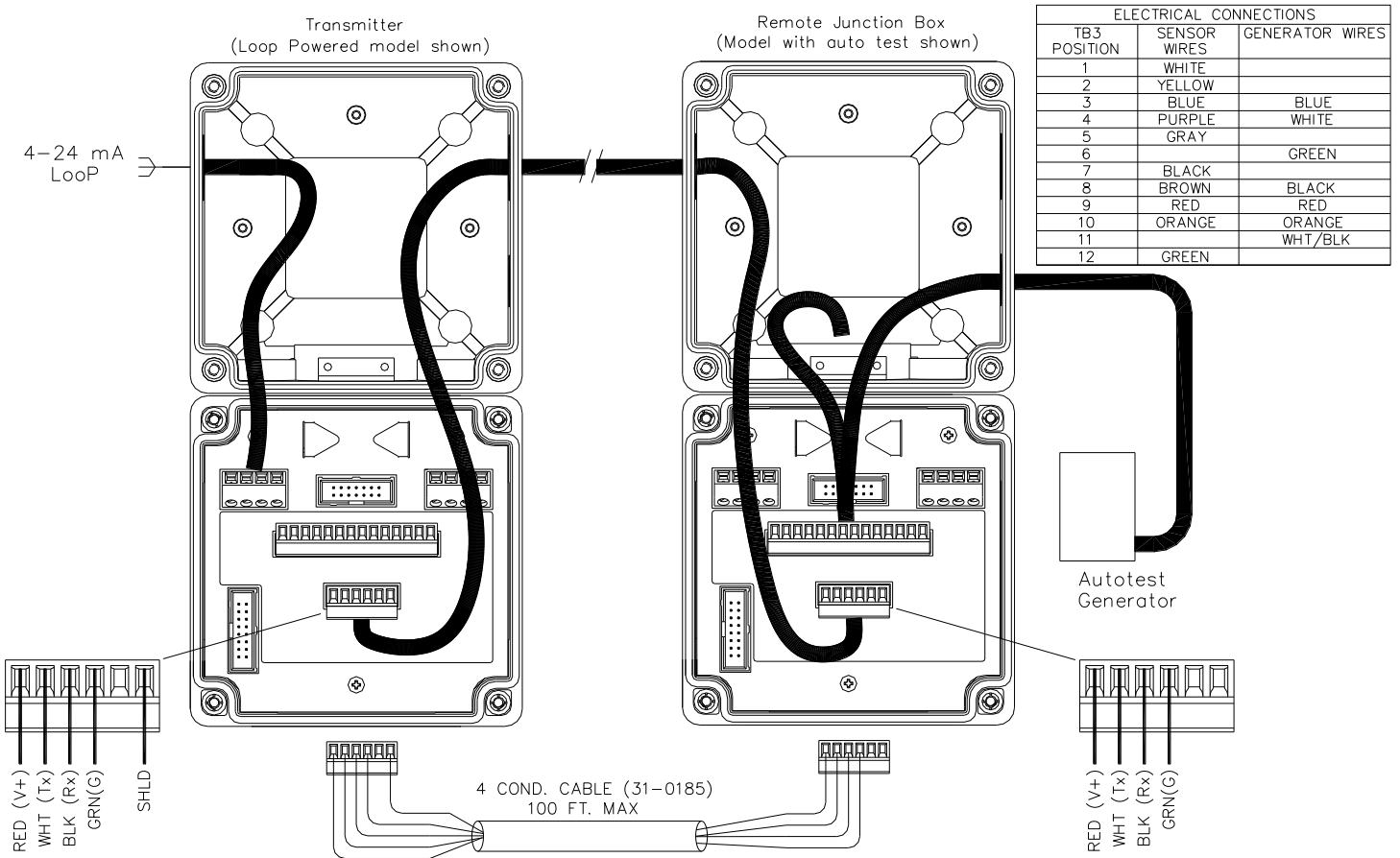

Figure 16–Remote Sensor wiring

3.6 Heated Sensor Wiring (AC or VDC Powered) - Remote

The heated remote sensor option requires an additional 2 wires between the transmitter and the remote junction box. The interconnections are shown below.

Notes:

- The shield must be connected only at one end. Preferably at the Transmitter end
- Use shielded 6 conductor (3 twisted pairs) cable (Pairs **MUST** stay together), or run the lines for the sensor heater separately

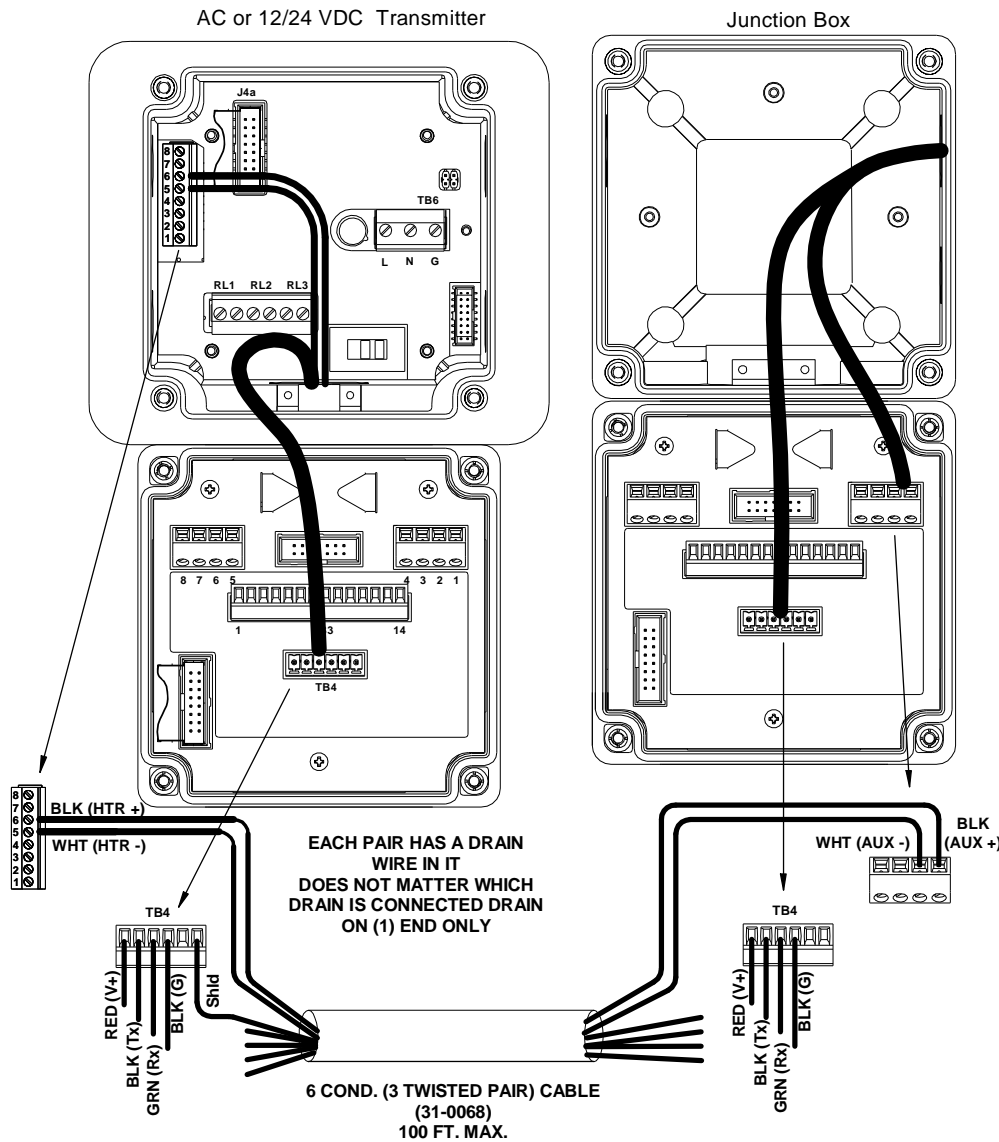

TB3	SENSOR WIRING	GENERATOR WIRING
1	WHITE	
2	YELLOW	
3	BLUE	BLUE
4	PURPLE	WHITE
5	GRAY	
6		GREEN
7	BLACK	
8	BROWN	BLACK
9	RED	RED
10	ORANGE	ORANGE
11		WHT/BLK
12	GREEN	
13	*PINK	
14	*PINK	

*If using the 6 ft. Heated Sensor (00-1878), Red wires will replace the Pink wires listed above

Figure 17 – Remote Sensor wiring

3.7 Heated Remote Sensor Wiring (2-Wire)

The heated remote sensor option requires an additional 2 wires between the transmitter and the remote junction box. The interconnections are shown below.

Notes:

- Rx of the Transmitter must be connected to Tx of the Junction box
- Tx of the Transmitter must be connected to Rx of the Junction box
- The shield must be connected only at one end. Preferably at the Transmitter end
- Use shielded 6 conductor (3 twisted pairs) cable, or run the lines for the sensor heater separately

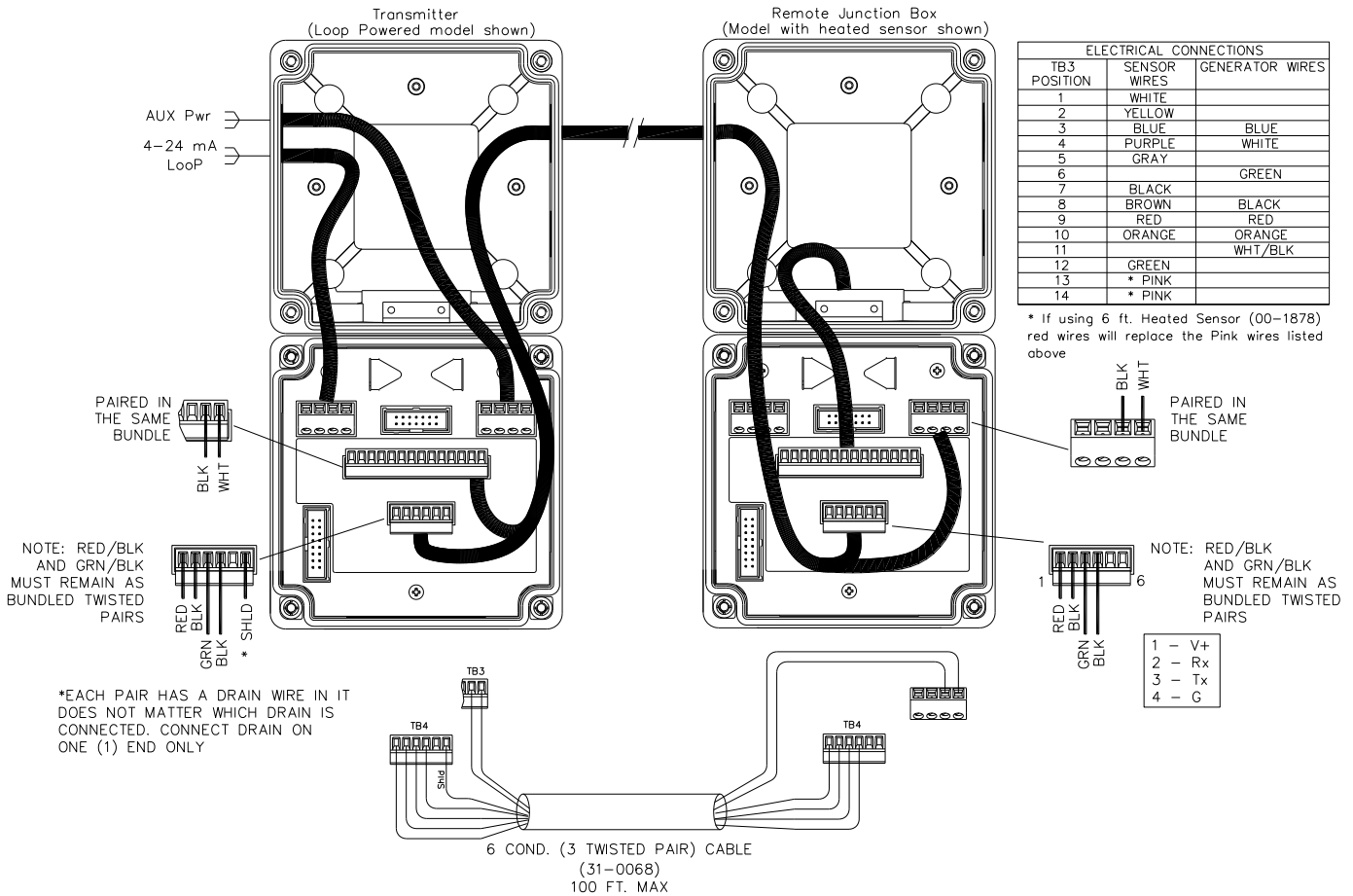

Figure 18 – Heated Remote Sensor wiring

3.8 Duct Mount Sensor Wiring

The Duct Mount Sensor option permits the sensor to be mounted into a process flowstream.

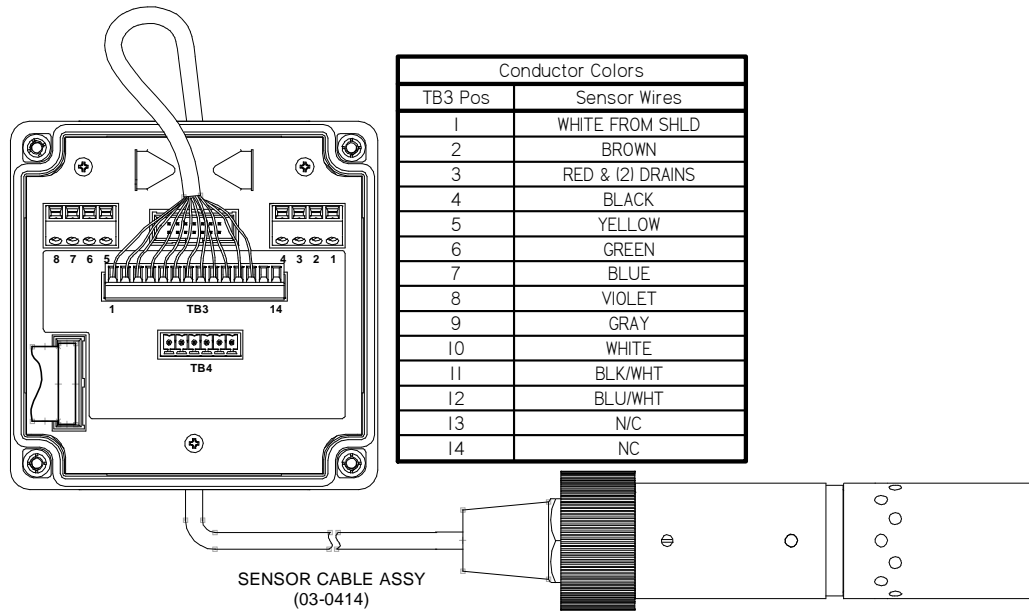

Figure 19 – Duct Mount Sensor Wiring

3.9 Sensor Connections with 6 Ft cable

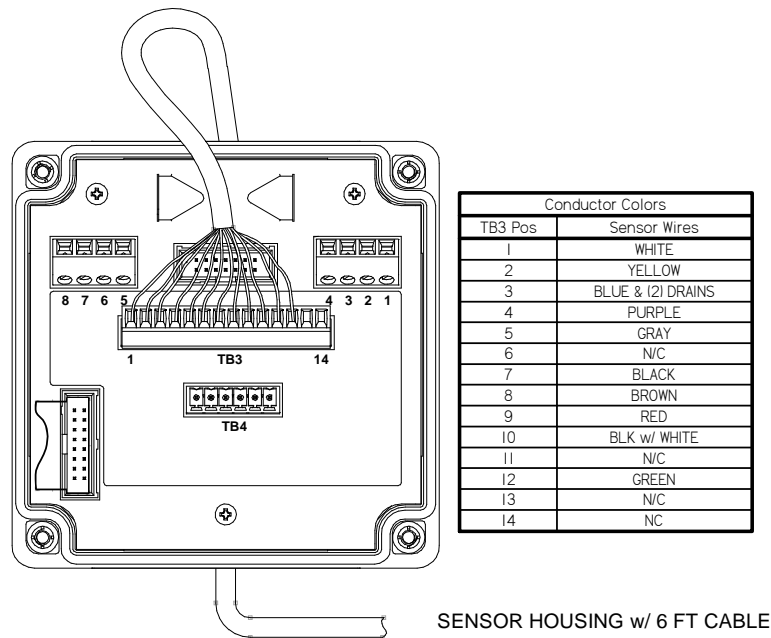

Figure 20 – Wiring connections – 6 ft sensor cable

Alarm Relay Boards (Option)

The Alarm Relay board is available in both an AC powered and DC powered version. Each version features three SPST relays, an external remote alarm reset, and provides power to the transmitter and communication interface. A 20-conductor ribbon cable connects control signals and power between the transmitter and the relay board. Relay operation must be enabled through the operator interface.

Signaling on the 20mA current loop, including HART FSK, is still possible by connecting a separate power supply and current loop receiver to terminals 5 and 6 on the P/S Board.

3.10 AC or 12-30 VDC Powered

The AC powered version requires 115 or 230 VAC at 50-60Hz applied to TB6. DC powered units require 12-30 V between terminals 1 and 2 of TB6.

NOTE: The Voltage selector switch must be be set to match the AC power supplied.

The switch is marked with '115' and '230'. The unit is configured for 115 VAC when the '115' is visible on the switch. If the incorrect voltage is shown, simply slide the switch to the other position.

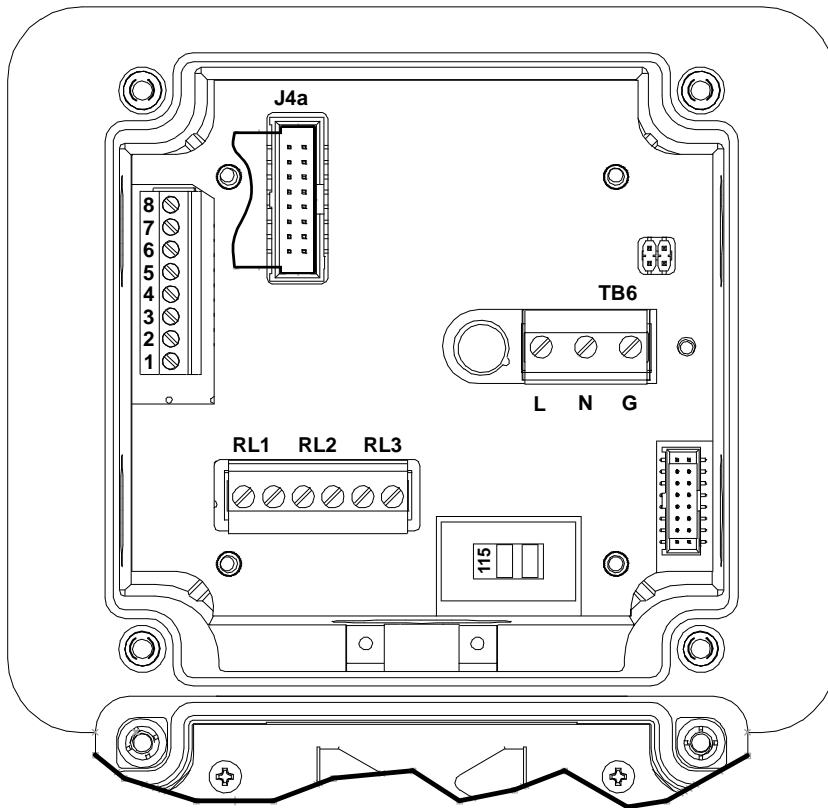

J4a
CONNECTS TO (AUX)
ON FRONT LID

TB3
1 - RL1 Contact NO
2 - RL1 Contact C
3 - RL2 Contact NO
4 - RL2 Contact C
5 - RL3 Contact NC
6 - RL3 Contact C

TB5
8 - Loop Power (-)
7 - Loop Power (+)
6 - Heater Power (+)
5 - Heater Power (-)
4 - Pwr -
3 - Pwr -
2 - Remote Reset
1 - Pwr +

TB6 for AC Operation
(L) - 115/230 VA, 50/60 Hz
(N) - Neutral
(G) - Ground

TB6 for 12-30 VDC Operation
(+) - V+
(-) - V-
(G) - Ground

Figure 21 - Powered Alarm Relay Contacts

3.11 Relay Configuration

By default, RL1 and RL2 are under the control of the transmitter’s gas concentration alarms. The C (common) and NO (normally open) contacts of relays RL1 and RL2 are jumpered to TB3 and are open when their respective coils are de-energized (i.e., no gas alarm or no power). In contrast, RL3 is under the control of the transmitter’s fault alarm, which is programmed to keep the relay coil energized until a fault is detected (or power fails). The C and NC (normally closed) contacts of relay RL3 are jumpered to TB3 so it is closed when the coil is de-energized. The default configuration may be modified cutting and reconnecting jumpers on the Alarm Relay board, and by changing variables via the operator interface.

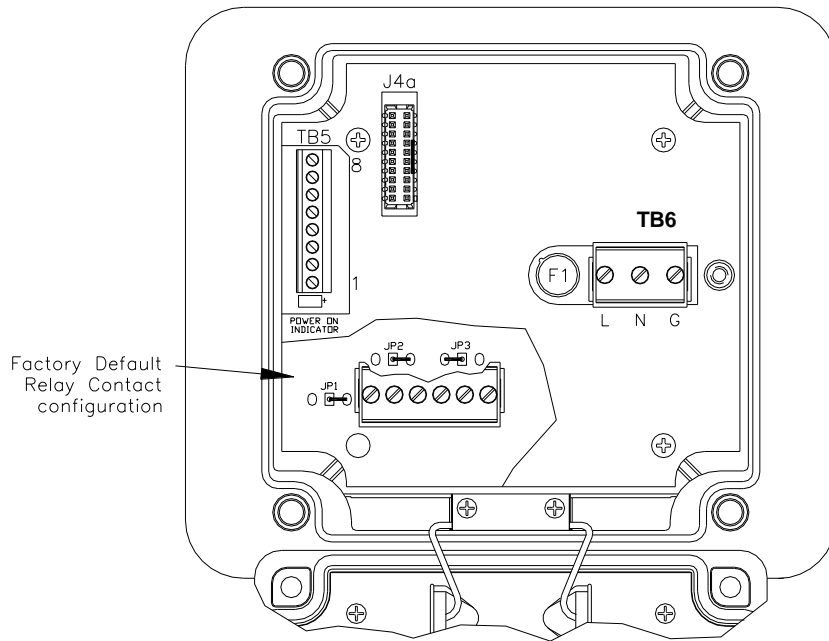

Figure 22 - Relay Configuration Jumper Location

Relays are best used as pilot relays if heavy load switching is desired. Use suitable arc suppression devices across loads switched through internal relays.

3.12 Remote Reset Input

The remote reset inputs on pins 2 and 3 of TB5 are used to clear alarms requiring manual reset. The function is activated when the two contacts are momentarily shorted together.

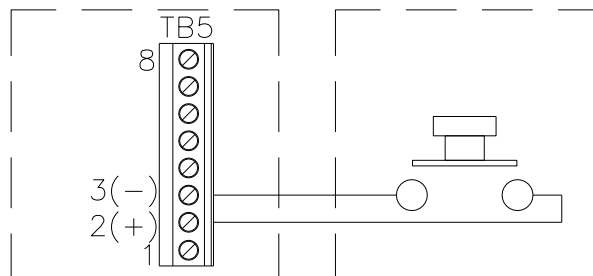

Figure 23 – Remote Reset Input

3.14 Wiring Examples

ATI A17/B14 Receiver(s)

Up to two transmitter/receivers may be connected to a single A17 power supply.

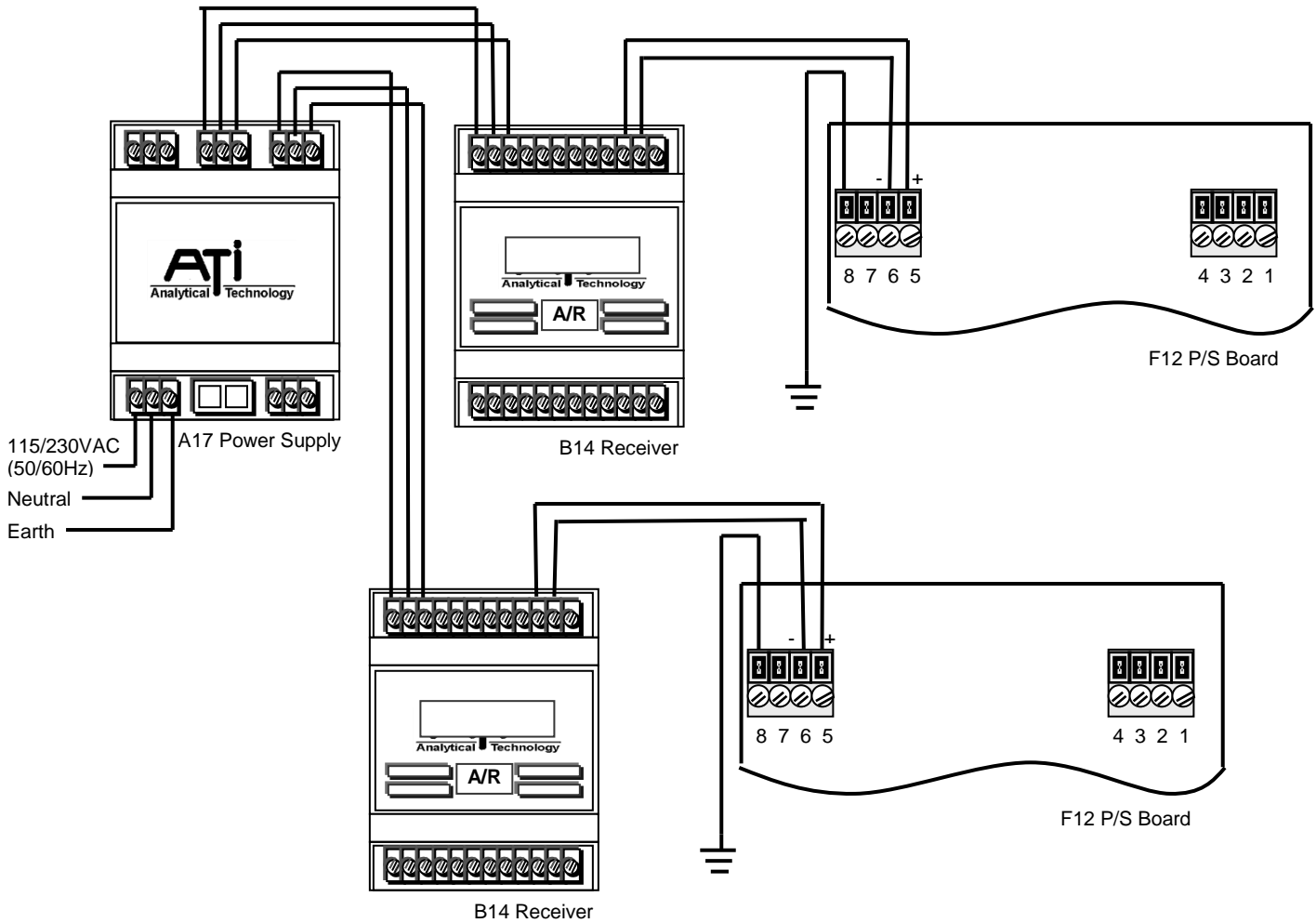

Figure 24 - ATI A17/B14 Receiver Modules

RS485 Transmitter with 4-20mA Signaling to A17/B14 Receiver

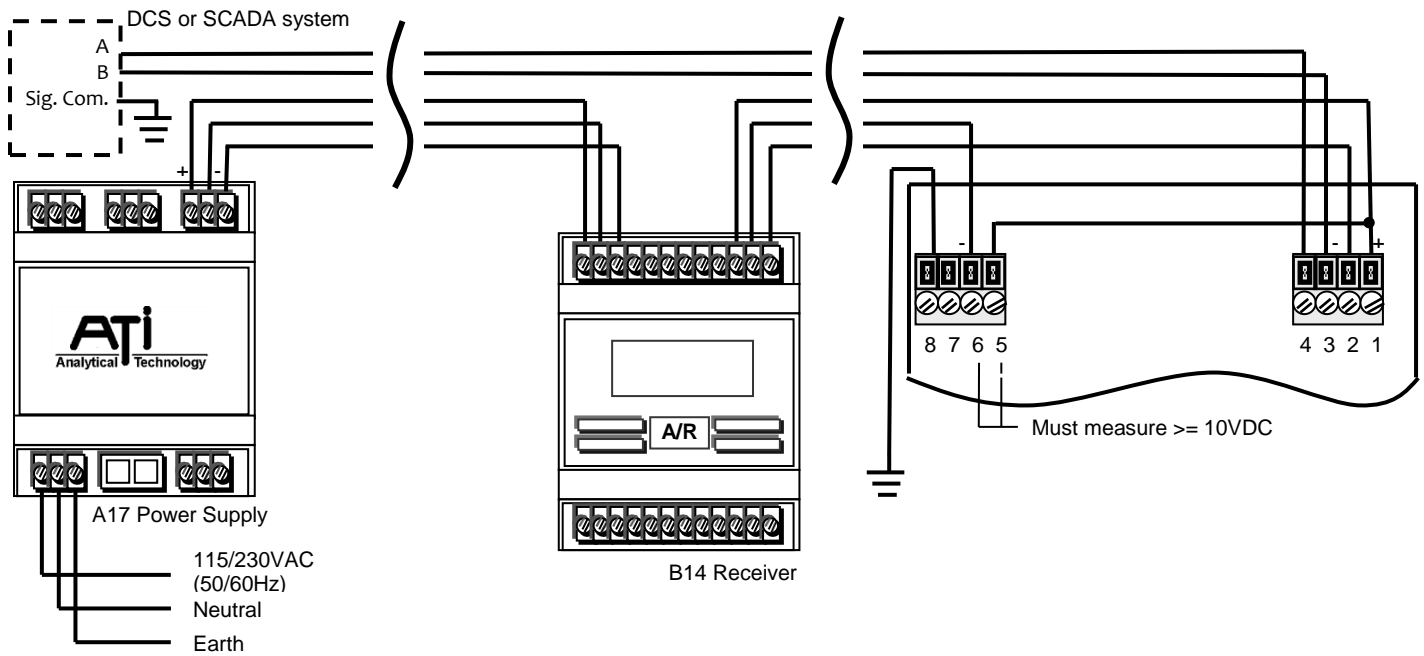

Figure 25 - RA485 Multidrop w/4-20mA signaling

RS485 Multidrop Network without 4-20mA Signaling

The ATI A17 power supply module may be used to power up to four F12/D transmitters connected in an RS485 network. Use an appropriate gauge wire to minimize supply voltage drops (must not drop below 10v at any transmitter).

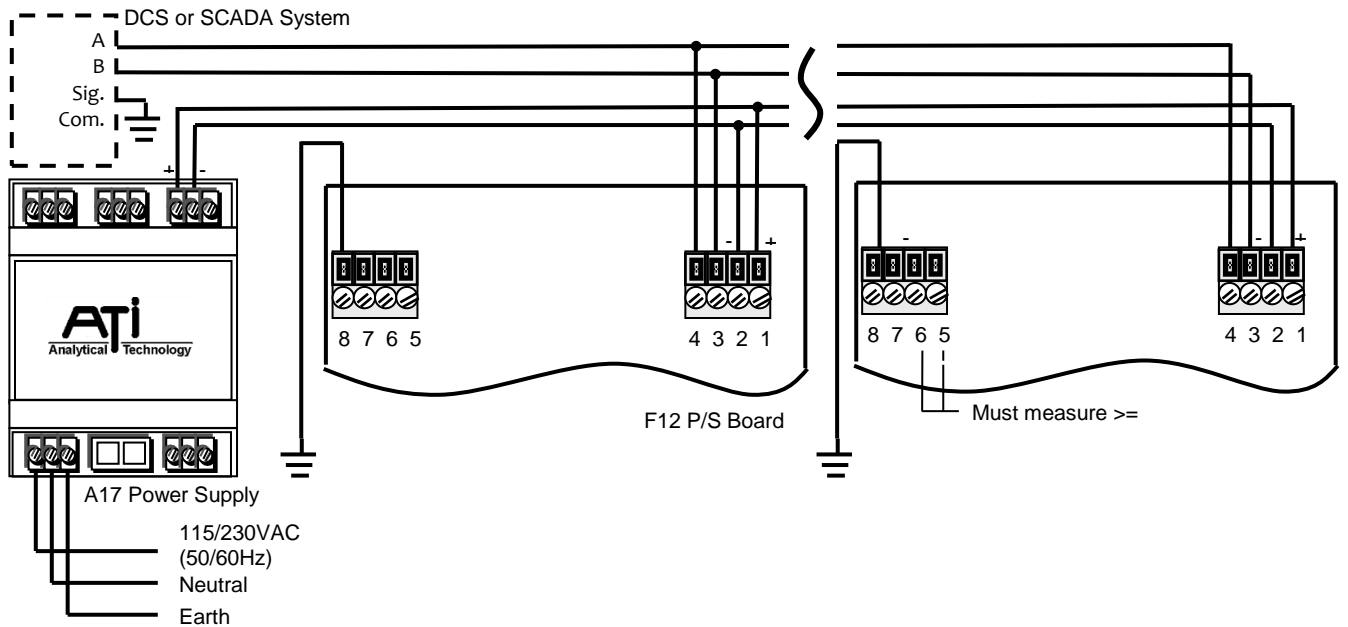

Figure 26 - RS485 Multidrop w/o 4-20mA signaling

3.15 Powered 4-20 mA Output

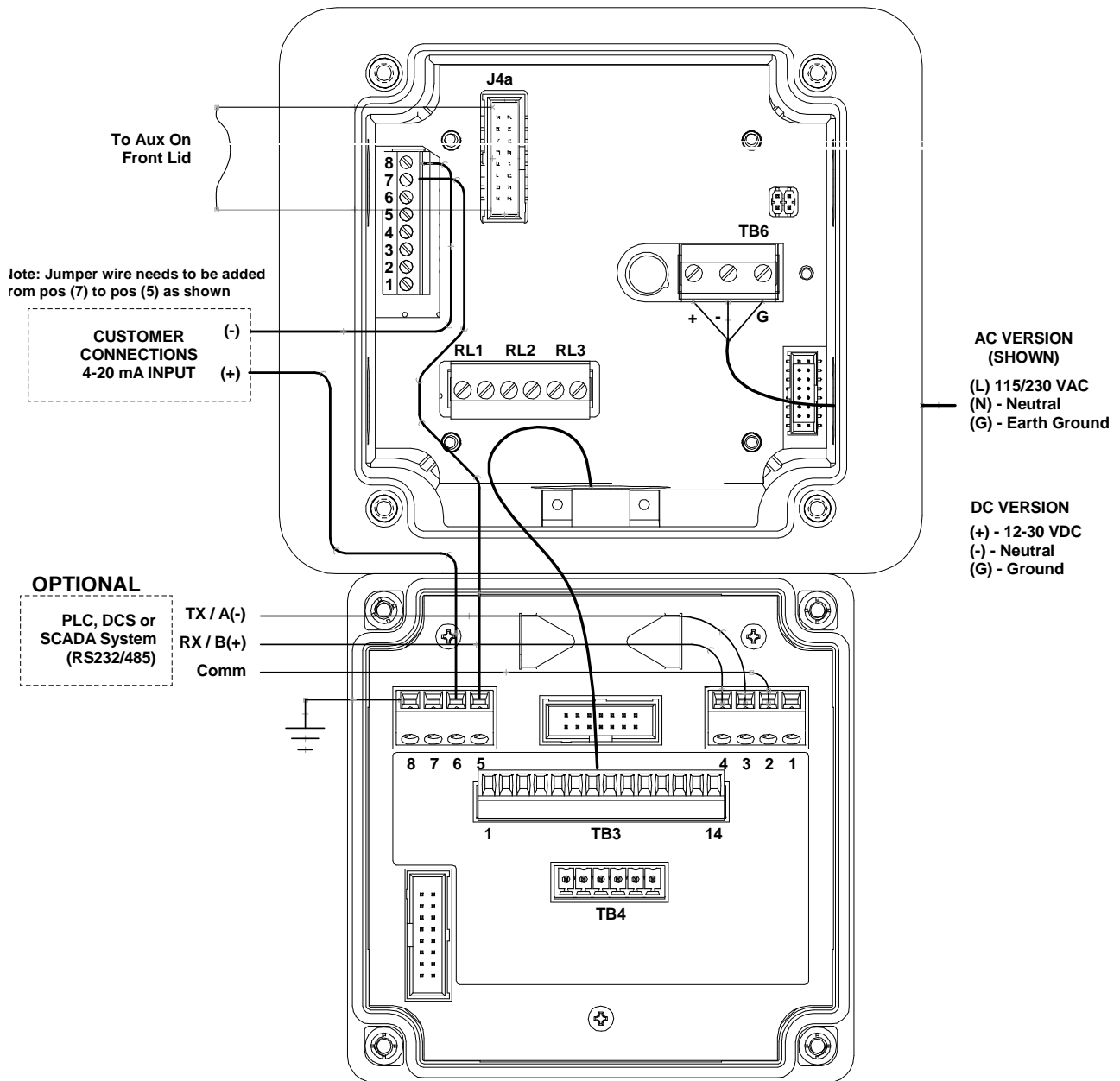

Figure 27 – AC or 12-30 VDC Powered Relay Board Wiring

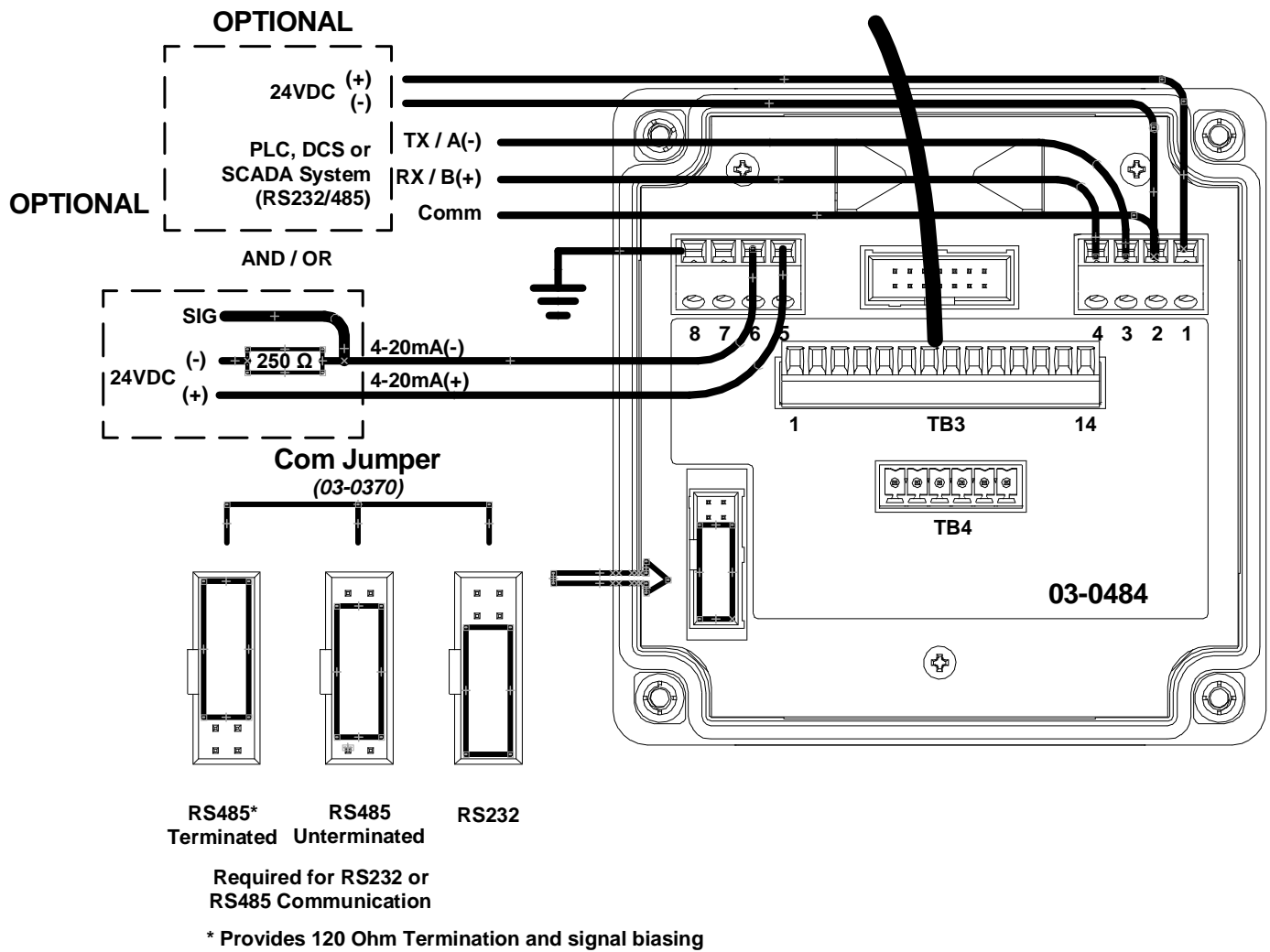
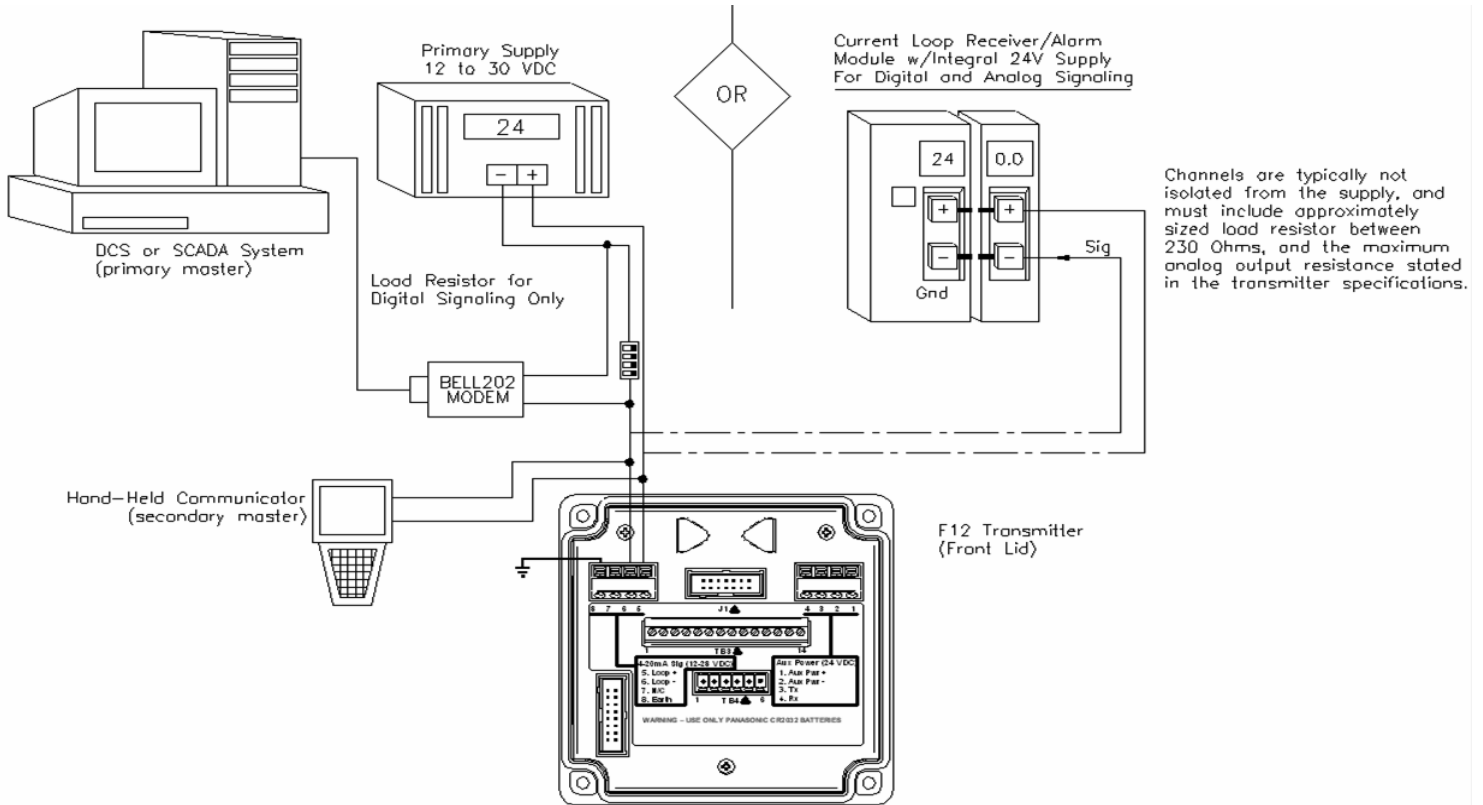

Figure 28 – Communication w/4-20 Loop Output

3.16 HART Point-to-Point (2-Wire)

The HART “Point-to-Point” connection permits the transmitter to communicate digitally, while retaining the functionality of its 4-20mA current loop. Setting the transmitter’s polling address to 0 permits the current loop to function normally. According to HART specifications, the current loop must be terminated with a load resistor between 230 and 1100 ohms; however, transmitter specifications restrict the maximum analog output resistance to a lower value (see Specifications). The term, “active source”, refers to a transmitter that is not loop powered, and sources current from power applied to it on separate terminals. Size the power supply according to the number of transmitters, the current demand of each transmitter (see specifications), and wire resistance. Wire resistance must not be allowed to drop the Primary Supply Voltage below 10V at the terminals of any transmitter. Hint: use at least 14 AWG wire on supply connections



(shown in bold).

Figure 29 - HART Point-to-Point (2-Wire)

3.17 Communications Jumper Setting

Units with an optional communications interface use a jumper to select between RS-232, RS-485, and RS-485 with termination. The desired physical interface is set by positioning jumper JP5 as shown below. The orientation does not matter, only its position.

Protocol	Alignment
RS-232	Top (toward JP5 label)
RS-485 Unterminated	Middle
RS-485 With termination	Bottom (away from JP5 label)

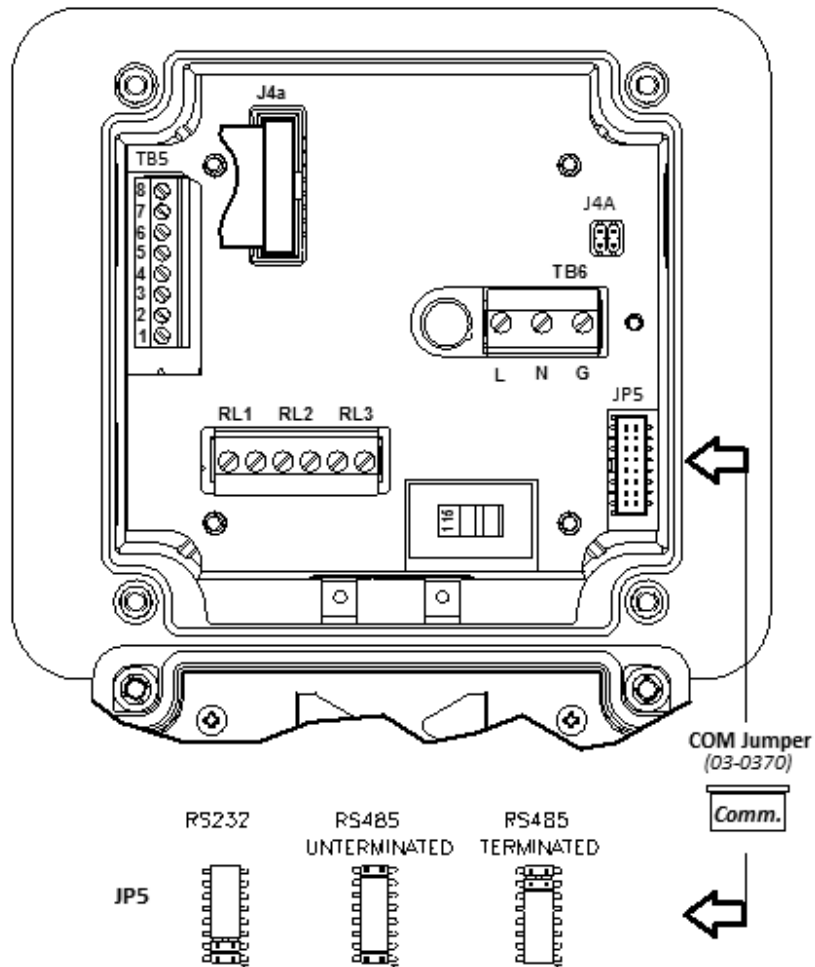

Figure 30. Comm. Interface Jumper

Part 4 - Operation

4.1 Operator Interface Panel

The F12/D operator interface is non-intrusive, so you do not have to remove the housing cover to view the display, configure the transmitter, or calibrate the sensor. It features a backlighted, transfective 96x32 dot LCD display and four panel keys.

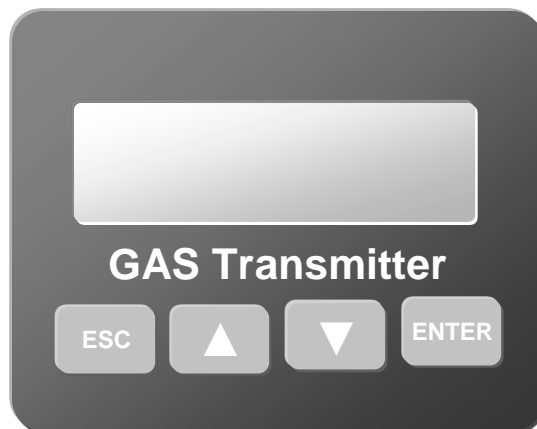

Figure 31. Operator interface panel

Menus and Settings

Items appearing on the display are usually text labels that identify the name of a menu or a setting. Menus are typically a single text label, like "Menu", while settings are typically composed of a text label and a value field separated by an equal sign, like, "Range= 50.0".

Moving the Cursor and Selecting

The up (▲) and down (▼) keys are used to move the selection cursor (◆) between displayed items. The down key typically moves the cursor down, or to the right, while the up key moves the cursor up, or to the left. Pressing the **Enter** key when the cursor is pointing at a menu label (ie, is to the left of the label) causes the transmitter to display the new menu and position the cursor at the first item. Pressing the **ESC** key at any item on the selected menu causes the transmitter to return to the previous display.

Editing Settings

A setting is selected for editing by moving the cursor to the left of the label and pressing the **Enter** key, which causes the up-down edit cursor (◆) to appear in front of the value. Pressing the up key (▲) causes the value to increase or present the next list item, while pressing the down key (▼) causes the value to decrease or present the previous list item. Once the setting has been adjusted to the desired value, pressing the **Enter** key stores the new value and exits edit mode. Pressing the **ESC** key restores the original value and exits edit mode.

While editing, the edit cursor changes its shape to provide feedback on which key is activate.



1	▶Range = 50.0	Move the selection cursor in front of the setting's label, and swipe the Enter key.
2	Range ◆50.0	The up-down edit cursor appears.
3	Range ▲ 50.1	Pressing the ▲ key increases the value.
4	Range ▼ 49.9	Pressing the ▼ key decreases the value.
5	Range ✕ 100.0	Pressing the Enter key saves the new value and exits edit mode.
6	▶Range = 50.0	Pressing the ESC key restores the old value and exits edit mode.

Figure 32. Example Edit

4.2 Startup

Transmitter Review

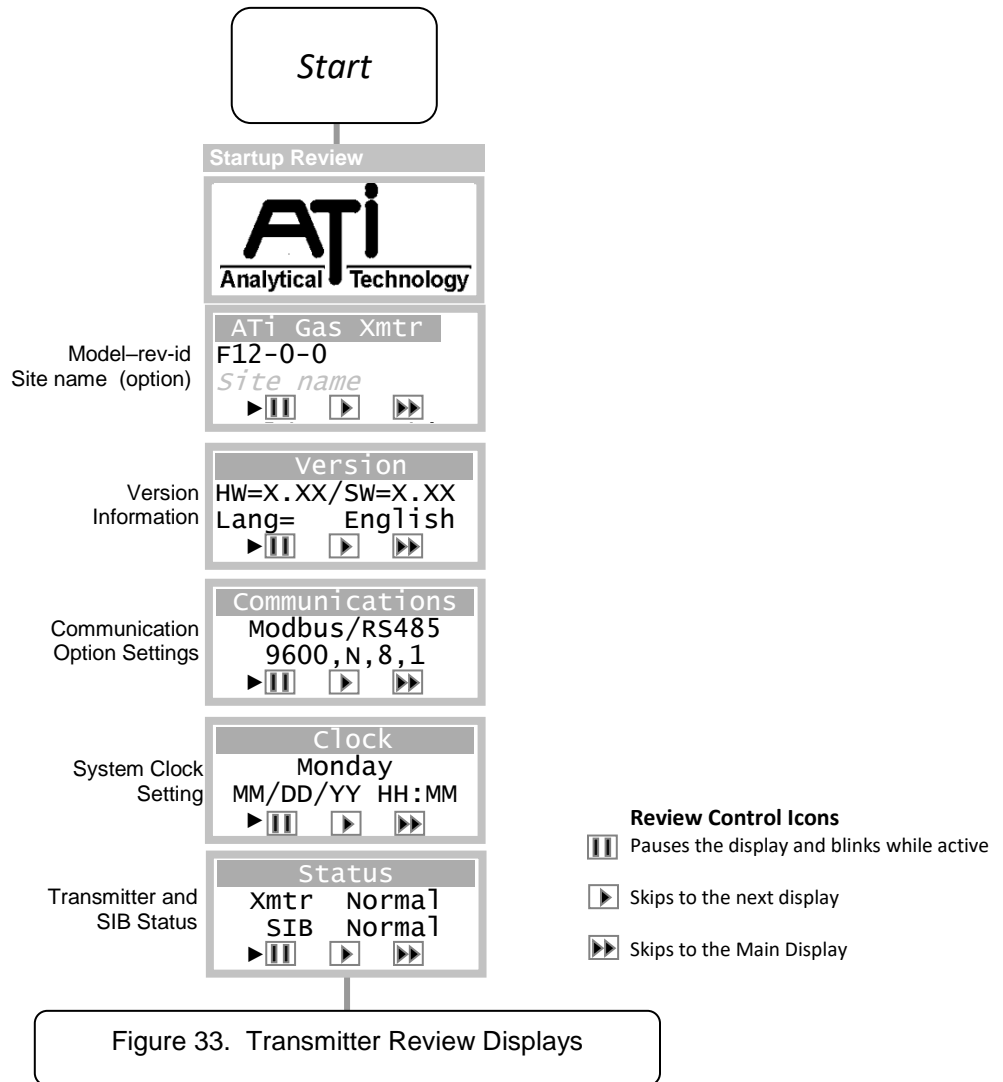

Sensor Review

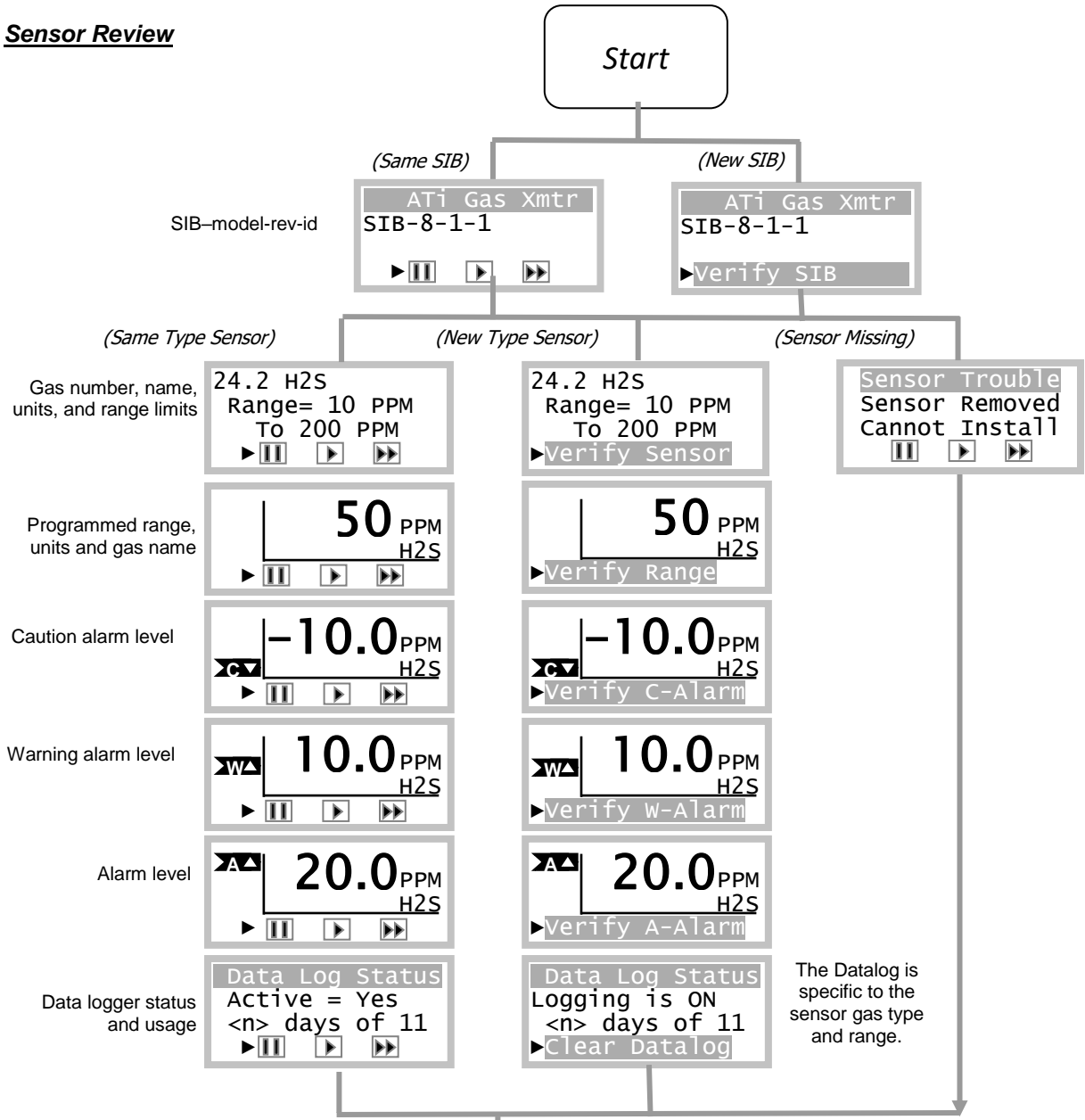

- Review Control Icons**
- ⏸ Pauses the display
 - ▶ Skips to the next display
 - ▶▶ Skips to the Main Display

Operator Verify
Review pauses indefinitely at: Verify SIB, Verify Sensor, Verify Range, Verify C-Alarm, Verify W-Alarm, Verify A-Alarm, and Clear Datalog. The Trouble alarm is activated after 5 minutes of no keypad activity.

Figure 34. Sensor Review Display

Generator Review

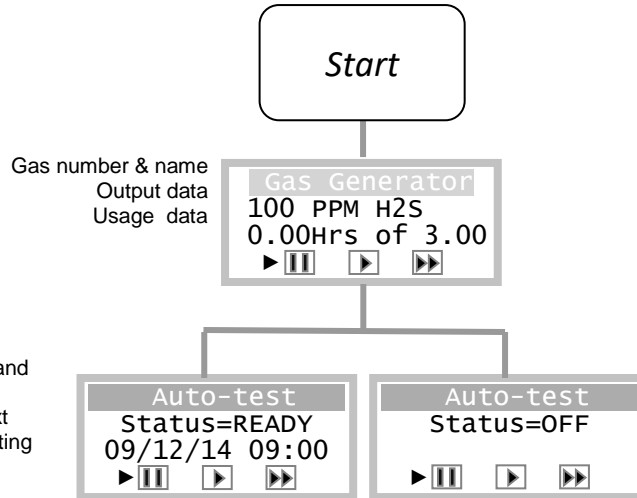

When the Auto-test status is READY, and no problems are detected with the generator, the date and time of the next automatic test is advanced, so that testing is held off for at least 24 hours (see Sensor Auto-test).

Figure 35 - Generator Normal Review

When the Auto-test status is READY and a generator is not installed, or has a problem (Read Error, Wrong Gas Type, or Under-range), a message is displayed along with a prompt to disable Auto-test. If not selected, or if a compatible generator or sensor is not installed within 5 minutes, a Trouble alarm occurs, at which time the 4-20mA output is 3.6mA (default value), and the Trouble alarm relay is active. The Trouble alarm must be cleared by selecting "Disable", or by replacing the generator.

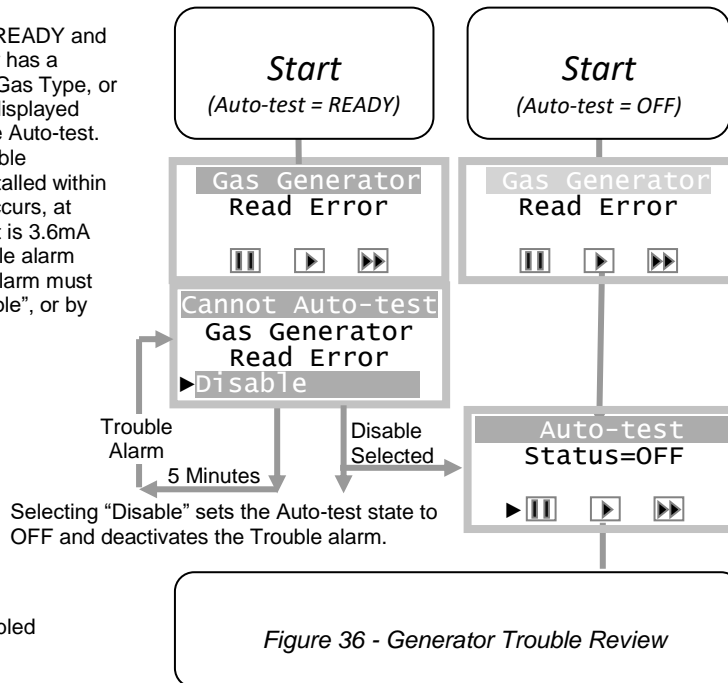

When the Auto-test status is OFF and a problem is detected with the generator (Read Error, Wrong Gas Type, or Under-range), the problem is displayed, but no Trouble alarm occurs, and no operator intervention is required. However, an exception will be displayed when attempting to start Auto-test, or set Auto-test to READY.

NOTE: Auto-test is never automatically enabled or disabled without operator intervention.

Figure 36 - Generator Trouble Review

4.3 Main Display

The Main Display Page shows the name and concentration of the target gas, and units of measurement (PPM, PPB, %, etc). Indicators on the left and below show alarm and operating status.

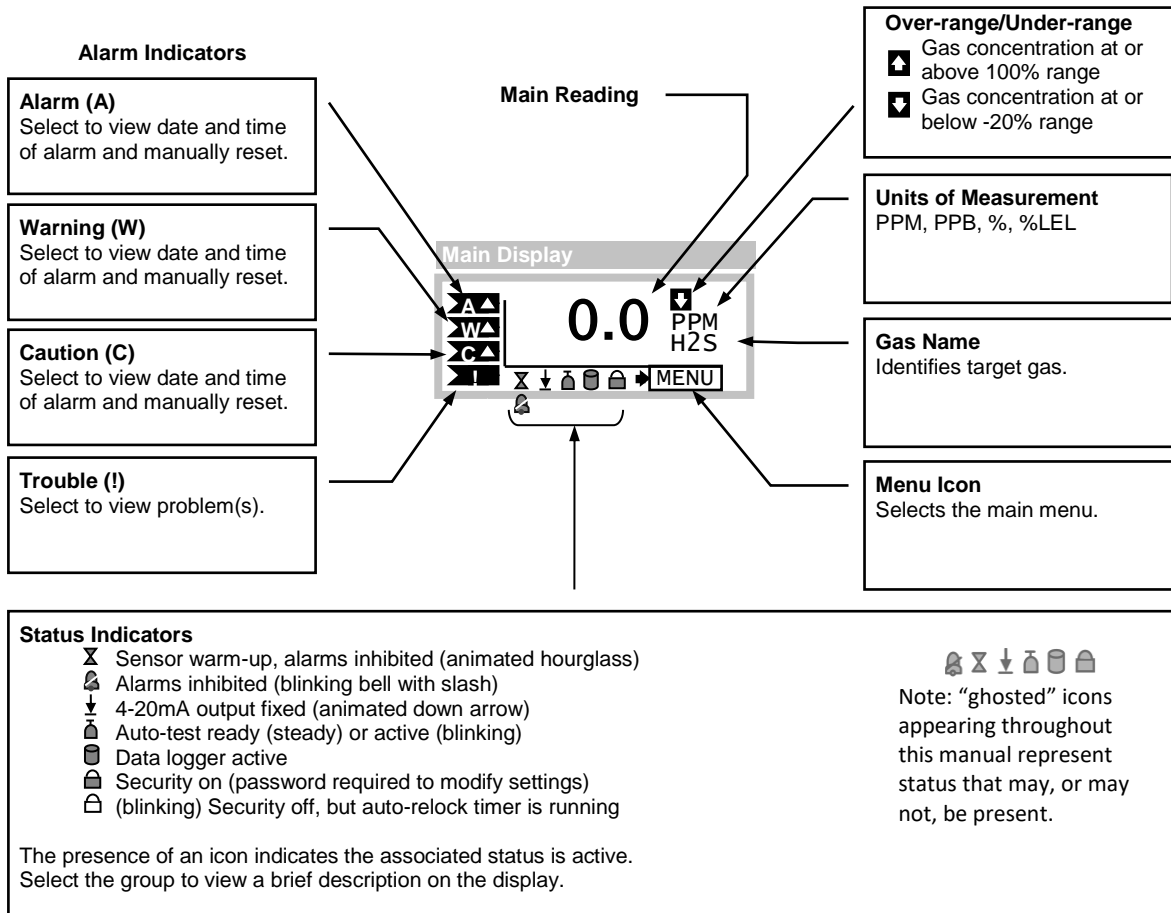

Figure 37. Main Display

Main Reading

The main reading represents the gas concentration value and appears on the Main Display, along with the gas name and units of concentration, and is reported on the 4-20mA output^{1,2}. By default, it is blanked to suppress the display of negative values. That is, the reading is reported as zero if the concentration drifts below zero, which can occur over time as a result of sensor aging. If the concentration falls to -20% of the full-scale range, a trouble alarm is generated. Blanking is typically extended slightly above zero, as a means of stabilizing the reading in the presence of excessive external noise, or other environmental factors (see Sensor Settings Menu on pg 39). During zero and span calibration, the "un-blanked" gas concentration value is displayed, primarily to assess the amount of positive or negative drift.

¹ The 4-20mA may not match the reading when the ⏴ status indicator is visible on the Main Display, or when the output is in a physical limit.

² Throughout this manual, "ghosted" status icons are used to indicate status that may be present or not present.

Trouble Indication

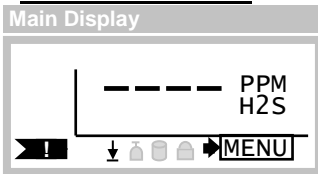

The Trouble alarm is indicated by four dashes appearing on the Main Display, along with the (!) flag in the lower left corner, and the 4-20mA status icon indicating that the 4-20mA output is fixed (default = 3.6mA).

Figure 38. Main Display Trouble Indication

Timed Return to Main Display

Menus and other pages used for configuring the transmitter and sensor return to the Main Display after 5 minutes of no key activity. Exceptions to this behavior include the zero and span calibration pages.

Inhibiting Alarms from the Main Display

Pressing the ESC key for 3 seconds, then releasing, toggles the alarm inhibit mode. If alarm inhibit was off, it is turned on for 15 minutes (default value). If alarm inhibit was on, it is turned off, and in addition, the sensor warm up period is expired immediately (see status indicators above).

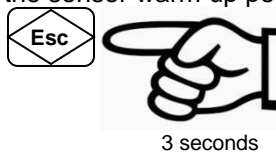

4.4 Pop-up Displays

Sensor Removed Display

Removing the gas sensor causes the transmitter to “pop-up” the Sensor Removed Display (below), which displays a count-down timer. During this time, alarms are inhibited and the current loop output is fixed at 4.0mA (17.4mA for Oxygen sensors). A trouble alarm will occur if a sensor is not installed before the timer expires. This 60 second period is usually long enough to reinstall the sensor, or install a replacement, but if more time is needed, the count may be extended to 5 minutes by selecting “Reset”. Selecting “Exit” forces expiration of the timer and exits to the Main Display, which will then indicate the Trouble alarm is active (see Figure 38 above).



Figure 39. Sensor Removed Display

Sensor Installed

When a sensor is installed, the transmitter compares the type to the previously installed sensor. If they match, the previous sensor’s settings are copied to the new sensor, if necessary³. The transmitter then starts the sensor review as shown in

³ The transmitter sets the new sensor’s range, blanking, damping, and alarms to match the previously installed sensor, which might cause confusion when transferring sensors from field transmitters to shop transmitters for calibration. During review, the shop transmitter will display the settings of the previously installed sensor, which might not match the field transmitter. Fortunately, this is not a real problem. The sensor may be calibrated as normal, and when it is eventually returned to the field, the field transmitter will restore its original settings. Always verify settings of field transmitters.

. If the types did not match, the review halts and waits for the operator to verify the new sensor’s full-scale range, and alarm settings. After verifying the sensor, the transmitter copies the sensor settings to its local memory.

Sensor Install Effects on the Data Log

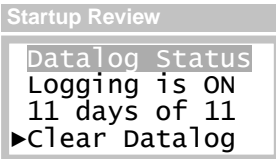

When the sensor is replaced with one of a different gas type (ie, a different part number), you are also prompted to clear the data log during review. Once the sensor is installed, the transmitter executes a 5-minute (typical value) warm-up period, during which alarms are inhibited, the 4-20mA output is held at 4mA (17.4mA for Oxygen sensors), and Zero, Span and Auto-test are not permitted.

Note



Changing the sensor gas type will clear the data log. Electro-chemical sensors may take up to 12 hours to stabilize if not stored in the sensor keeper.

Generator Removed

Removing the gas generator causes the transmitter to “pop-up” the Generator Removed Display (below), but *only if* the auto-test control is set to “READY”. Otherwise, the transmitter displays the generator review shown in **Error! Reference source not found.**, above, without causing a trouble alarm and pausing for the operator to disable Auto-test. The 4-20mA operates normally, and no operator intervention is required at the panel.



Figure 40. Generator Removed Display

At the conclusion of the Generator Removed Display (Exit selected or timeout), the transmitter displays the generator review shown in Figure 38, which pauses 5 minutes for the operator to select “Disable”. Selecting “Disable” forces the auto-test control to “OFF”, permanently, and prevents a trouble alarm. The auto-test control must be changed back to “READY” when a new generator is eventually installed. If “Disable” is not selected in time, the transmitter will activate the trouble alarm and continue to wait for “Disable” to be selected, or for a compatible generator or sensor to be installed (see on pg 45 for more details).

Generator Installed

When a generator is installed, and no problems are detected, the transmitter starts the generator review as depicted in Figure 38. If problems are detected, the transmitter starts the generator review as depicted in **Error! Reference source not found.**. The following table lists the types of problems that can occur with an installed gas generator.

Problem	Description
Wrong Gas Type	The generator is not compatible with the installed sensor.
Under-range	The generator cannot produce a gas concentration high enough for the currently programmed sensor range.
Read Error	The generator has an internal memory error.

4.5 Main Menu

Main Menu

The main menu provides direct access to the sensor calibration methods, data logger graph, and transmitter settings.

>Menu	Item	Select to ...
	Zero	Calibrate the gas sensor zero reading (see Sensor Zero Calibration page 42).
	Span	Calibrate the gas sensor sensitivity (see Sensor Span Calibration on page 43)
	Graph	View the contents of the logged data as a graph (see Data Log Graph on page 61).
	Setup	View and configure transmitter settings (below).

Figure 41. Main Menu

Alarm Active Menu

When a gas or trouble alarm is active, the following menu appears in place of the main menu.

>Menu	Item	Select to ...
	Alarm Status	View the Alarm Status Menu and clear manual reset alarms. This item appears only if a gas alarm is active (see Figure 69. Alarm S Menu on page 51).
	View Trouble	View the Trouble Status Display This item appears only if the trouble alarm is active (see Figure 73. Trouble Status Display on pg 53).
	Menu	View the Main Menu (above).

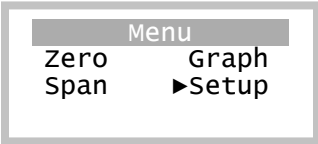
Figure 42. Alarm Active Menu

4.6 Setup Menu

>Menu>Setup	Item	Select to ...
	Sensor	Configure sensor settings, auto-test, and calibration methods (see 4.7 Sensor Menus, Methods, and Settings, on next page below
	Alarms	Configure the three gas alarms (see 4.8 Alarm Menus, Methods, and Settings on pg 49)
	Data log	View the data log graph (see 4.9 Data-log Menus, Methods, and Settings on pg 59).
	I/O	Configure the 4-20mA output, serial communications, and relay operation (see Error! Reference source not found. on pg Error Bookmark not defined.).
	Panel	Configure the display contrast and backlighting, and panel security (see on pg 70).
	System	Set the real-time-clock, site name, and view version information (see 4.12 System Menu on pg 77).

Figure 43. Setup Menu.

4.7 Sensor Menus, Methods, and Settings

Sensor Menu

>Menu >Setup >Sensor	<i>Item</i>	<i>Select to ...</i>
	Settings	Configure the sensor range, damping, and blanking (see Sensor Settings, below).
	Calibration	Maintain the accuracy of the gas sensor (see Sensor Calibration page 41)
	Auto-test	Configure automatic gas sensor tests or perform manual tests (see Sensor Auto-test on page 45).

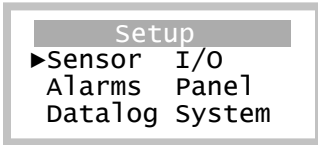
Figure 44. Sensor Menu.

Sensor Settings Menu

The transmitter accommodates a variety of sensors that automatically configure the transmitter with the gas name, range, units, and other settings, and contain calibration data to convert the sensor analog output to a gas concentration reading. Some of these settings can be changed by the transmitter and it is important to make sure they are configured properly for the site.

...Sensor>Settings	<i>Item</i>	<i>Description ...</i>
	Model	Displays the model name. Select to view sensor specific settings or information about the installed sensor (below).
	Gas	Displays the name of the target gas (read only).
	Range Menu	Select to view and adjust the sensor's upper range, blanking, and damping settings (below)

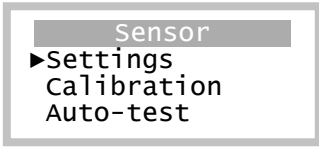
Figure 45. Sensor Settings Menu

Sensor Model Menu

...Settings>Model	<i>Item</i>	<i>Description ...</i>
	Line 1	Sensor model name (read only)
	Line 2	Sensor upper range limits (read only)

Figure 46. Sensor Model Menu

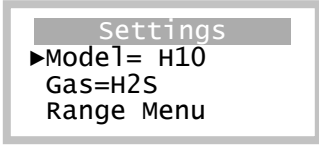
Sensor Range Menu

...Settings>Range Menu	Item	Select to ...							
	Range	Set the gas concentration value corresponding to the 20mA output value. Changing this value also changes the Blank (blanking) value, which is maintained as a fraction of the range. limits vary among sensors. Changing this setting invalidates data stored in the data logger (see below), and may result in an Auto-test exception message (also below).							
	Blank (Blanking)	Force the main reading to zero whenever the gas concentration is below this setting. The limits vary from sensor to sensor, but are typically 0 to 5% of Range. Note that the transmitter always reports negative readings as 0 (except on calibration displays) without regard to this setting. The setting is recomputed when the Range setting changes, so that the same fraction of range is maintained. Doubling, or halving the Range setting, doubles or halves the Blank ing setting, respectively.							
	Damp. (Damping)	Helps to stabilize the gas sensor readings. It is a unit-less value from 1 to 100 that controls a s/w lag filter. The setting has an approximate effect on the T90 ⁴ response time, as shown <table border="1" data-bbox="984 932 1295 1050"> <thead> <tr> <th>Damping</th> <th>T90 tim</th> </tr> </thead> <tbody> <tr> <td>1</td> <td>6 s</td> </tr> <tr> <td>10</td> <td>10 s</td> </tr> <tr> <td>100</td> <td>50 s</td> </tr> </tbody> </table>	Damping	T90 tim	1	6 s	10	10 s	100
Damping	T90 tim								
1	6 s								
10	10 s								
100	50 s								

Figure 47. Sensor Range Menu

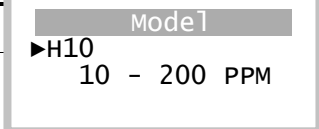
Effect of the Range Setting on the Data Logger

The data-logger records readings as a fraction of the sensor range. If data-logging is turned on (as indicated on the Main Display), changing the Range setting causes a warning message to appear prior to saving the value. Select “Save” to save the new Range setting, or “Abort” to leave it unchanged.

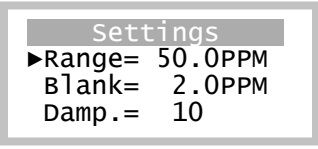
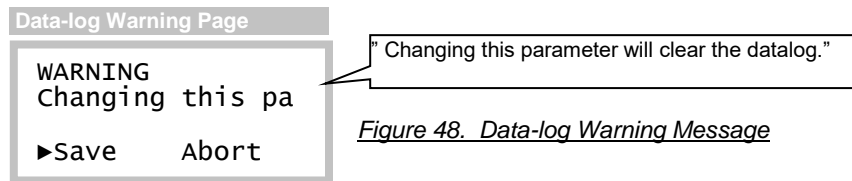

Figure 48. Data-log Warning Message

Effect of Range on Auto-test

Gas generators used for Auto-test may not be compatible on all sensor ranges. If the Auto-test Status is READY, scrolling to a higher Range may result in the following exception message, “Gas generator incompatible on sensor's range.” To overcome this exception, change the Auto-test Status to OFF, then set the desired range.

⁴ T90 is the approximate time required for the transmitter to reach 90% of its final value after a step change. The values given in the table do not include gas flow time or the actual response time of the sensor.

Sensor Calibration

Calibration Frequency

While the transmitter itself requires no periodic calibration, H10 sensors should be “zero” and “span” calibrated every 3-6 months, based upon environmental factors. Sensors frequently exposed to dirt, oil mist, vapors, or very dry air, may require more frequent calibration.

Zero Calibration

As the name implies, zero calibration corrects the transmitter offset reading in the absence of any reactive gas. During zero calibration, the offset error is stored in the sensor, and subsequently subtracted from future readings. ATI recommends bottled zero gas as a source, which should be selected based on the type of sensor. For example, bottled “Zero” Air may be used to zero Chlorine sensors, but Oxygen sensors require bottled Nitrogen gas.

Span Calibration

Span calibration corrects the transmitter sensitivity to a known concentration of target gas (the gas for which the sensor was designed to monitor). Sensors for most gases, such as Ammonia, require a bottled “span gas” source. This applies even to Oxygen sensors, where the span gas source is bottled zero air.

Calibration Terminology

The zero calibration is referred to as, “zero”, “zeroing”, and “zeroed”. Likewise for the span calibration, which appears as, “span”, “spanning”, and “spanned”. As with most instruments, zero calibration should be performed before span.

Calibration Kits

Calibration kits, containing zero and span bottle gas sources, are available from ATI for many toxic gases. Contact ATI, or your local ATI representative, if you have questions about calibration gas kits or gas sources.

Indications During Calibration

The “un-blanked” gas concentration value is displayed during zero and span calibration, primarily to observe any slight amount of positive or negative drift. Alarms are cleared and inhibited, and the 4-20mA output is locked at 4.0mA (transmitters equipped with Oxygen sensors are locked at 17.4mA, representing normal, 20.9% atmospheric Oxygen). The 4-20mA output will not change when gas is applied and removed, and for 15 minutes thereafter (the default value). While viewing the calibration pages, the LCD display will indicate the changing gas concentration.

Calibration Exceptions

Zero and span calibration are not allowed during the following conditions:

- ❖ Sensor removed, or in 5-minute⁵ warm-up period
- ❖ Trouble alarm active
- ❖ Auto-test active (status indicator appears on Main Display page)

To help prevent errors, zero and span are not allowed if the sensor output, or span value entered, is too high or too low. If detected, memory errors are reported while updating the sensor or transmitter memory.

⁵ Typical value, may vary by sensor gas type.

Sensor Calibration Menu

...Sensor>Calibration	Item	Select to ...
<div style="border: 1px solid black; padding: 5px;"> <p style="text-align: center;">Calibration</p> <p>►Zero History</p> <p>Span</p> <p>Temp= 21.1°C</p> </div>	Zero	Calibrate the gas sensor zero reading (below). Note – this item also appears in the Main Menu (see Figure 41. Main Menu)
	Span	Calibrate the gas sensor sensitivity (below). Note – this item also appears in the Main Menu (see Figure 41. Main Menu).
	Temp	Adjust the gas sensor’s temperature reading offset. Note: this reading may be slightly higher than ambient temperature due to self-heating. Contact the factory before adjusting.
	History	View the transmitter calibration records.

Figure 49. Sensor Calibration Menu

Sensor Zero Calibration

Performing a zero calibration requires a bottled “Zero-gas” with a 500 cc/min regulator, calibration adapter, and a convenient length of ¼” tubing. The gas used depends on the type of sensor installed. For example, an H₂S sensor may be zeroed with Zero-air, however, Oxygen sensors must be zeroed with Nitrogen. In some cases, a sensor may be zeroed directly to the atmosphere, but only when it is known to be free of reactive gasses. Check with the factory if you are uncertain about which gas to use.

Referring to Figure 50, push the calibration adapter onto the exposed end of the sensor and connect one end of the tubing (1), connect the other end of tubing to the cylinder’s regulator (2). Do not open the gas valve until instructed below.

Select the Zero method from the Sensor Calibration menu, as shown in Figure 51⁶. This will clear and inhibit alarms at the transmitter, and hold the current loop output at 4mA (17.4mA for Oxygen sensors) for up to 30 minutes of no key activity.

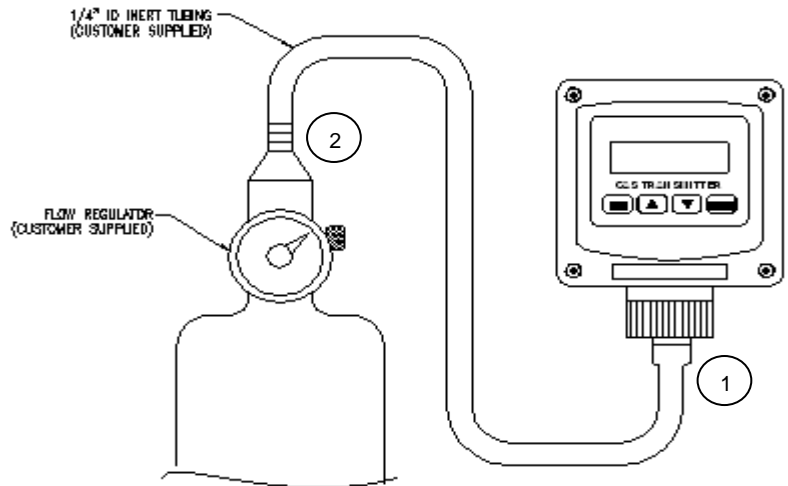

Figure 50. Sensor Zero Cal. Setup

...Sensor>Calibration	...Calibratio
<div style="border: 1px solid black; padding: 5px;"> <p style="text-align: center;">Calibration</p> <p>►Zero History</p> <p>Span</p> <p>Temp= 21.1°C</p> </div>	<div style="border: 1px solid black; padding: 5px;"> <p style="text-align: center; font-size: 2em;">0.0</p> <p style="text-align: center;">PPM H₂S</p> <p>►Zero Cal</p> </div>

Figure 51. Sensor Zero Cal. Menus

Open the regulator to flow gas to the sensor. After approximately four minutes, select Zero. “Cal” will appear briefly at the bottom of the page and the reading will be forced to 0, 0.0, or 0.00. Since the reading is not blanked, it may show a negative sign, like “-0.0”, which is normal. Press the Esc key twice to return to the Main page. Alarms will remain inhibited, and the current loop will be fixed for 30 minutes after calibration.

⁶ The zero method is also directly accessible from the main menu.

Sensor Span Calibration

Span calibration* requires a bottled “span-gas” with a 500 cc/min regulator, calibration adapter, and a convenient length of ¼” tubing. The gas type and concentration used depends on the type of sensor installed. Check with the factory if you are uncertain about which gas to use.

Referring to Figure 52, slip the calibration adapter onto the exposed end of the sensor and connect one end of the tubing (1), connect the other end of tubing to the cylinder’s regulator (2). Do not open the gas valve until instructed below.

* Perform the Zero calibration prior to the Span calibration.

Select the Span method from the Sensor Calibration menu, as shown in Figure 52⁷. This will clear and inhibit alarms at the transmitter, and hold the current loop output at 4mA (17.4mA for Oxygen sensors) for up to 30 minutes of no key activity.

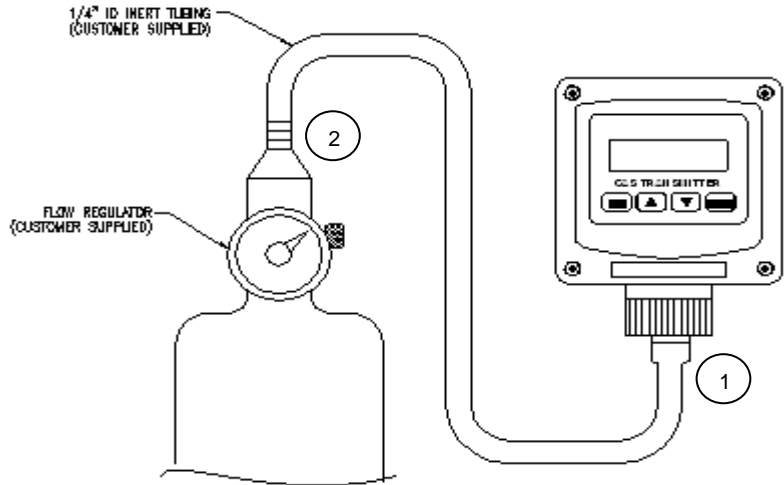
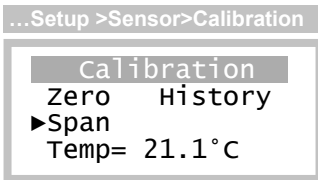
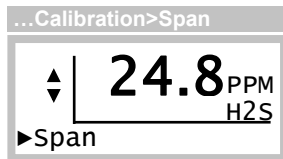

Figure 52 Sensor Span Cal. Setup



Open the regulator and allow gas to flow to the sensor. The displayed reading should begin to increase and stabilize after 5 to 10 minutes, depending on the gas type and range of the sensor.



Select Span, the concentration reading will become fixed, and the blinking Up/Dn edit cursor will appear just to the left of the reading. Press the **Up** or **Down** key to correct the reading to match the known concentration of gas.

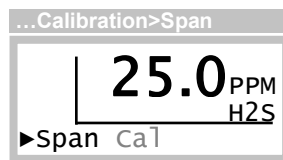

Press the **Enter** key to perform the calibration. “Cal” will appear briefly at the bottom of the page.

Figure 53. Sensor Span Cal. Menus

Press the **Esc** key twice to return to the Main page. Disconnect the calibration adapter from the sensor and permit the readings to return to zero. Alarms will remain inhibited and the current loop will be fixed for 30 minutes after calibration. Once the reading is below any of the alarm set levels, you may terminate the alarm inhibit (and fixed loop output) using the **Esc** key on the Main Display, see Inhibiting Alarms from the Main Display on page 36.

⁷ The span method is also directly accessible from the main menu.

Sensor Calibration History

A calibration record is written into the sensor memory each time a zero or span calibration is performed. Enough memory is reserved for 63 zero calibrations and 63 span calibrations. Zero and span calibration records are accessed on the Sensor Calibration History page.

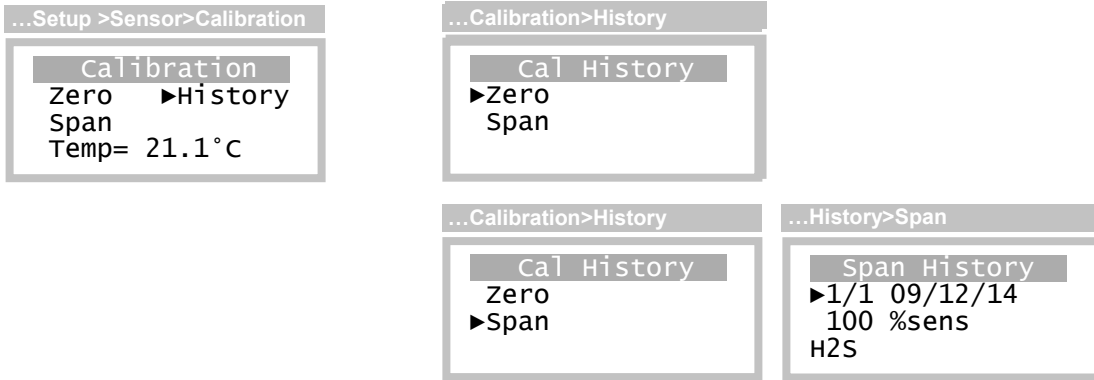

Figure 54. Sensor Calibration History Menus

Zero calibration records are composed of an index field (record no/total records), date, concentration reading, and gas name. The reading is recorded just before applying the correction, and can be thought of as “drift” from the previous zero calibration. Upon entry, the index number is set to the most recent calibration and may be scrolled down to view earlier calibration records.

Span calibration records are composed of an index field, date, and the relative sensitivity of the sensor. Like the zero records, the index number is set to index the most recent calibration and may be scrolled down to view earlier calibration records. Span calibrations record the deviation from the reference sensitivity and display it in units of percent. Sensitivity is a measure of the sensor output for a given exposure to gas. More specifically, it is defined as the ratio of the signal output to the gas concentration and is often measured in $\mu\text{A}/\text{PPM}$. During manufacture, the sensitivity of the sensor is recorded and used as a reference. A value of 100% signifies that the sensitivity has not changed from the reference e.g., the sensor calibration is the same at it was when the sensor was calibrated at the factory. Lower values indicate a decreased sensitivity and, although not typical, higher values indicate increased sensitivity. When the sensitivity drops to 10% it is time to replace the sensor.

Sensor Auto-test

Auto-test verifies the serviceability of the sensor on a prescribed schedule by exposing it to a small amount of gas, and verifying a minimum response. Three attempts per test are made, and if the sensor does not respond on the third attempt, a temporary trouble alarm is triggered (may be optionally disabled). A summary of pass, fail, and retry counts are maintained in the sensor memory, and may be viewed on the Auto-test History page.

The test is performed at a specific time of day, and may be scheduled to repeat every 1 to 14 days. The date and time of the next test is available for editing, and the test may be triggered manually at any time, without affecting the preset schedule.

The Auto-test option requires an optional gas generator that is compatible with the installed sensor’s gas type and full-scale range. For more information, see Table 7. H10 sensor modules and Table 8. E18 gas generators.

Auto-test Menu

...Sensor>Auto-test	Item	Select to ...
	Status	Change the Auto-test state:
		OFF – Auto-test will not start automatically.
		READY – Updates NextAT and arms Auto-test to start automatically on a scheduled basis. The transmitter will not permit this selection if a compatible gas generator is not installed.
		START – Runs Auto-test once and returns to the original state. Does not affect the date of the next Auto-test (see NextAT below). transmitter may not always permit this selection (see below).
		STOP – Ends an Auto-test in progress, updates NextAt, and returns to READY or OFF
		When Status= Start, a test will occur upon return to the Main Display, either manually by pressing Esc , or after a Timer Return on Display (see pg 36).
		If Auto-test is already in progress, selecting Status presents the Auto-test Status display (see Figure 62. Auto-test Status Display Sequence on page 48).
	Setup	Configure the interval, pass value, and options (below).
	GasGen	View the gas generator information.
	History	View the pass, fail, and retry counts of previous Auto-test attempts.
	NextAT	View and change the date and time of the next Auto-test.

Figure 55. Auto-test Menu

Conditions Preventing Selection of Ready or Start

You may not set Status to READY or START if a generator is not installed, has a fault, or is not compatible with the sensor gas type or range. Furthermore, Auto-test will not START when an alarm or transmitter fault is detected, or any other conditions described in on page 47 are present. When attempted, the transmitter displays an exception message.

Auto-test Setup Menu

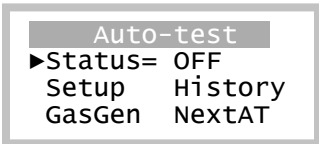
...Auto-test>Setup	Item	Select to ...
	Day Interval	Configure the number of days between automatic tests. The default is 1, and the limit is 1 to 14 (the exact time of day for testing may be set on the Next AT menu, see below).
	Pass	Configure the amount by which the gas concentration must increase, in order to pass. Prior to starting the test, this amount is added to the “un-blanked” gas concentration reading to compute the pass value. This value is limited between 5%(default value), and 10% of the sensor range (see Range in Sensor Setting Menu on pg 39).
	Options	View the Auto-test Options page (below).

Figure 56. Auto-test Setup Menu

Auto-test Setup Options Menu

...Auto-test>Setup>Options	Item	Select to ...
	Logging	Control values logged during Auto-test. When set to Yes (default), concentration (main reading) is logged as usual, including any increase caused by the gas generator. When set to No, a code is logged that will display as, TEST, on graphic and tabular report pages, and printouts.
	Trouble	Determine if Auto-test failures cause trouble alarms. When set to YES (default), a failure to pass Auto-test after the third attempt will cause a trouble alarm, and force the 4-20mA output to the Trouble mA value. When set to No, Auto-test failures do not cause Trouble alarms (not recommended).
	Fixed mA	Control the 4-20mA output during Auto-test. When set to Yes (default), the 4-20mA output will be fixed at the Autotst mA value to prevent receiver alarms (see Figure 87. 4-20mA Menu). set to No, the output will increase as the gas concentration rises, and may cause receiver alarms (not recommended).

Figure 57. Auto-test Setup Options Menu

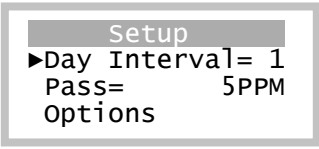
Auto-test NextAT Menu

...Auto-test>NextAT	
	The date and time of the next auto-test appears on the Next AT menu. After each test, the date is incremented by the Day Interval setting on the Auto-test Setup page (above). The time establishes the time of day that tests are performed. Setting Auto-test to occur in the past when the Status is READY will change the Status to START.

Figure 58. Auto-test Next AT Menu

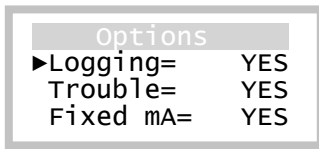
NextAT Date After Startup

During startup, the transmitter examines the date of the next auto-test and advances it by the Day Interval to provide a minimum of 24 hours before the next test is performed. Therefore, it is important to keep the transmitter powered to maintain the desired test Auto-test schedule.

Auto-test History Menu

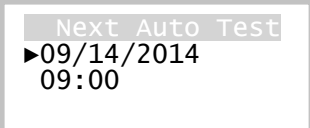
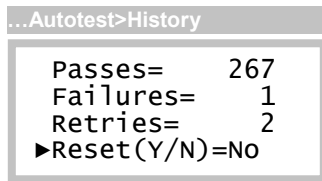

The Auto-test History Menu provides a summary of passes, failures, and retries, which are maintained in the sensor memory. Three attempts are made before a failure is recorded. The total number of tests is the sum of the passes and failures, and the number of gas generations is the sum of all three counts. Setting Reset to “Yes” clears all counts to zero, which is not normally recommended.

Figure 59. Auto-test History Menu

Gas Generator Display

▶Menu>Setup>Auto-T>GasGen		Item	Select to ...
<pre> Gas Generator 100 PPM H2S 0.07 mAH Used 5 PPM/1.00mA </pre>	(Line 2)	Name of gas generated and maximum (compatible) sensor range.	
	(Line 3)	Generator use in units of mAH (milliamp-hours)	
	(Line 4)	Change in concentration required to pass Auto-test (same as Pass in Figure 56), and current applied to generator (or if problem detected: Wrong Gas Type, Under-range)	

Figure 60. Gas Generator Display

Auto-test Exceptions

Auto-test will not start if any of the following conditions are present. Furthermore, Auto-test is immediately aborted when any of the critical exceptions are detected.

Non-critical Exceptions

- The sensor is warming up (animated hour glass visible on main display).
- The gas concentration is greater than 10% of the sensor range.
- Auto-test has already been started (manually).

Critical Exceptions

- Gas generator is missing, or is not compatible with the sensor type or range.
- Gas alarm is active or being tested.
- The trouble alarm is active or a fault is detected.

Auto-test Status Display

Auto-Test Status Display		Item	Select to ...
<pre> Auto-test ▶GENERATE 05:00 Reading= 0PPM PassVal= 5PPM </pre>	(Line 1)	Change the Auto-test state to STOP, READY, OFF (see Status in Figure 55 on pg 45)	

Figure 61. Auto-test Status Display

When Auto-test starts, the Auto-test Status Display Sequence appears. This happens automatically from the Main Display (pg 35), or by setting Status= START on the Auto-test Menu (see pg 45). Figure 62, below, illustrates the appearance of the Auto-test Status Display Sequence as Auto-test sequences. During Auto-test, alarms are inhibited, and the 4-20mA output is fixed (usually at 4mA, however, see Auto-test Setup Options Menu and Figure 87. 4-20mA Menu). This condition continues for up to 10 minutes after the gas-generation ends, during the recovery period. If a significant gas leak occurs during this time (50% or more of the sensor range), Auto-test is aborted, alarm inhibit is cleared, and the 4-20mA operation reverts to normal.

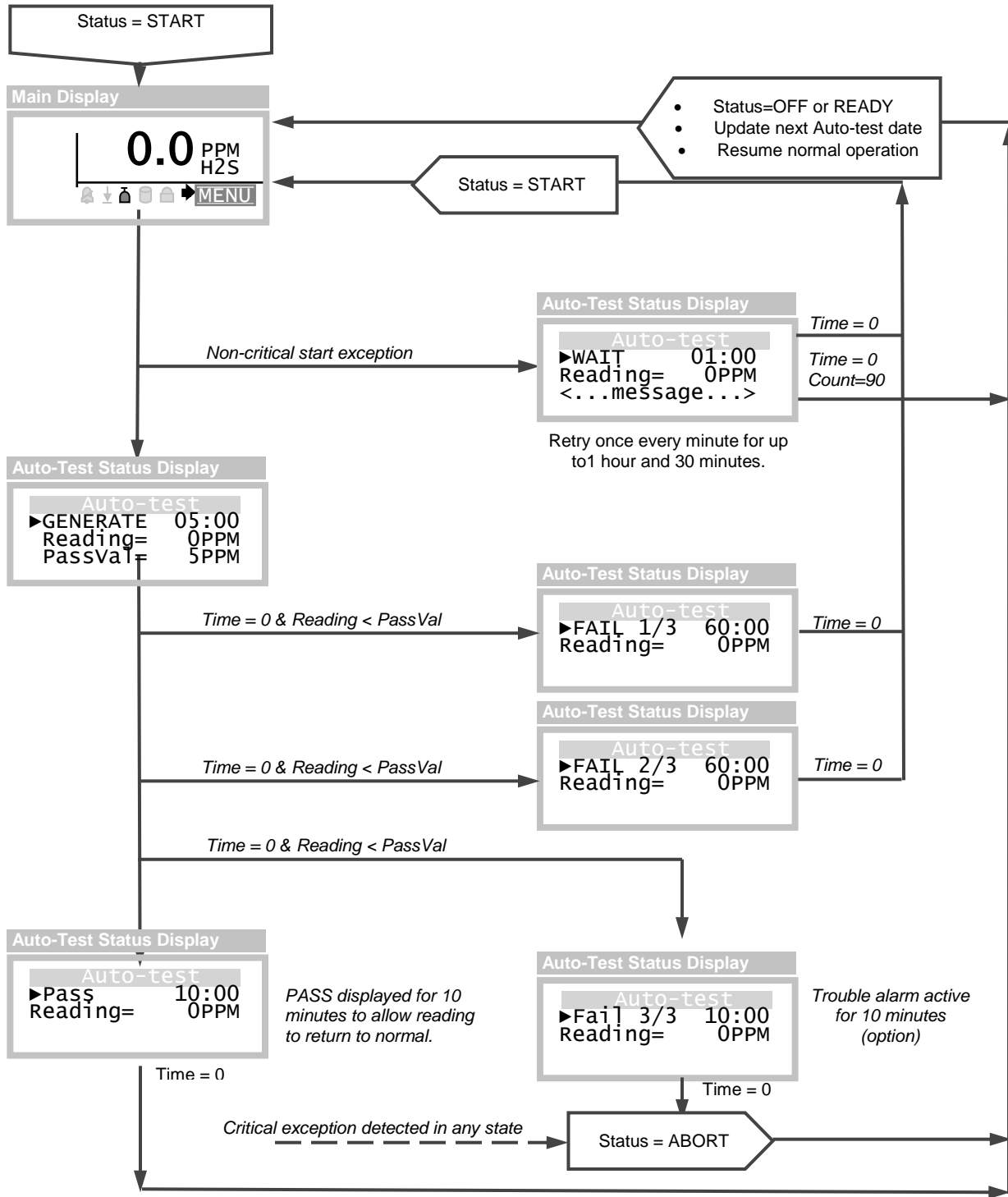

Figure 62. Auto-test Status Display Sequence

4.8 Alarm Menus, Methods, and Settings

The transmitter features three gas level alarms - Alarm, Warning, and Caution, and a Trouble alarm. Gas level alarms are automatically configured when a gas sensor is installed, and are retained between same type sensors. Alarm status appears on the Main Display, is available over the optional serial interface, and is used to activate the three optional relays (see Relay Operation, Menus, and Settings on page 70).

Alarms Menu

The Alarms Menu is the main entry point for configuring gas level alarms, and for inhibiting and testing configured alarms.

Menu>Setup>Alarms	Item	Select to ...
	Alarm	Configure the Alarm settings to indicate a dangerous condition (see Alarm Setting Menus on pg 52).
	Warning	Configure the Warning settings to indicate an unsafe condition (see Alarm Setting Menus on pg 52).
	Caution	Configure the Caution settings (normally used to indicate excessive sensor drift - see Alarm Setting Menus on pg 52).
	Inhibit	Configure or activate the manual alarm inhibit period (see Alarm Inhibit on pg 57)
	Test	<u>Test operation of the alarm indicators and relays (see Alarm Test Menu on pg 58)</u>

Figure 63. Alarms Menu

Gas Level Alarms

For toxic gas sensors, Alarm is a high-high alarm and the default setting for Alarm is normally 2 or 3 times higher than the TLV (threshold limit value) of the target gas. The Warning alarm is a high alarm and normally set to the TLV. Caution is a low alarm and set to activate on negative drift of -10% of the sensor range (a trouble alarm occurs if the reading drifts to -20% of the sensor range). Figure 64 depicts the relationships of these alarms.

Figure 64. Toxic Gas Alarms.

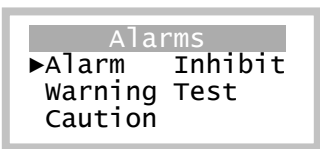
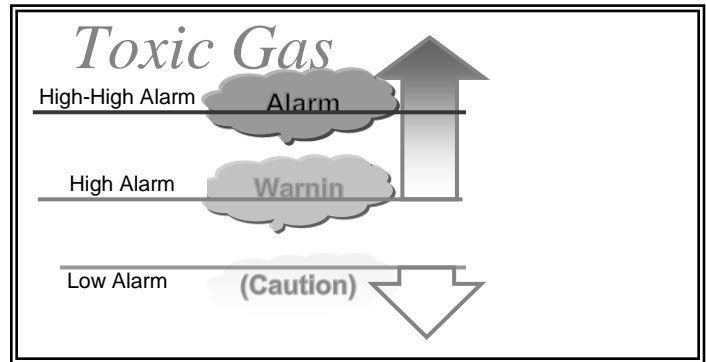

For oxygen sensors, Alarm is a low-low alarm set to 16%, Warning is a low alarm set to 19.5%, and Caution is a high alarm set to 23%.

Figure 65 depicts the relationships of these alarms.

Figure 65. Oxygen Deficiency Alarms

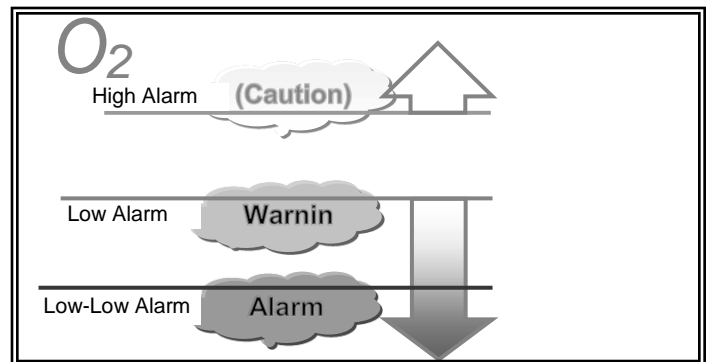

Gas Alarm Operation

Figure 66 illustrates the operation of a high (rising) gas level alarm.

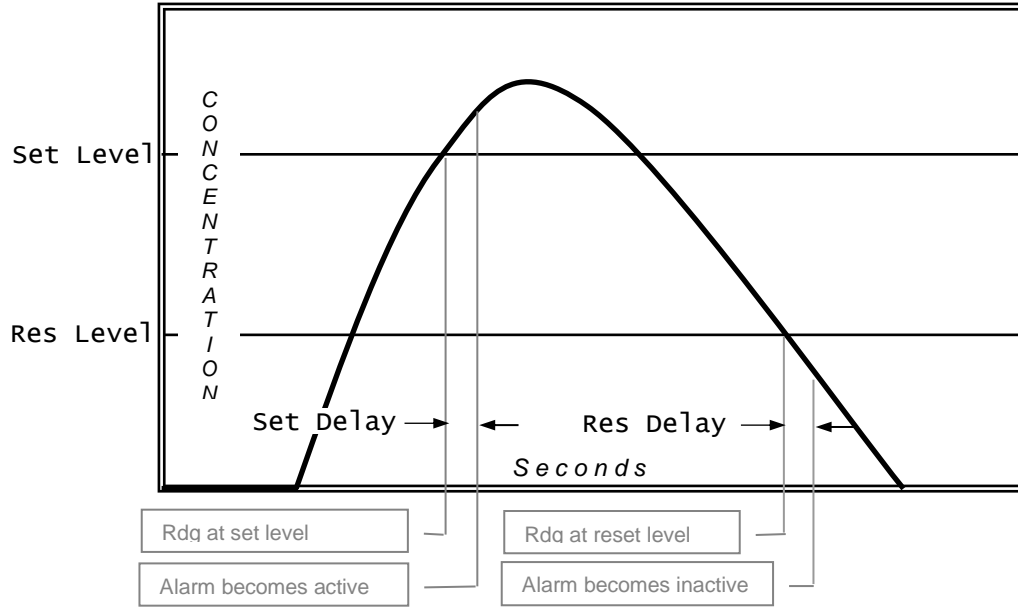

Figure 66. High Alarm Operation

Figure 67 illustrates the operation of a low (falling) gas level alarm (such as for Oxygen deficiency).

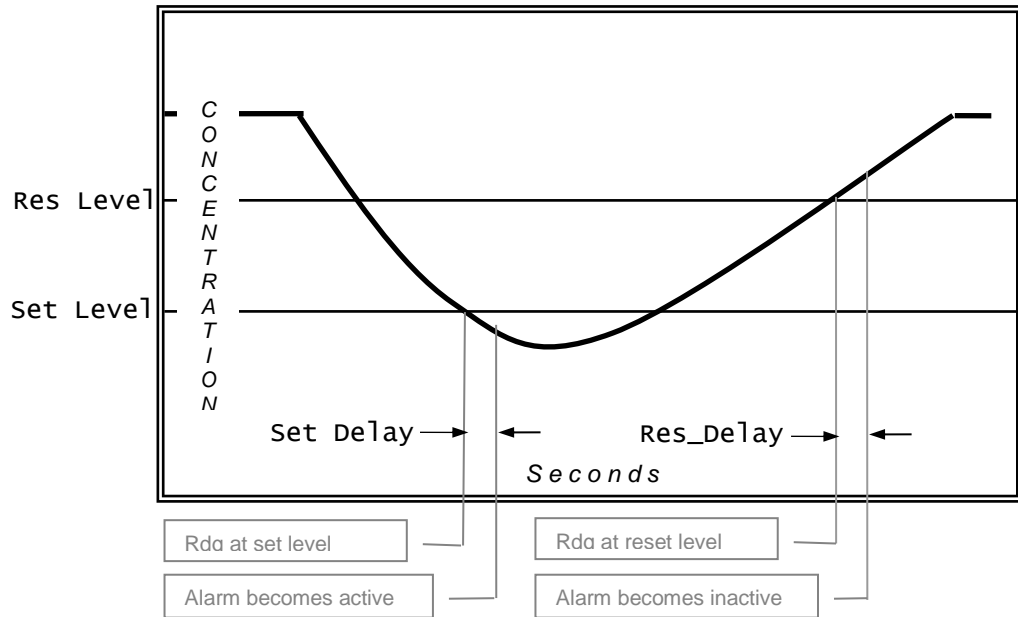

Figure 67. Low Alarm Operation

Alarm Indicators

Gas level alarms are indicated by three flags on the left side of the Main Display, each containing a letter indicating the alarm name, and an arrow indicating the type of alarm - high (rising) alarm, or low (falling) alarm.

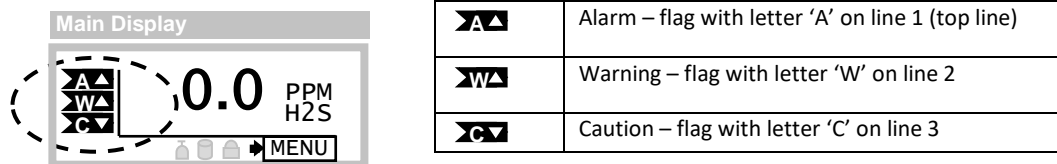

Figure 68. Alarm Indicator Flags

Alarm Status Menu

The Alarm Status Menu appears only when a gas alarm is active. It is displayed by selecting Menu from the Main Display, then selecting “Alarm Status”, from the Alarm Active Menu (see pg 38). The menu lists the three gas alarms and the word, “Active”, if the alarm is currently active. Selecting an active alarm displays the specific Alarm Reset Menu, below.

...Alarm Status>(alarm)	Item	Select to ...
09/26/06 18:11 ▶Reset ALARM Reset All Inhibit_Alarms	(line 1)	Date and time of alarm event.
	Reset (alarm)	Manually reset the alarm selected on the Alarm Status Menu above. Reset is performed only if the alarm conditions have subsided, and the alarm is programmed for manual reset (see Figure 71. Alarm Settings pg 52),
	Reset All	Manually reset all manual-reset alarms, once alarm conditions have subsided.
	Inhibit Alarms	Temporarily resets and inhibits gas level and Trouble alarms (is 15 minutes, see Alarm Inhibit on pg 57).

default

Figure 69. Alarm Status Menu

Alarm Reset Menu

The Alarm Reset Menu appears by selecting an active alarm from the Alarm Status Menu, or by selecting an alarm indicator flag from the Main Display. The menu presents the date and time of when the alarm became active, and permits manual reset, along with the other options are listed below.

Menu>Alarm Status	Item	Select to ...
Alarm Status ▶Alarm Active warning Active Caution	Alarm	View the time and date of Alarm and manually reset it, if required.
	warning	View the time and date of the Warning alarm and manually reset it, if required.
	Caution	View the time and date of the Caution alarm and manually reset it, if required.

Figure 70. Alarm Reset Menu

Remote Reset

Activating the “Remote Reset” input resets all manual reset alarms, but only if the respective alarm conditions have subsided (see Figure 23 – Remote Reset Input on page 24).

Alarm Setting Menus

The Alarm Setting Menus are accessed from the Alarms Menu and are used to configure the three gas level alarms.

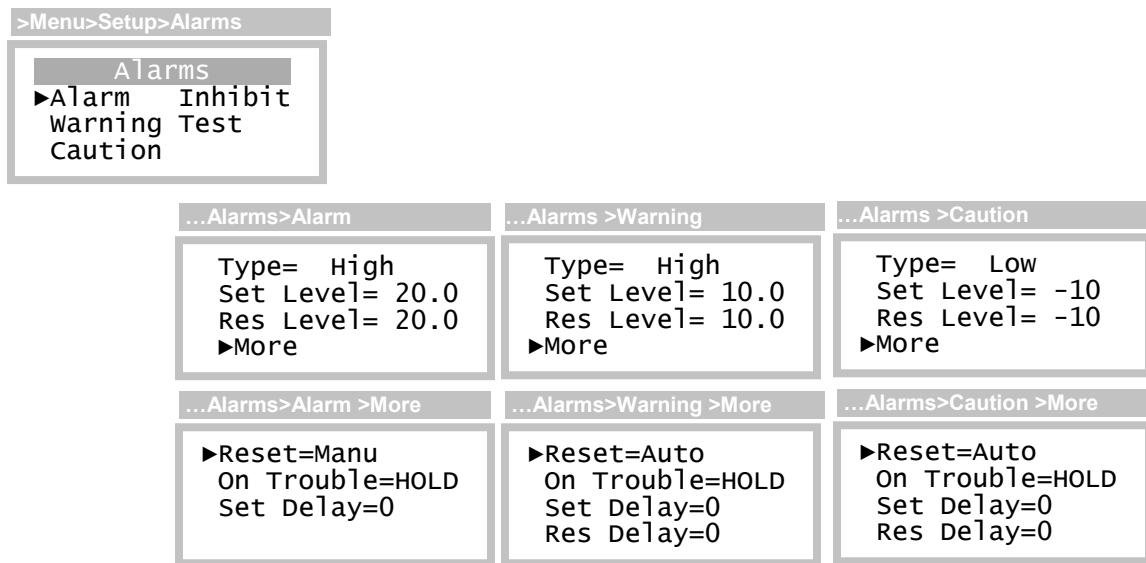

Figure 71. Alarm Setting Menus

Item	Select to...
Type	Set the type of alarm as High, Low, or None. When set to High, the alarm becomes active <i>at and above</i> the Set Level. When set to Low, the alarm becomes active <i>at and below</i> the Set Level. Setting the value to None permanently deactivates the alarm. The setting is stored in the sensor memory.
Set Level	Set the gas concentration level at which the alarm becomes active. The alarm then becomes active at the expiration of the Set Delay period. Changing Set Level changes Res Level to the same value. Limits for the Set Level are maintained in the gas sensor memory.
Res Level	Set the gas concentration level at which the alarm becomes inactive. The alarm then becomes inactive after expiration of the Res Delay period, and only if the Reset setting is programmed as Auto – see below. The limits for the Res Level depend on the alarm Type setting. Type = High Upper limit = Set Level Lower limit = lowest Set Level Type = Low Upper limit = highest Set Level Lower limit = Set Level Changing Set Level changes Res Level to the same value.

<p>Reset</p>	<p>Select how the alarm is reset as Manu or Auto. When set to Auto, the alarm will Reset (clear) without operator intervention, as soon as conditions allow (concentration reaches Res Level, and the Res Delay period expires). When set to Manu, the operator must reset the alarm manually after conditions subside, through the operator interface, the serial interface, or through the remote reset (see Figure 23 on page 24).</p> <p>Note: Res Delay is meaningful only when Reset= Auto. Setting Reset to Manu suppresses display of the Res Delay setting.</p>
<p>On Trouble</p>	<p>Specify the alarm state during Trouble alarms. This setting specifies alarm behavior during transmitter faults, and overrides all other alarm settings. If the trouble alarm should become active, you may program the concentration alarm to behave in one of three ways: Hold - the transmitter will attempt to hold the alarm in its current state. If the alarm is active, it will remain active. If the alarm is inactive, it will be inhibited from becoming active until after Trouble is cleared. Set - activates the alarm immediately (the Set Delay period is ignored). This feature permits the alarm to signal both concentration and trouble conditions. Reset - deactivates the alarm immediately (the Res Delay period is ignored).</p>
<p>Set Delay</p>	<p>Configure the amount of time, in seconds, that the gas concentration must be at or above a high alarm set level, or at or below a low alarm set level, before the alarm becomes active. This is used to avoid triggering alarms on relatively short gas exposures. The setting may be programmed between 0 (its default) and 10 seconds.</p>
<p>Res Delay</p>	<p>Configure the amount of time, in seconds, that the gas concentration must be below high alarm reset level, or above a low alarm reset level, before the alarm becomes inactive. The setting is typically used to keep relays energized to maintain exhaust fans after a gas leak. The setting is displayed only when Reset is set to Auto, and may be programmed between 0 (default) and two hours (7200 seconds).</p>

Trouble Alarm

Trouble alarm are presented on the Main Display as shown below. When active, new alarms are inhibited, and (by default) active alarms are held so that relays controlling lights, sirens, and fans may continue to operate (this behavior may be modified on the Alarms Menu (see pg 49). Certain Trouble alarm causes, like a temporary bus fault, may clear automatically without operator intervention. Others, such as a missing sensor, will not clear until corrected.

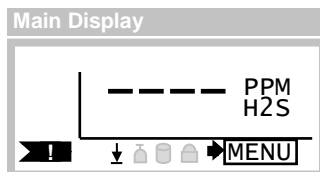
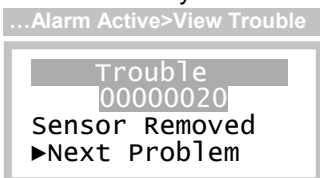

Figure 72. Trouble Indication on Main Display

Trouble Status Display

The Trouble Status Display appears by selecting the Trouble indicator from the Main Display. It may also be viewed by selecting MENU from the Main Display when the Trouble alarm is active, then selecting view Trouble. The 8-digit hex code on line 2 represents all active faults and is useful when obtaining help from the factory. Select Next Problem to view a description of each problem in succession on line 3.



Some problems listed in Table 2 (on page 55) are cleared after pressing Esc to return to the previous display.

Figure 73. Trouble Status Display

Corrective Actions

Prior to opening the transmitter housing:

- **Declassify the hazardous area** - if the transmitter is located in a hazardous location.
- Check connections and wiring outside of the transmitter for shorts or opens.
- Unplug the sensor and generator modules and inspect the connectors for bent or recessed contacts.

After the transmitter housing is open:

- Start by checking connections inside the housings in the order listed under “Corrective Actions”.
- If none of the listed corrective actions solve the problem, replace the transmitter board electronics.

After replacing the sensor, generator, or SIB board:

- Review, verify, and restore all Sensor and Auto-test settings. This includes the critical sensor settings like range and blank, and the Auto-test Status setting (status must set to READY for automatic operation).

After replacing the CPU board:

- Review, verify, and restore all transmitter settings.

General Trouble

The table below lists troubles for which no message is displayed.

Table 1. General Trouble

Problem	Corrective Action
Transmitter won't start.	<ol style="list-style-type: none"> 1 At power on, transmitters powered in 3-wire or 4-wire mode demand 2 times the normal amount of supply current. If the supply is not sized properly, transmitters may not power on, or may produce a fault in the external power supply. If this is suspected, try starting transmitters one at a time. 2 Check that each transmitter has at least 12VDC between pins 5(+) and 6(-) of TB1 on its Power Supply board. This is more easily done using <u>temporary</u> lead wires from the connector.
Gas reading unstable, drifting.	<p>Ground loops are a common cause of unstable readings, and may represent a dangerous condition. A ground loop occurs most often when a drain wire, cable shield, DC supply (-), <u>or any other wire</u> makes contact to two or more transmitter housings, remote sensor housings, receivers, power supplies, or metal cable conduits. Metal housings must be bonded to earth ground for safety, and any difference in earth potential between the two points will cause current to flow in the wire or shield. This current might then cause errors in the transmitter's high-gain analog input, or possibly exceed the rating of the conductor.</p>

Trouble Messages

Table 2 describes the trouble messages and lists the corrective action codes, which are listed below.

Table 2. Trouble Messages

Trouble	Description	Corrective Action(s)
Gas Signal Err	The analog-to-digital converter channel assigned to the sensor’s gas concentration output signal has failed, or is out of range.	1-3,4,6,8
LCD Busy Error	The LCD driver chip cannot recover from an internal error.	1-3,9,7,8
SPI/I2C Bus Error	An internal CPU bus has faulted.	1-3,7,9
Tmp. Signal Err	The analog-to-digital converter channel assigned to the sensor’s temperature output signal has failed, or is out of range.	1-3,4,6,8
Sensor (-)Range	The sensor has drifted -20% range (below zero).	See Table 1 Zero calibrate the sensor 4,6,8
Sensor Removed	The sensor cannot be detected.	2-4,6,8
Sensor NVM Err	One or more configuration settings in the sensor memory do not pass checksum test.	4,6,8
Sensor Config	One or more sensor configuration settings are outside of their expected range.	4
Generator NVM	The generator’s non-volatile memory is corrupt.	5,6,8
Auto-test Fail With Gen. Config Err	Auto-test is enabled (Status=READY) and a problem has been detected with the gas generator, or the gas generator is not compatible with the sensor’s type or range. This problem is reported on the display during startup, when a sensor is installed, and when a generator is removed or installed.	4,5, or disable Auto-test (set Status to OFF)
NVM1 User CRC	An error has been detected in the user settings stored in the transmitter’s primary non-volatile memory.	2,3, otherwise, reset the user memory defaults (see Reset Menu on pg 77) If the problem persists, replace the CPU board.
NVM1 Fact CRC	An error has been detected in the factory settings stored in the transmitter’s primary non-volatile memory.	2,3,7
NVM2 User CRC	An error has been detected in the transmitter’s secondary non-volatile memory.	Not applicable on this transmitter
NVM2 Fact CRC	An error has been detected in the transmitter’s secondary non-volatile memory.	Not applicable on this transmitter
Auto-test Fail Without Gen. Config Err	Auto-test failed after three attempts (and the Auto-test Trouble is set to YES).	5,4,6

3W Pwr Required	Relays or RS232/485 communication is enabled, but transmitter does not have 3-wire power applied.	If relays are not being used, disable them (see Relays Menu on pg 71)
Xmtr Uncal	The transmitter’s factory calibration data has become corrupted.	2,3,7
CPU Trouble	A stack overflow or other internal error occurred in the CPU.	2,3,7
Fault Test	Trouble alarm is being tested, not a real fault.	
Gas Sensor Uncal	The gas sensor appears to be uncalibrated, which occurs after resetting its memory.	Zero and Span calibrate the sensor.
No User Verify	A setting was not verified I within 5 minutes.	Restart transmitter (2) and verify settings.
Hardware Fault	The real-time-clock, a memory chip, or some other component has failed or been corrupted. The transmitter will restart upon exit from the Trouble Status Display (pg 53), or automatically from the Main Display after 5 minutes.	1,3,7,8
Sensor COM TmOut	The SIB is not responding.	2,3,6,7,8
Sensor COM Error	The SIB is responding with physical communication errors.	2,3,6,7,8
Sensor Proto Err	The SIB is responding with protocol errors (ie, bad crc). This could be caused by physical communication errors.	2,3,6,7,8
Sensor Reply Err	The SIB is responding with bad information.	2,3,6,7,8
Sensor CPU Trble	The SIB is reporting a stack overflow or other internal error occurred in its CPU.	2,3,6,7,8
Sensor H/W Error	The SIB is reporting a non-volatile memory or other hardware component has faulted.	2,3,6,7,8
Sensor NVM1 CRC	The SIB is reporting an error has been detected in the user or factory settings stored in its primary non-volatile memory.	2,3,6,7,8
Sensor NVM2 CRC	The SIB is reporting an error has been detected in the user or factory settings stored in its secondary non-volatile memory.	Not applicable on this transmitter.

Corrective Action Codes

1. Select View Trouble (status is cleared on exit, see Trouble Status Display on page 53)
2. Restart the transmitter (Menu>Setup>System>Reset>Restart)
3. Toggle power off and on
4. Replace the sensor
5. Replace the generator
6. Replace the SIB
7. Replace the CPU Board
8. Replace the Power Supply Board
9. Replace the Display Board

Alarm Inhibit

Alarms are inhibited to temporarily disable (false) activation and should be re-enabled as soon as possible to maximize the safety of the area. The duration of inhibit period depends the method used to activate it. For example, alarm inhibit occurs automatically during zero and span calibration and expires after 30 minutes. The table below summarizes the duration of the alarm inhibit periods for each method used to initiate it.

Table 3. Alarm Inhibit Periods

<i>Method</i>	<i>Alarm Inhibit Period</i>
Start up	(same as Sensor Install below)
Zero,Span	Set immediately on entering the method Then for up to 30 minutes after pressing a key while in the method
Sensor Auto-test	5 minutes during gas generation attempt 10 minutes during recovery period
Sensor Removal	60 seconds, then Trouble alarm active
Sensor Install	Alarm inhibit active during sensor warm-up (usually 5 minutes)
Manual activation from Main Display using Esc key	Duration value in Alarm Inhibit Menu
Manual activation by Start in Alarm Inhibit menu	Duration value in Alarm Inhibit Menu

The Main Display indicates when alarms are inhibited (see Status Indicators in Figure 37 on page 35), and the 4-20mA output is fixed at the Inhibit mA (see below).

The most convenient method for manually starting alarm inhibit is from the Main Display. For more information on that method, see Inhibiting Alarms from the Main Display on page 36. Alarm inhibit may also be started through the Alarm Inhibit Menu, shown below.

Alarm Inhibit Menu

The Alarm Inhibit Menu exposes the manual alarm inhibit start and stop control, and the duration and fixed 4-20mA setting.

>Menu >Setup >Alarms >Inhibit	<i>Item</i>	<i>Select to ...</i>
	Inhibit_mA	Set the fixed value of the 4-20mA output during alarm inhibit (3.5 to 22.0 mA). This is normally 4mA for toxic gas sensors, and 17.4mA for oxygen sensors.
	Duration	When alarm inhibit is off : Set the manual alarm inhibit period (0-60, default=15 minutes). When alarm inhibit is on : Adjust the amount of time remaining.
	Start (Stop)	Start (or stop) alarm inhibit

Figure 74. Alarm Inhibit Menu



Alarm Test Menu

The Alarm Test Menu can be used to test the gas level and Trouble alarms to verify operation of the associated relays (see Relay Operation, Menus, and Settings on page 70).

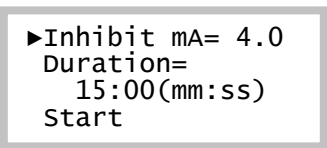
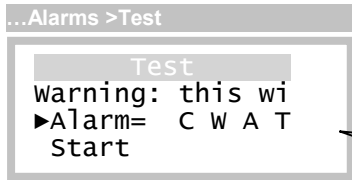
“This will activate alarm relays”



Note

Devices wired to the relays may activate when “Start” is selected. Inform all personnel before performing the test.

<i>Display</i>	<i>Instructions</i>
	Select Alarm
	Scroll up or down to specify which alarms to test - C, W, A, T, and save the selection by pressing the Enter key. (C=Caution, W=Warning, A=Alarm, T=Trouble)
	Select Start to begin the test.
	Press any key to end the test. The test stops automatically after 5 minutes.

Figure 75. Alarm Test Menu

4.9 Data-log Menus, Methods, and Settings

The transmitter records gas concentrations in one of 12 intervals ranging from 1 to 60 minutes, providing data from 11 to 474 days. Table 4 details the sampling intervals, and the samples/day and totals days for each interval.

Table 4. Data-log sampling metrics

Sampling (Minutes)	Samples/Day	Total Days
1	1440	11
2	720	22
3	480	32
4	360	43
5	288	54
6	240	64
10	144	104
12	120	124
15	96	152
20	72	196
30	48	278
60	24	474

The gas concentration reading is recorded as an instantaneous value and is not averaged or filtered in any way. When the data log memory is filled, new records overwrite older ones.

Data Log Menu

The Data Log Menu permits access to configuration, review, and print menus.

>Menu >Setup >DataLog	Item	Select to ...
	Setup	Configure the data log settings (see Data Log Setup Menu below).
	View	View the logged data as a graph or single text records.
	Print	Send a tabular ASCII report to the device connected to the COM port (see Data Log Print on the next page). Note: only available on transmitters with an RS232 or RS485 interface. The data log must not be empty, and the COM protocol must be set to ASCII. Otherwise, the transmitter will display an exception message.

Figure 76. Data Log Menu

Data Log Setup Menu

Settings on the Data Log Setup page select one of the 12 discrete sampling intervals listed in Table 4, and control starting, stopping and clearing of the data-log.

...DataLog>Setup	Item	Select to ...
<div style="border: 1px solid black; padding: 5px;"> ▶Control=ON Sample= 1 mins Sample/Day=1440 Max_Days= 11 </div>	Control	Turn data logging on or off, or clear stored data.
	Sample Sample/Day Max_Days	Set the sampling interval to one of the 12 values listed in Table 4. Changing one automatically changes the other two. Warning: changing the sampling interval will clear the data-log.

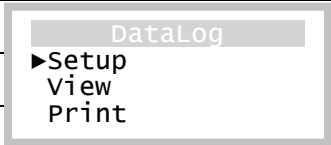
Figure 77. Data Log Setup Menu

Data Log View Menu

Data is presented as a gas concentration reading at a specific date and time and may be viewed collectively as points on a graph (Graph), or individually as a single text record (Single). In Graph view, readings are presented sequentially in time when scrolling the up and down keys. In Single view, both the date and time may be scrolled to provide a pseudo random-access method. Since the two views are connected, it is possible to navigate directly to the date and time of interest using the Single view, and then switch to the Graph view to see more readings around a particular time. Conversely, the view can be switched from Graph to Single to view readings taken around the same time on different days.

...DataLog>View	Item	Select to ...
<div style="border: 1px solid black; padding: 5px;"> View ▶Graph Single </div>	Graph	View multiple points of data as a graph (sequential selection).
	Single	View single records (pseudo random-access selection)

Figure 78. Data Log View Menu

Samples reported are assumed to be in units of PPM, PPB, or %, as determined by the gas concentration units appearing on the Main Display. Sample values outside of printing limits are forced to the following values.

Samples ...	Forced to...
Less than -999	-999
Greater than 9999	9999

Readings in both views are displayed in the same units and decimal precision as those on the Main Display, and the date format is consistent ⁸ with the format selected in the (see pg 77). Both views also display special codes to indicate samples were unavailable. The table below summarizes the special codes.

⁸ Dates presented in the Graph view are shortened to just the month and date, the year is not presented.

Table 5. Data Log Special Codes

<i>Special Code</i>	<i>Description</i>
----	Sample unavailable (transmitter powered off, or sample not yet recorded)
FFFF	Trouble alarm active at time of sample
TEST	Auto-test active at time of sample (if Log_Data=NO, see Auto-test Setup Options Menu)
****	Data is corrupted, or unreliable

Data Log Graph View

The Graph view plots a sample as a vertical line, the height of which corresponds to the gas reading as a percentage of the sensor's range (ie, height = 100*reading/range). Samples are plotted from left (oldest) to right (newest). On entry, a vertical cursor appears over the most recent sample (or sample of interest), and the corresponding date, time, and gas reading or special code (see above) are displayed on the lower line. These values are updated as the cursor is moved left and right by pressing the up and down keys. Note: the gas reading on the lower line is in the same units that appear in the Main Display and Sensor menus.

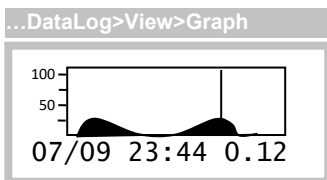

Figure 79. Data Log Graph View

New data is not plotted while viewing the page. Pressing the **Enter** key presents the Data Log Menu shown below, pressing the **Esc** key returns to the previous menu.

Data Log Graph View Menu

The Data Log Graph View Menu is appears by pressing the **Enter** key while viewing the Data Log Graph View (above).

<i>...DataLog>View >Graph ,Enter</i>	<i>Item</i>	<i>Select to ...</i>
	Single	View single records (pseudo random-access selection) starting at the cursor position.
	Print	Send a tabular ASCII report to the device connected to the COM port (see Data Log Print on the next page). Note: only available on transmitters with an RS232 or RS485 interface. The data log must not be empty, and the COM protocol must be set to ASCII. Otherwise, the transmitter will display an exception message.

Figure 80. Data Log Graph View Menu

Data Log Single View

The Data Log Single View Menu allows scrolling to an exact date and time for viewing a single sample. Selecting Graph then presents the Graph view at the selected date and time.

...DataLog>View>Single	Item	Select to ...
▶Date= 07/09/14 Time= 23:44 Conc= 0.12 Graph	Date	Scroll to a specific sample date.
	Time	Scroll to a specific sample time.
	Conc	View the gas reading when sample was recorded (not selectable).
	Graph	View the Graph at the specified date and time.

Figure 81. Data Log Single View Menu

Data Log Print Menus, Methods, and Settings

For transmitters with an optional RS232/RS485 interface, a data log report may be sent to a serial printer, or “captured” to a file using a terminal emulation program. Many terminal emulation programs exist for both Microsoft Windows® and non-Windows platforms.

The report consists of a series of lines, each containing a date and time, followed by up to 30 gas readings. All fields on the line are separated by a TAB character (ASCII 9), which serves to keep the fields aligned in columns. This format is suitable for most Epson protocol printers and for import into most spreadsheet programs after capture. The date and time apply to the first gas reading on the line following the time. Readings appearing in subsequent columns to the right were recorded at the programmed sampling interval after the first reading. The format of the gas readings appear as described in Data Log View Menu on page 60. A report example is shown below.

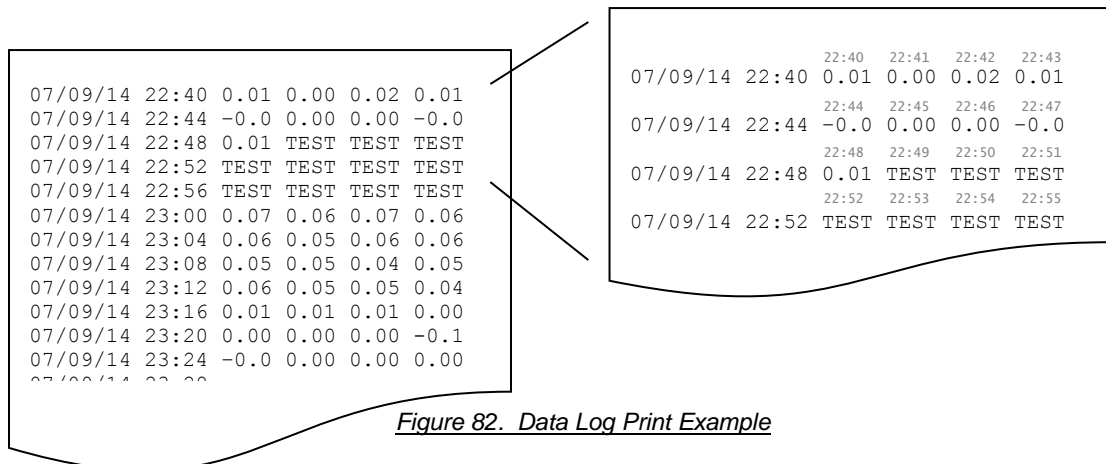

Figure 82. Data Log Print Example

In the example above, the first sample occurred at 22:40. The next sample to the right occurred at 22:41, followed by the next at 22:42, and so on. This pattern is repeated to the end of the line, and then repeats on the line below, and so on.

Data Log Print Menu

The Data Log Print Menu appears by selecting Print from the Data Log Menu (pg 59). The data log must not be empty, and the communication protocol must be set to ASCII before entry (see 4.11 COM Menus on pg 66), or an exception message will be displayed. The transmitter’s real time clock should also be set to the correct date and time.

...DataLog >Print	Item	Select to ...
<pre> ▶First=07/09/14 Days= 1 of 2 Start Format </pre>	First	Set the first date to print in the report. Scrolling this date automatically updates the Days field.
	Days	Set the number of days of data to include in the report.
	Start	Send the report to the device connected to the transmitter’s COM port.
	Format	Configure the report format for the connected device.

Figure 83. Data Log Print Menu

To send the report, set the start date (First) and number of days to print (Days), and select Start. The line will blink Printing until the report is done. The report always begins at 00:00 on the start date, and continues for the number of days specified. If no data has yet been logged, the report will show four dashes (---) in place of samples.

Data Log Print Format Menu

The Data Log Print Format Menu appears by selecting Format from the Data Log Print Menu (above) and is used to control the appearance of the report, and the interaction of the transmitter with the device.

...DataLog >Print>Format	Item	Select to ...
<pre> ▶width= 4 data Eol= CR Delay= 0 ms </pre>	Width	Change the number of data samples (gas readings) printed on each line.
	Eol	Toggle the ASCII control code(s) transmitted at the end of each line from CR to CR/LF (more on this below).
	Delay	Add up to a 10 second delay at the end of each line.

Figure 84. Data Log Print Format Menu

The transmitter adds a CR (ASCII 13) or CR/LF (ASCII 13 and 10) at the end of each line. If the lines of the report appear to be printing over each other, choose the CR/LF option. If the lines appear to be double spaced, choose the CR option.

The number of sample data samples (gas readings) appearing across the page is programmable from 1 to 30. This is designed to allow reports to fit on small thermal printers, and on conventional sized printers. A wider report takes less time to print because the date and time fields are printed less frequently.

A delay of up to 10 seconds can be added after each line is transmitted to help prevent buffer overflows on printers without XON/XOFF protocol. This is sometimes required to allow slow printers enough time to perform carriage return. If characters appear to be missing, increase the setting.

Flow Control

The transmitter uses XON/XOFF flow control while sending a report. That is, once the data stream has begun, it will continue until the XOFF character (19) is received. After sitting idle, the report stream will begin again upon reception of the XON character (17).

An RS232 connection can support full duplex communication and is perfectly suited for XON/XOFF flow control. However, an RS485 connection is only half duplex. It cannot receive while it is transmitting and might miss the XOFF character, resulting in a buffer overflow at the receiving device.

A receiving device will send the XOFF character when its buffer is nearly full. Some older dot-matrix printers will send an XOFF because they have a small receive buffers and cannot process characters while the head is returning to start a new line. By comparison, most computers have comparatively large buffers and can easily accept the report stream without sending an XOFF, so an RS485 connection may work in those cases.

The transmitter features an additional method to help avoid losing data due to buffer overflow problems on receiving devices that lack XON/XOFF capability (or have the capability but are using an RS485 connection). A programmable time delay of up to 10s may be inserted at the end of each report line. This permits the receiver time to process more characters in its buffer and avoid an overflow. However, this may be a method of trial and error until the proper delay setting is determined so that no characters are missing from the report.

4.10 I/O Menus, Methods and Settings

I/O Menu

The I/O menu is shown below and appears by selecting I/O from the Main Menu on pg 38.

Menu>Setup>I/O	Item	Select to ...
	4-20mA	Configure and adjust the 4-20mA output.
	COM	Configure the RS232/RS485 serial interface (option).
	Relays	Configure the three transmitter relays (option).

Figure 85. I/O Menu

4-20mA Output Menus and Methods

The transmitter sources (or sinks) a 4-20mA current that is proportional to the gas reading on the Main Display (see Main Reading on pg 35) . The current is normally 4 mA at zero and 20mA at the programmed range of the sensor (see Range in Sensor Settings Menu on pg 39). Since the Main Reading is blanked below zero, the output should never go below 4mA in the course of normal operation. In the event of gas flooding, the current and *may* go as high as 25mA (125% Range).

Figure 86. Graph of 4-20mA Output

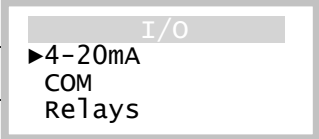
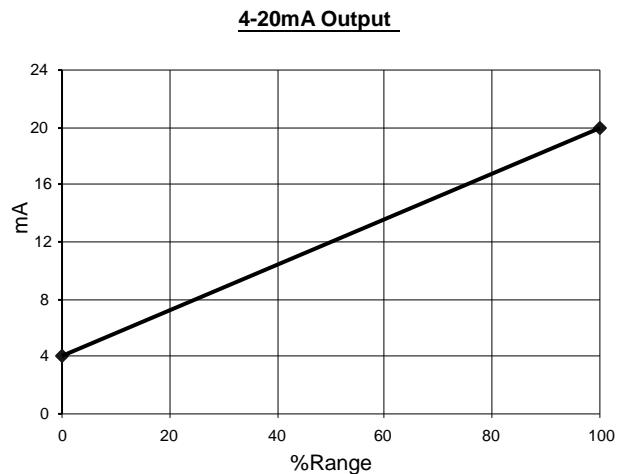

4-20mA Menu

During alarm inhibit and Auto-test, the 4-20mA output is fixed at 4.0mA (17.4mA for oxygen sensors) to prevent false alarms at the receiver. The output is forced to 3.6mA to signal a Trouble alarm to the receiver. These are the default values, which may be changed in the 4-20mA Menu, below.

.../O>4-20mA	Item	Select to ...
▶Autotst mA= 4.0 Inhibit mA= 4.0 Trouble mA= 3.6 Adjust	Autotst mA	Set the fixed output level during Auto-test (4.0 to 22.0 mA). This is normally 4.0mA to prevent alarms at the receiver.
	Inhibit mA	Set the output level to indicate alarms are not enabled (4 to 22 mA). This is normally 4.0mA to prevent alarms at the receiver.
	Trouble mA	Set the output level to indicate the Trouble alarm (3.5 to 3.8 mA). Note: 3.5mA not allowed on 2-wire 4-20mA connection.
	Adjust	Adjust the 4mA and 20mA levels, or force the output for testing.

Figure 87. 4-20mA Menu

4-20mA Adjust Menu

These methods permit adjustment of the 4-20mA output and provide a way to force it to a fixed value to test receiver alarms. They do not affect the computed gas concentration reading.

...4-20mA > Adjust	Item	Select to ...
▶Adjust 4mA Adjust 20mA Force= 4.0mA	Adjust 4mA	Adjust the 4mA analog output level.
	Adjust 20mA	Adjust the 20mA analog output level.
	Force	Force the 4-20mA output to a fixed level between 3.5 and 22.0 mA. Displays the real time value when not selected.

Figure 88. 4-20mA control page

4-20mA Adjustment

Loop adjustment consists of adjusting the 4 and 20 mA levels (order does not matter) by scrolling the corresponding DAC value. This may be accomplished by reading a calibrated current meter connected in series with the transmitter's 4-20mA output, reading a calibrated volt meter across a precision load resistor in series with the transmitter's 4-20mA output, or reading the display of a calibrated, current loop receiver⁹.

Warning: Disable current loop receiver alarms before proceeding.

Adjust 4mA Menu

...4-20mA>Adjust>Adjust 4mA	Item	Select to ...
Adjust 4mA Monitor the ... ▶DAC Count=412	DAC Count	Scroll the DAC (digital-to-analog converter) count up to increase or down to decrease the analog output to 4.00mA. Note The displayed value is "as left" by the previous adjustment.

Figure 89. Adjust 4mA Menu

⁹ When using a current loop receiver, make certain the reading is not limited to 20mA by hardware or programming. If so, adjust the reading first to 19.5mA, then slowly increase it to 20.0mA.

...4-20mA> Adjust> Adjust 4mA	Item	Select to ...
	DAC Count	Scroll the DAC (digital-to-analog converter) count up to increase or down to decrease the analog output to 20.0mA. Note The displayed value is “as left” by the previous adjustment. When selected, however, the DAC count changes to the factory calibrated value of 20.0mA. This is to help prevent adjustment errors caused by 4-20mA receivers that limit readings to 20mA.

Figure 90. Adjust 20mA Menu

4.11 COM Menus and Settings

The transmitter supports ASCII, HART, and Modbus communications, which are configured through the COM Menu below.

COM Menu

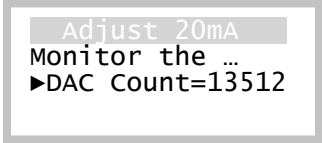
The is COM Menu used to configure the protocol and connection settings of the serial COM interface, and varies slightly, depending on the factory configured protocol.



Menu>Setup>I/O>COM	Item	Select to ...
	Setup	Configure the connection settings (only selection when Protocol is None).
	Print	Print the data log (appears only when the Protocol is ASCII, see Data Log Print Menu on pg 63). Note that the transmitter must have an RS232 or RS485 interface.
	HART	Configure the HART protocol settings (appears only when Protocol is HART). Note that the transmitter must have a HART FSK modem interface, and be ordered with the HART FSK stack option.
	Modbus	Configure the Modbus protocol settings (appears only when Protocol is Modbus). Note that the transmitter must have an RS232 or RS485 interface, and be ordered with the optional Modbus protocol stack option.
		

Figure 91. COM Menu

COM Setup Menu

The COM Setup Menu is used to select the protocol and configure the transmitter’s connection settings.

Item	Select to ...
<pre> ...COM>Setup ▶Protocol=None </pre>	<p>Change the slave protocol.</p> <ul style="list-style-type: none"> • ASCII (default) • Modbus (option) • HART (option) • None <p>Protocol selection is performed at the factory and may not be changed. Settings for the ASCII and Modbus protocols may be changed, but are restricted for the HART protocol.</p>
<pre> ...COM>Setup ▶Protocol=ASCII Interface=RS232 Baud Rate=9600 Settings= N,8,1 </pre>	
<pre> ...COM>Setup ▶Protocol=HART Interface=FSK Baud Rate=1200 Settings= 0,8,1 </pre>	
<pre> ...COM>Setup ▶Protocol=Modbus Interface=RS485 Baud Rate=9600 Settings= N,8,1 </pre>	
Interface	<p>Change the physical communication interface that the transmitter will control during transmit and receive functions:</p> <ul style="list-style-type: none"> • RS232 (available for ASCII or Modbus, not for HART) • RS485 (available for ASCII or Modbus, not for HART) • FSK (HART only)
Baud Rate	<p>Change the baud rate of the transmitter’s UART. May be set to: 300, 600,1200, 2400, 4800, 9600, 14.4k, 19.2k, 28.8k, 38.4k, 57.6k, 115.2k, 230.4k, and 460.8k.</p> <p>The value is fixed at 1200 for HART FSK, and defaults to 9600 for Modbus and ASCII.</p>
Settings	<p>Change the parity, number of data bits, and number of stop bits of the transmitter’s UART:</p> <p>N,8,1 ...no parity, 8 data bits, 1 stop bits N,8,2 ...no parity, 8 data bits, 2 stop bits E,8,1 ...even parity, 8 data bits, 1 stop bit O,8,1 ...odd parity, 8 data bits, 1 stop bit</p> <p>The value is fixed at O,8,1 for HART protocol, and defaults to N,8,1 for Modbus and ASCII.</p>

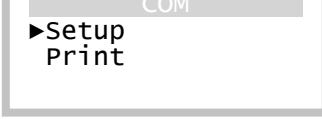
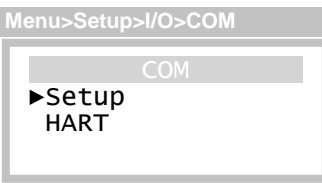
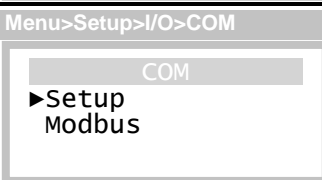
Figure 92. COM Setup Menu

HART

The following applies to transmitters that have the HART FSK modem interface and HART FSK firmware option.

A HART “point-to-point” connection permits simultaneous digital and analog communication between one or two masters and one slave device. A HART multi-drop connection permits one or two masters and up to 15 devices to communicate digitally but prohibits analog communication by requiring each slave device to fix its output at its lowest level (4mA). For more information, see the HART Transmitter connection examples in Figure 29 on page 29, or consult the HART Foundation (www.hartcomm.org) for details on how to connect a HART transmitter.

HART FSK devices communicate digitally by imposing a 1mA pk-pk waveform on the 4-20mA output using a technique called Frequency-Shift-Keying. FSK interprets binary 0 as one cycle at 2200 Hz, and binary 1 as one cycle at 1200 Hz. Since each cycle increases the output by ½ mA and then decreases it by ½ mA, it FSK does not affect the average analog level. This allows a HART FSK device to use both analog and digital communication on a single connection.

HART Menu

The HART Menu appears by selecting HART from the COM Menu (pg 66).

...COM>HART	Item	Select to ...
<div style="border: 1px solid black; padding: 5px;"> HART Tag=GAS XMTR ►Identification Operation </div>	Tag	This setting is read-only and can be used as a unique identifier for communicating to the transmitter. The setting is read only at the operator interface, but may be modified using HART network management commands. This field is assigned by the HART master.
	Identification	View the HART Identification Menu
	Operation	View the HART Operation Menu

Figure 93. HART Menu

...COM>HART>Identification	Item	Description
<div style="border: 1px solid black; padding: 5px;"> Device=9f/7f/02 ►Poll Addr=0 Dev Id=8275 </div>	Device	This setting is read-only and displays device information used in long-frame address commands, and by devices capable of utilizing the transmitter’s DDL (device description language) file. The format of the information is, MFG_ID/DEV/REV. The MFG_ID is 9f, and identifies Analytical Technology, Inc as the manufacturer. DEV is 7f, and identifies the device as a D12 transmitter. REV is the revision level of the transmitter, currently set at 2 (may increment in the future).
	Poll Addr	Use this to change the polling address of the transmitter. The default value is 0, which allows the transmitter to communicate digitally, while preserving the function of the 4-20mA output. The value may be set from 1 to 15, which fixes the output at 4mA, and disables analog signaling.
	Dev Id	This setting is used to form a unique identifier in the HART long frame address. This value is set at the factory, and appears on a label attached to the transmitter. Changing this setting is not recommended.

Figure 94. Hart Identification Menu

...COM >HART>Operation	Item	Description
<div style="border: 1px solid black; padding: 5px;"> ►Mode= Not-Fixed Fixed mA= 0.0 Resp Preamb= 5 Find-Me </div>	Loop	This setting specifies the analog operating mode of the 4-20mA output. When the HART polling address is 0, the value is Not-Fixed and analog signaling functions normally. When the address is set to 1 or higher, the value is Fixed and the analog output is fixed at 4mA. The ability to alter this behavior is reserved for future use, and changing this setting is not recommended.

	Fixed mA	This setting provides direct access the associated HART network management setting. The value is adjustable only when the Loop setting is FIXED, and may be adjusted between 3.5 (4mA on 2-wire power) and 22 mA.
	Resp Preamb	This setting provides direct access to the associated HART network management setting, which determines the number of preamble characters (FF hex) transmitted at the beginning of each message. The default value is 5, and may be set from 3 to 20. Changing this setting is not recommended.
	Find-Me	This method places the transmitter into a mode that causes the transmitter to respond to the Find Device command. This is used by personnel identify transmitter in the field. The method is describe below.

HART Find Device

Selecting Find-Me presents a special page that remains until the master device issues a “Find Device” command to the transmitter, at which point, line 1 of the display changes from “FIND ME ARMED” to “DEVICE FOUND”.

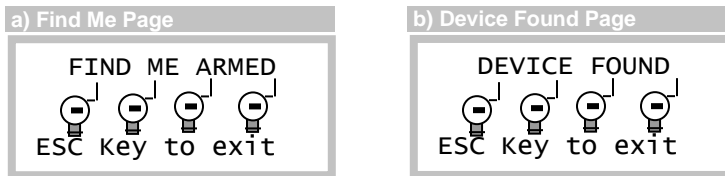

Figure 95. Hart Find-Device Display

Modbus

The following applies to transmitters that have an RS232 or RS485 COM interface and Modbus firmware options. The RS232 and RS485 option is NOT INTENDED for use in Hazardous Locations.

Modbus is a master/slave protocol that supports a single master, and up to 247 slave devices on a common bus. The RS485 interface physically limits this number to 32 (1 master, 31 slaves), and RS232 restricts communication to a master and a single slave. Note that the 4-20mA output is fully functional even when using the transmitter’s Modbus interface.

Modbus Menu

The Modbus Menu appears by selecting Modbus from the COM Menu (pg 66).

Menu>Setup>I/O>COM>Modbus	Item	Description
	Poll Addr	This setting controls the address to which the transmitter responds to queries from the host (1-247, default =1).
	Timeout	This setting belongs to the data-link layer of the protocol and defines the number of character bits used to frame Modbus RTU messages. The protocol specifies the silent interval as 3.5 characters, which corresponds to 35 bit-times at 10 bits per character. This setting is reserved for future use and changing it is not recommended.

Figure 96. Modbus Menu

More information about configuring the Modbus connection can be found in the table below.

<i>More Information...</i>	<i>Where to find...</i>
Connect to a master using an RS485 multi-drop connection.	Figure 21 on page 23
Connect to a master using an RS232 connection.	Figure 21 on page 23
Select Modbus protocol and configure the communication settings.	COM Setup Menu on page 678
Modbus register map	The transmitter’s Modbus interface is robust and maintained in a separate document. Download or request a copy of, “D12/F12 Series Modbus Interface Manual”.

Relay Operation, Menus, and Settings

The following applies to F12 transmitters ordered with optional 3 SPST relays that are NOT INTENDED for Hazardous Locations.

The F12 Alarm Relay option provides three SPST mechanical relays on the Power Supply board. The relays are rated for 5 amps, non-inductive loads at 250VAC, and are suitable for switching small loads, such as horns and warning lights, but should not be used to switch motors or other high current, inductive loads.

Each relay coil may be assigned to one of the four alarms and operate as normally energized (Norm=1, also called “fail-safe”), or normally de-energized (Norm=0). Selecting normally energized (1) allows the relay to indicate an alarm, or a power failure. This selection is made in the Relay Setup Menu on page 72.

The table below details the contact states for the two selections in the no-alarm, alarm, and power fail conditions.

Table 6. Relay Coil “Norm” Setting

	<i>No-Alarm</i>	<i>Alarm</i>	<i>Power Failure</i>
0 (normally de-energized)			
Coil	De-energized	Energized	De-energized
Closed Contacts	C-NC	C-NO	C-NC
1 (normally energized, “fail-safe”)			
Coil	Energized	De-energized	De-energized
Closed Contacts	C-NO	C-NC	C-NC

Figure 97 illustrates the alarm and relay operation.

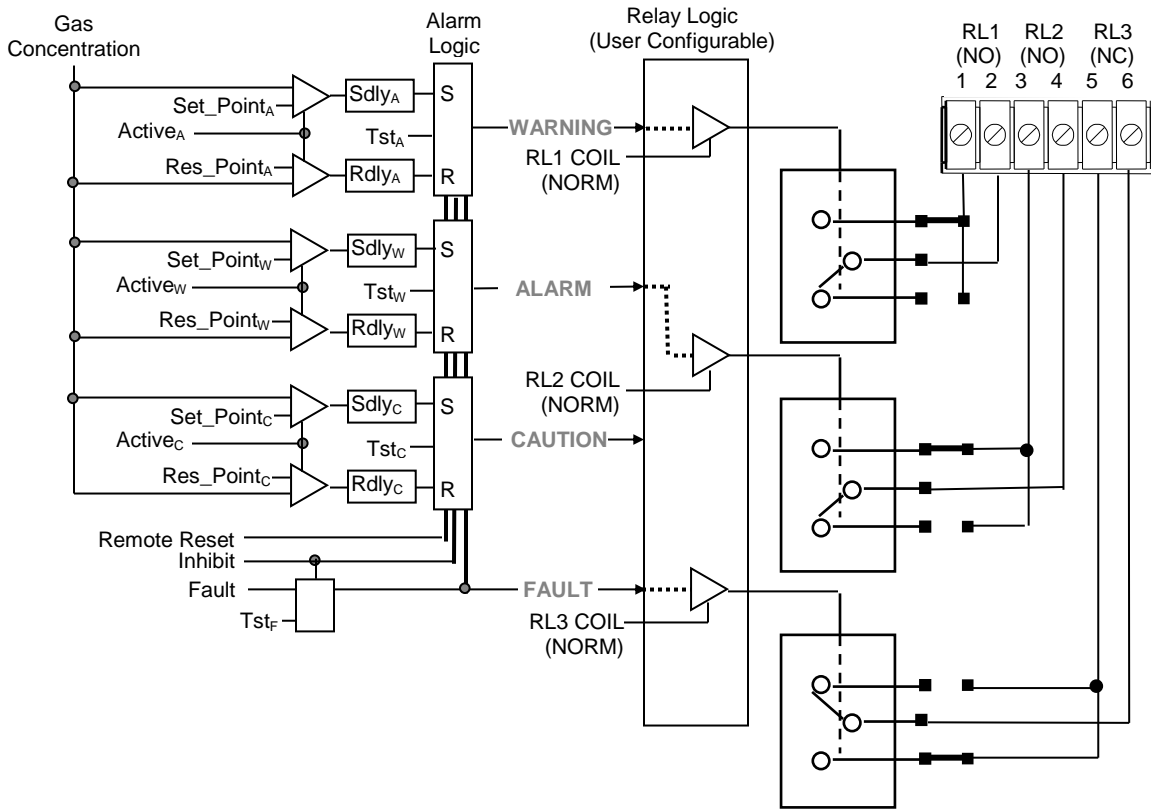

Figure 97 Alarm Relay Diagram

Relays Menu

The Relays Menu appears by selecting Relays from the **I/O Menu** (see pg 64) .

Menu>Setup>I/O>Relays	Item	Select to ...
<div style="border: 1px solid black; padding: 5px; margin-bottom: 5px;"> <p style="text-align: center;">Relays</p> <p>▶Active= No Setup</p> </div>	Active	Permanently enable or disable operation of .the relays.
	Setup	Assign each relay to an alarm and select the normal state of its coil.

Figure 98. Relays Menu

Relay Setup Menu

The Relay Setup Menu appears by selecting Setup from the Relays Menu above.

...Relays>Setup	Item	Select to ...
	Coil	Change the alarm assigned to the relay coil. Selections are ALARM, WARNING, CAUTION, or TROUBLE.
	Norm	Change the normal (no-alarm) state of the coil to: normally de-energized normally energized ("fail-safe") See Table 6 on page 70.

Figure 99. Relay Setup Menu

4.11 Panel Menus, Methods, and Settings

Panel Menu

Menu >Setup >I/O>Panel	Item	Select to ...
	Display	Adjust the display contrast or when the backlight comes on. Note: backlight operates only when powered in 3 or 4 wire mode.
	Security	Lock or unlock the transmitter panel, or change the password.

Figure 100. Panel Menu

Display Menu

The transmitter features a backlighted, 96w x 32h graphics LCD. The Display menu is used to control the display contrast and manage the backlight.

...Panel>Display	Item	Select to ...
	Contrast	Adjust the LCD contrast. Scroll the setting up to increase contrast (darker text), or down to decrease it (lighter text). The default value is 50%, and is adjustable between 0 and 100%.
	Light*	Control when the LCD backlight is turned on and off* : Manual On when any key is pressed Off when no key pressed for 5 minutes Auto On when any key is pressed or alarm is active Off when no key pressed for 5 minutes, and no alarms active Never On

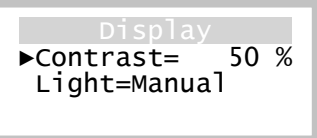
		Off permanently Always On On permanently (not recommended)
--	--	----------------------------------------------------------------------

Figure 101. Display Menu

Security Menu

The transmitter prevents changes to the transmitter configuration through the front panel when security is active. Settings may be read, but not modified, and methods will not execute, including verifications during Sensor Review (see pg 33). To do so, security must be disabled, either permanently or temporarily, by entering the correct 4-digit code. Panel security status is indicated on the 4.3 Main Display as shown on page 35.

...Panel>Security	Item	Select to ...
<div style="border: 1px solid gray; padding: 5px; margin-bottom: 5px;"> Security ▶Active= No Change Code </div>	Active	Activate or deactivate panel security. You must enter the panel code in either case. See Figure 103. Activating Security and Figure 104. Deactivating Security
	Change Code	Change the panel code.

Figure 102. Security Menu

Activating Security

The following display sequence appears when attempting to activate panel security.

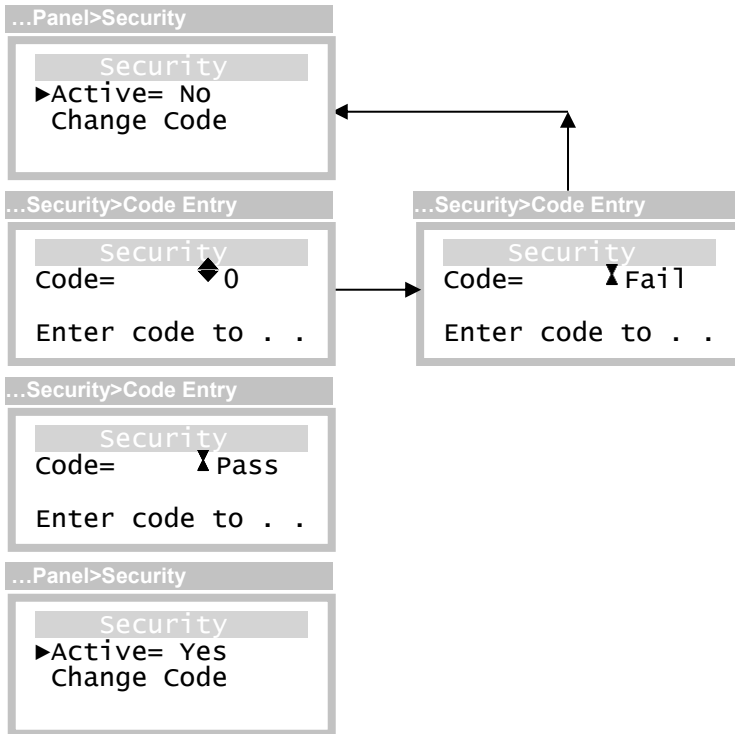
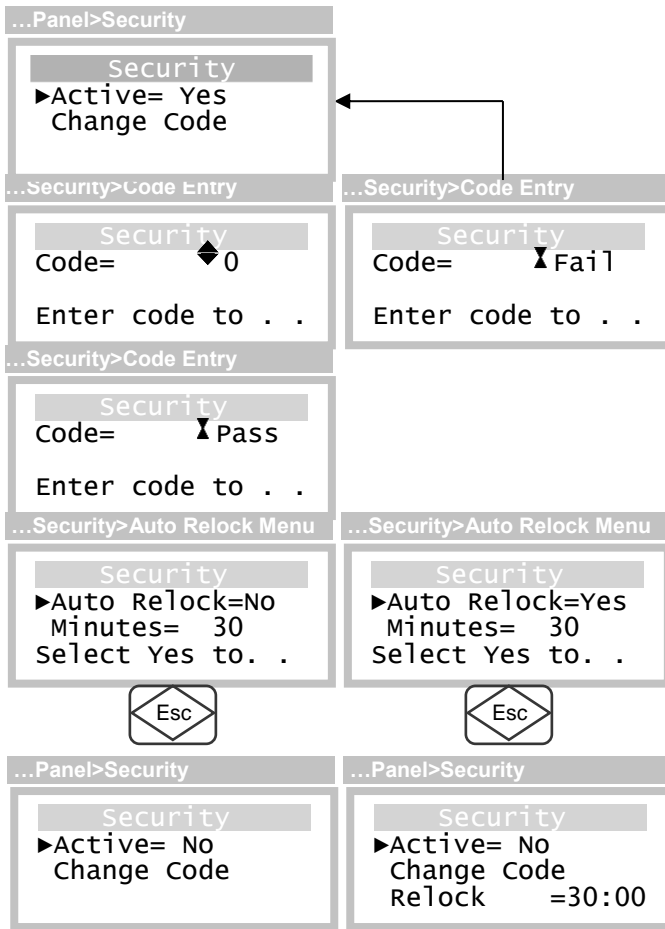

Figure 103. Activating Security

Deactivating Security

The following display sequence appears when attempting to deactivate panel security. Note the option for automatically relocking the panel after a timed period.



The automatic relock time defaults to 30 minutes, but may be extended up to 60 minutes.

Press the Esc key to exit the Relock display.

The panel re-lock timer is displayed on line 4, but is fixed to prevent relocking while viewing this display. You may select Relock to return to the Auto Relock Menu to extend the period, if necessary.

Figure 104. Deactivating Security

Changing the Security Code

The security code is changed by selecting Change Code from the Security Menu above.

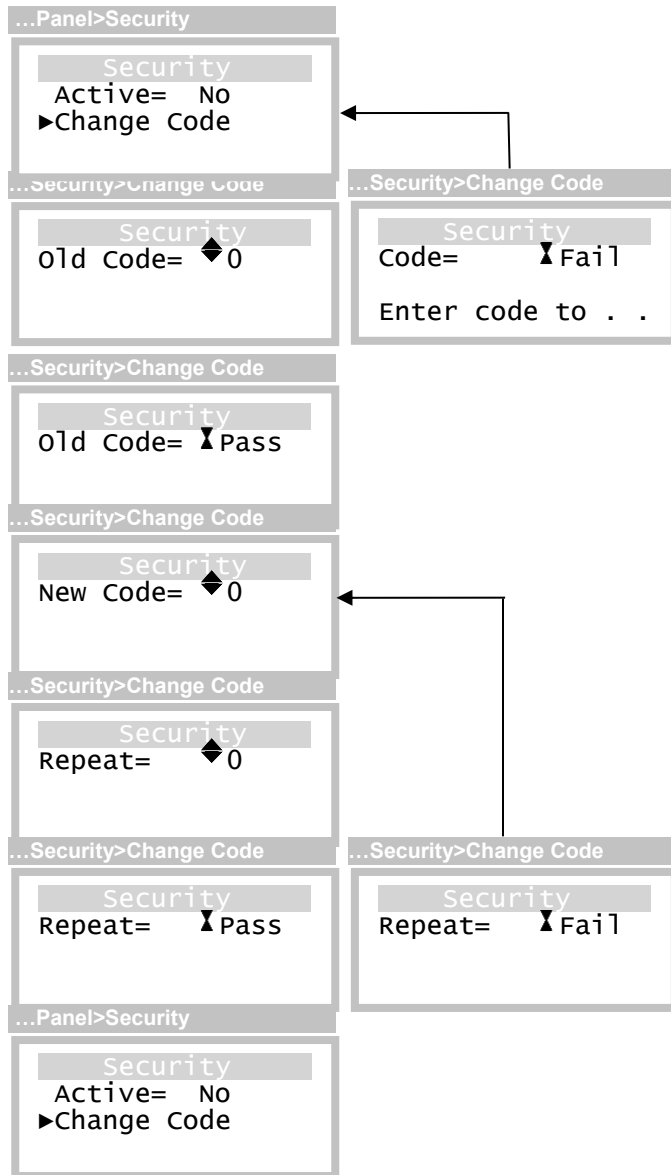

Figure 105. Changing the Security Code

4.12 System Menu

>Menu >Setup >System	Item	Select to ...
<div style="border: 1px solid gray; padding: 5px;"> System ▶Clock Site Reset Version </div>	Clock	Set or update the transmitter’s real-time-clock.
	Reset	Restart the transmitter or change all user settings to default values.
	Version	Display transmitter and sensor version information.
	Site	Change the site name displayed during startup review.

Figure 106. System Menu

Clock Menu

The Clock Menu is used to set the transmitter’s real-time clock, which is recorded during sensor calibration and data logging, and is used to trigger Auto-test starts

>Menu >Setup >System >Clock	Item	Select to ...
<div style="border: 1px solid gray; padding: 5px;"> ▶Tuesday 09/14/2014 MM/DD/YYYY 14:00 </div>	Line 1	Change the day of the week: Monday, Tuesday, Wednesday, Thursday, Friday, Saturday, and Sunday
	Line 2	Configure the month, date, and year, in the format specified by the Format setting (below). Built-in support for leap year. Note: you may select and adjust the year separately.
	Line 3	Change the date format: MM/DD/YYYY, example: 09/14/2014 DDMMM/YYYY, example: 09Sep/2014
	Line 4	Change the time of day (24-hour format, 00:00 to 23:59)

Figure 107. Clock Menu

Reset Menu

>Menu >Setup >System	Item	Select to ...
<div style="border: 1px solid gray; padding: 5px;"> ▶Restart UserMem </div>	Restart	Restart the transmitter without cycling power.
	UserMem	Reset all user settings to default values. NOTE: this method is provided to recover from a corrupted user memory. It does not affect calibration of the sensor or transmitter analog inputs or outputs. After running this method, you will be required to manually restore all of the transmitter alarm, data logger, i/o (communications, relays, and 4-20mA), panel (display and security), settings, as well as the transmitter’s real-time clock.

Figure 108. Reset Menu

Version Menu

The Version Menu appears by selecting Version from the System Menu above and lists the major components of the transmitter as menu entries.

>Menu>Setup>System>Version	Item	Select to ...
<div style="border: 1px solid gray; padding: 5px;"> Settings ▶Xmtr SIB Sensor GasGen </div>	Xmtr	View the transmitter version information.
	Sensor	View the sensor version information.
	GasGen	View the gas generator version information.
...Version>Xmtr	SIB	View the SIB (board) version information.
<div style="border: 1px solid gray; padding: 5px;"> Xmtr D12Ex-ver-id Hw=xxxx/Sw=xxxx </div>	g/n	Gas number – identifies a gas species
...Version>Sensor	m/n	Model number – identifies a series model type
<div style="border: 1px solid gray; padding: 5px;"> Sensor H10-p/n-id Hw=xxxx/Sw=xxxx </div>	p/n	Part number – identifies a specific assembly
...Version>GasGen	id	Identity – uniquely identifies a CPU board assembly*
<div style="border: 1px solid gray; padding: 5px;"> GasGen C18-g/n-id Hw=xxxx/Sw=xxxx </div>	ver	Version number – indexes a specific assembly (shorter text)
...Version>SIB	Hw	Hardware revision – revision level of the electronics
<div style="border: 1px solid gray; padding: 5px;"> SIB SIB-m/n-ver-id Hw=xxxx/Sw=xxxx </div>	Sw	Software revision – revision level of the software
	* Id numbers displayed here are used to identify board level components and are not intended to identify the complete device. These numbers will not match serial numbers printed on labels physically attached to the device.	

Figure 109. Version Menu

Part 5 – Maintenance

The F12/D is virtually maintenance free. Other than the consumable sensor and auto-test generator, the battery backup for the real time clock is the only other user replaceable part.

Real Time Clock Battery Replacement

WARNING:

Disconnect power, and move unit to a non-hazardous area before servicing.

WARNING:

Replace with only Panasonic CR2032 battery

1. Loosen the four screws securing the front enclosure (1)
2. Remove the front enclosure (1) from the rear enclosure (2), by squeezing the hinge pin (3)

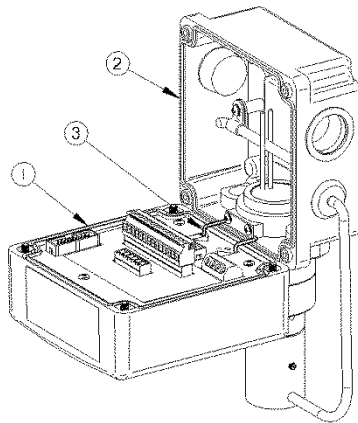

3. Remove the Internal Shield by removing the three screws (4)

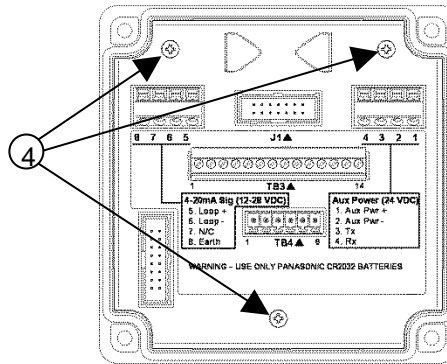

4. Remove the Terminal PCB by pulling straight up, to expose the CPU PCB (5).

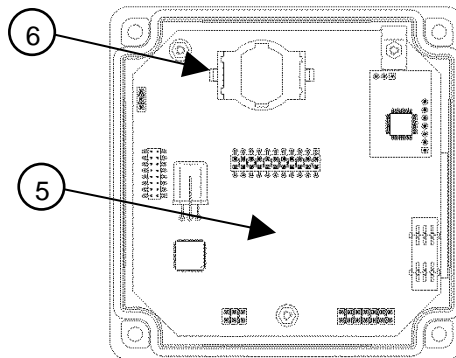

5. Remove the Battery (6), and replace with same kind.
6. Reverse steps 4 through 1 to re-assemble the unit.
7. After powering up the unit, set the data and time.
 - a. Note: You will be forced to disable Auto-test on startup until the clock has been set.

Part 6 – Spare Parts

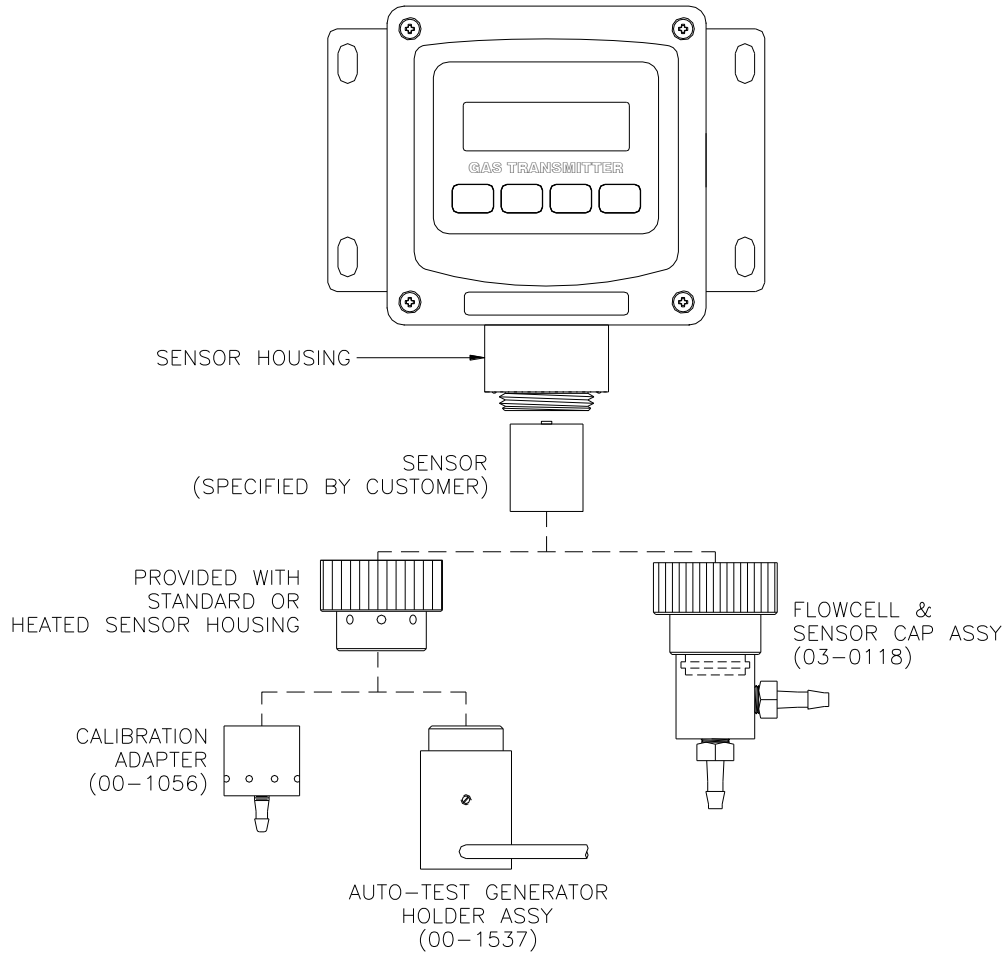

Figure 110 - Exploded View

Part No.	Description
03-0477	F12/D Transmitter Front Lid Assembly
03-0479	F12/D Transmitter Front Lid Assembly w/ HART
00-1699	F12 Sensor Holder Assembly (heated)
00-1700	F12 Sensor Holder Assembly
03-0332	Standard Sensor Cap
00-1698	Auto-Test Generator Holder Assembly
01-0413	Power Supply / Relay Board Assy, AC Version
01-0418	Power Supply / Relay Board Assy, DC Version
31-0192	Ribbon Cable, P/S to Front Lid, 20 conductor
29-0013	Battery
00-1056	Calibration adapter
03-0118	Flowcell & Solid Sensor Cap Assy
00-1702	6' Sensor Housing Assembly

Table 7. H10 sensor modules

Part No.	Description
00-1000	Bromine, 0-1/5 PPM (2 PPM Standard)
00-1001	Bromine, 0-5/200 (20 PPM Standard)
00-1002	Chlorine, 0-1/5 PPM (2 PPM Standard)
00-1003	Chlorine, 0-5/200 (20 PPM Standard)
00-1004	Chlorine dioxide, 0-1/5 PPM (2 PPM Standard)
00-1005	Chlorine dioxide, 0-5/200 (20 PPM Standard)
00-1006	Fluorine, 0-1/5 PPM (2 PPM Standard)
00-1007	Fluorine, 0-5/200 (20 PPM Standard)
00-1008	Ozone, 0-1/5 PPM (2 PPM Standard)
00-1009	Ozone, 0-5/200 PPM (20 PPM Standard)
00-1010	Ammonia, 0-50/500 PPM (200 PPM Standard)
00-1011	Ammonia, 0-500/2000 PPM (1000 PPM Standard)
00-1012	Carbon monoxide, 0-50/1000 PPM (200 PPM Standard)
00-1013	Hydrogen, 0-1/10% (4% Standard)
00-1014	Oxygen, 0-5/25% (25% Standard)
00-1015	Phosgene, 0-1/5 PPM (2 PPM Standard)
00-1016	Phosgene, 0-5/100 PPM (100 PPM Standard)
00-1017	Hydrogen chloride, 0-10/200 PPM (20 PPM Standard)
00-1018	Hydrogen cyanide, 0-10/200 PPM (20 PPM Standard)
00-1019	Hydrogen fluoride, 0-10/200 PPM (20 PPM Standard)
00-1020	Hydrogen sulfide, 0-10/200 PPM (50 PPM Standard)
00-1021	Nitric oxide, 0-50/500 PPM (200 PPM Standard)
00-1022	Nitrogen dioxide, 0-10/200 PPM (20 PPM Standard)
00-1023	Sulfur dioxide, 0-10/500 PPM (20 PPM Standard)
00-1024	Arsine, 0-500/2000 PPB (1000 PPB Standard)
00-1025	Arsine, 0-10/200 PPM (10 PPM Standard)
00-1026	Diborane, 0-500/2000 PPB (1000 PPB Standard)
00-1027	Diborane, 0-10/200 PPM (10 PPM Standard)
00-1028	Germane, 0-500/2000 PPB (1000 PPB Standard)
00-1029	Germane, 0-10/200 PPM (10 PPM Standard)
00-1030	Hydrogen selenide, 0-500/2000 PPB (1000 PPB Standard)
00-1031	Hydrogen selenide, 0-10/200 PPM (10 PPM Standard)
00-1032	Phosphine, 0-500/2000 PPB (1000 PPB Standard)
00-1033	Phosphine, 0-10/200 PPM (10 PPM Standard)
00-1034	Phosphine, 0-200/2000 PPM (1000 PPM Standard)
00-1035	Silane, 0-10/200 PPM (10 PPM Standard)
00-1036	Iodine, 0-1/5 PPM (2 PPM Standard)
00-1037	Iodine, 0-5/200 PPM (20 PPM Standard)
00-1038	Acid gases, 0-10/200 PPM (20 PPM Standard)
00-1039	Ethylene oxide, 0-20/200 PPM (20 PPM Standard)
00-1040	Formaldehyde, 0-20/200 PPM (20 PPM Standard)
00-1041	Hydrogen, 0-500/2000 PPM (2000 PPM Standard)
00-1042	Hydrogen peroxide, 0-10/100 PPM (20 PPM Standard)
00-1043	Alcohol, 0-50/500 PPM (200 PPM Standard)
00-1044	Alcohol, 0-500/2000 PPM (2000 PPM Standard)

00-1057	Acetylene, 0-50/500 PPM (0-200 PPM Standard)
00-1169	Hydrogen peroxide, 200/2000 PPM (500 PPM Standard)
00-1181	NOx, 50/500 PPM (200 PPM Standard)
00-1285	Silane, 500/2000 PPB (1000 PPB Standard)
00-1349	Formaldehyde, 500/2000 PPM (1000 PPM Standard)
00-1358	Ozone, 200/1000 PPM (1000 PPM Standard)
00-1359	Chlorine dioxide, 200/1000 PPM (1000 PPM Standard)
00-1425	Chlorine dioxide, 1/5 PPM (low Cl2 response)
00-1450	Dimethylamine (DMA), 100/200 PPM (100 PPM Standard)
00-1455	Hydrogen bromide, 10/200 PPM (20 PPM Standard)
00-1469	Hydrogen sulfide, 200/1000 PPM (500 PPM Standard)

Table 8. E18 gas generators

Part No.	Description
00-1538	Chlorine
00-1539	Ammonia
00-1540	Carbon Monoxide
00-1541	Hydrogen Sulfide
00-1542	Sulfur Dioxide

Table 9. Miscellaneous accessories

Part No.	Description
00-1388	H10 Duct Mount Adapter
00-1389	H10 Duct Mount Sensor Holder
46-0003	Sensor Gasket for (00-1389)
03-0414	Duct Mount Cable Assembly
03-0370	Communications Jumper Plug (for RS232/RS485 Options)

PRODUCT WARRANTY

Analytical Technology, Inc. (Manufacturer) warrants to the Customer that if any part(s) of the Manufacturer's products proves to be defective in materials or workmanship within the earlier of 18 months of the date of shipment or 12 months of the date of start-up, such defective parts will be repaired or replaced free of charge. Inspection and repairs to products thought to be defective within the warranty period will be completed at the Manufacturer's facilities in Collegeville, PA. Products on which warranty repairs are required shall be shipped freight prepaid to the Manufacturer. The product(s) will be returned freight prepaid and allowed if it is determined by the manufacturer that the part(s) failed due to defective materials or workmanship.

This warranty does not cover consumable items, batteries, or wear items subject to periodic replacement including lamps and fuses.

Gas sensors, except oxygen sensors, are covered by this warranty, but are subject to inspection for evidence of extended exposure to excessive gas concentrations. Should inspection indicate that sensors have been expended rather than failed prematurely, the warranty shall not apply.

The Manufacturer assumes no liability for consequential damages of any kind, and the buyer by acceptance of this equipment will assume all liability for the consequences of its use or misuse by the Customer, his employees, or others. A defect within the meaning of this warranty is any part of any piece of a Manufacturer's product which shall, when such part is capable of being renewed, repaired, or replaced, operate to condemn such piece of equipment.

This warranty is in lieu of all other warranties (including without limiting the generality of the foregoing warranties of merchantability and fitness for a particular purpose), guarantees, obligations or liabilities expressed or implied by the Manufacturer or its representatives and by statute or rule of law.

This warranty is void if the Manufacturer's product(s) has been subject to misuse or abuse, or has not been operated or stored in accordance with instructions, or if the serial number has been removed.

Analytical Technology, Inc. makes no other warranty expressed or implied except as stated above.

WATER QUALITY MONITORS

Dissolved Oxygen
Free Chlorine
Combined Chlorine
Total Chlorine
Residual Chlorine Dioxide
Potassium Permanganate
Dissolved Ozone
pH/ORP
Conductivity
Hydrogen Peroxide
Peracetic Acid
Dissolved Sulfide
Residual Sulfite
Fluoride
Dissolved Ammonia
Turbidity
Suspended Solids
Sludge Blanket Level

MetriNet Distribution Monitor

GAS DETECTION PRODUCTS

NH ₃	Ammonia
CO	Carbon Monoxide
H ₂	Hydrogen
NO	Nitric Oxide
O ₂	Oxygen
CO	Cl ₂ Phosgene
Br ₂	Bromine
Cl ₂	Chlorine
ClO ₂	Chlorine Dioxide
F ₂	Fluorine
I ₂	Iodine
H _x	Acid Gases
C ₂ H ₄ O	Ethylene Oxide
C ₂ H ₆ O	Alcohol
O ₃	Ozone
CH ₄ Gas)	Methane (Combustible
H ₂ O ₂	Hydrogen Peroxide
HCl	Hydrogen Chloride
HCN	Hydrogen Cyanide
HF	Hydrogen Fluoride
H ₂ S	Hydrogen Sulfide
NO ₂	Nitrogen Dioxide
NO _x	Oxides of Nitrogen
SO ₂	Sulfur Dioxide
H ₂ Se	Hydrogen Selenide
B ₂ H ₆	Diborane
GeH ₄	Germane
AsH ₃	Arsine
PH ₃	Phosphine
SiH ₄	Silane
HCHO	Formaldehyde
C ₂ H ₄ O ₃	Peracetic Acid
DMA	Dimethylamine